

VERSION 14



CABLE MANAGEMENT SOLUTIONS

A PART OF



CABLE TRAY SYSTEMS

COPE® CABLE TRAY SOLUTIONS FOR YOUR INFRASTRUCTURE REQUIREMENTS

Welcome to our new products catalog. This complete catalog is designed for ease of use and to provide the basic information needed to select the proper cable tray system for your needs.

The first section of the catalog provides comprehensive product information, definitions, and technical data needed to select the proper tray. The second section provides industry standards and guidelines for the manufacture and installation of cable tray.

Cope's Swaged Ladder tray uses our patented swaging system of rung attachment. This system of attachment provides a very rigid tray without welding that is easy to handle and install. The flange out design provides the maximum access to your cables, even in narrow or divided cable trays.

Cope's Hat Rung tray provides a flange in alternative for those instances where space is critical. With the flanges turned inward, this tray can be fitted into confined spaces. Slotted rungs provide excellent cable tie down capability.

Cope Trof provides the ultimate in cable support for your small diameter, flexible cable. With 1" ribs located every 2" on center, drooping of cable is virtually eliminated.

Cope's I-BEAM tray provides a heavy duty welded cable tray for clients requiring I-BEAM side rails. It is perfect for long span locations, heavy loads, and will interface with existing "I" Beam configuration trays.



Cope Channel provides an excellent support system for those applications where only a few cables are needed. It can also be used for separation of services in ladder or trof trays.

Cope wire basket provides the superior flexibility and ease of installation required by data-com installations. The exclusive Kwik-Latch system speeds cable tray installation.

Cope Glas™ fiberglass cable tray provides the answer to many adverse environments. Life cycle costs, long span capability and easy field modification make Cope Glas an ideal choice for industrial, chemical, and petrochemical facilities.

Our customer service team is available to assist with questions about application, installation, and availability of our products.

Thank you for considering Cope for your cable tray requirements.

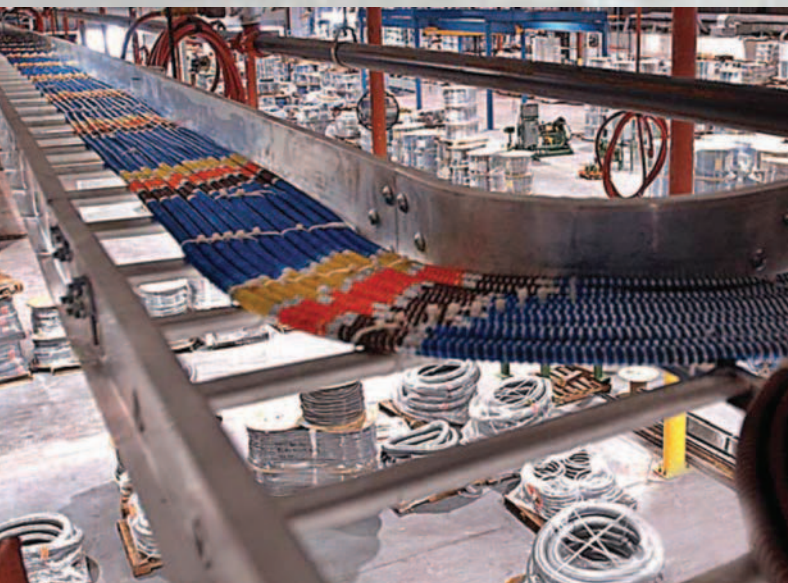

COPE, previously known as T.J. Cope

Thomas Jefferson Cope founded T.J. Cope in Philadelphia, Pennsylvania in 1887. At that time, T.J. Cope's primary business was designing and manufacturing cable installation/pulling equipment for overhead and underground applications.

In 1948, T.J. Cope introduced the first modular Cable Tray System. The tray system was fabricated from sheet metal with the edges turned up forming a trof shape. This type of installation offered a more flexible and economical alternative to the traditional use of conduit.

In 1957, T.J. Cope was purchased by the Rome Cable Corporation, which in turn, was purchased by Alcoa in 1959. The Cyprus Mines Corporation purchased T. J. Cope six years later when the U. S. Justice Department forced Alcoa to divest its holdings of the Rome Cable Company.

T.J. Cope was merged into Allied Tube & Conduit Corporation in 2005. The Cope brand is owned by Allied Tube & Conduit Corporation and is part of the Electrical and Support Division. Allied Tube & Conduit Corporation is a world leading manufacturer of galvanized steel tubing, including electrical conduit; its affiliate, AFC Cable Systems, provides AC/MC cable and flexible conduits; and its other affiliate, Unistrut International Corporation, provides Power-Strut and Unistrut metal framing systems. Allied Tube & Conduit Corporation, a part of Atkore International, serves the electrical, mechanical, and construction markets worldwide.

Headquarters:

Atkore International
16100 S. Lathrop Avenue
Harvey, IL 60426
Tel: 708-339-1610
Fax: 708-339-0615
Toll Free: 800-825-5433







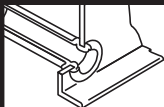

Manufacturing:

Atkore International
11500 Norcom Road
Philadelphia, PA 19154
Tel: 215-961-2570
Fax: 215-961-2580

Atkore International
11539 North Houston Rosslyn Road
Houston, TX 77088
Tel: 281-445-2900
Fax: 281-931-9324



INTRODUCTION/CONTENT

SECTION 1	FEATURES & TECHNICAL DATA	 Cutaway - Cope Swage
SECTION 2	NEMA STANDARD VE-1	
SECTION 3	LADDER	
SECTION 4	HAT	
SECTION 5	TROF	
SECTION 6	HARDWARE	
SECTION 7	I-BEAM	
SECTION 8	CHANNEL	
SECTION 9	GLAS™	
SECTION 10	WIRE BASKET	
SECTION 11	REFERENCE DATA	

Intro
LADDER
HAT
TROF
HARDWARE
I-BEAM
CHANNEL
COPE-GLAS™
WIRE BASKET
Reference

PRODUCT FEATURES

OVERVIEW

SELECTING A COPE® CABLE TRAY SYSTEM

A number of factors must be considered when selecting the proper cable tray system and planning the installation:

- Material and Finish
- Types of Cable Tray
- NEMA Class
- Cavity Size - Load/Depth/Width of Tray
- Length of Straight Sections
- Rung Spacing
- Radius of Fittings
- Cable Tray Support Locations
- Electrical Grounding

CABLE TRAY SYSTEM DRAWING LEGEND

- 1 Straight Section, Ladder (SL)
- 2 Horizontal Elbow, 90°, Ladder Type (9F)
- 3 Horizontal Elbow, 30° (3F), 45° (4F) or 60° (6F)
- 4 Horizontal Cross, Ladder Type (FC)
- 5 Horizontal Tee, Ladder Type (FT)
- 6 Vertical Elbow, Outside, 90° (9O)
- 7 Vertical Elbow, Outside & Inside, 30° (3O, 3I), 45° (4O, 4I), or 60° (6O, 6I)
- 8 Vertical Tee, Solid Bottom Trof Type (VT)
- 9 Straight Section, Solid Bottom Trof (SL)
- 10 Flanged Solid Cover (FS)
- 11 Barrier Strip-Straight Section (SB)
- 12 Barrier Strip-Flexible-Horizontal Fitting (FB)
- 13 Straight Section, Channel (SL)
- 14 Blind End (BE)
- 15 Box Connector (BC)
- 16 Angle Connector (CA)
- 17 Reducing Connector (CO)
- 18 Universal Curvilinear Connector (RC)

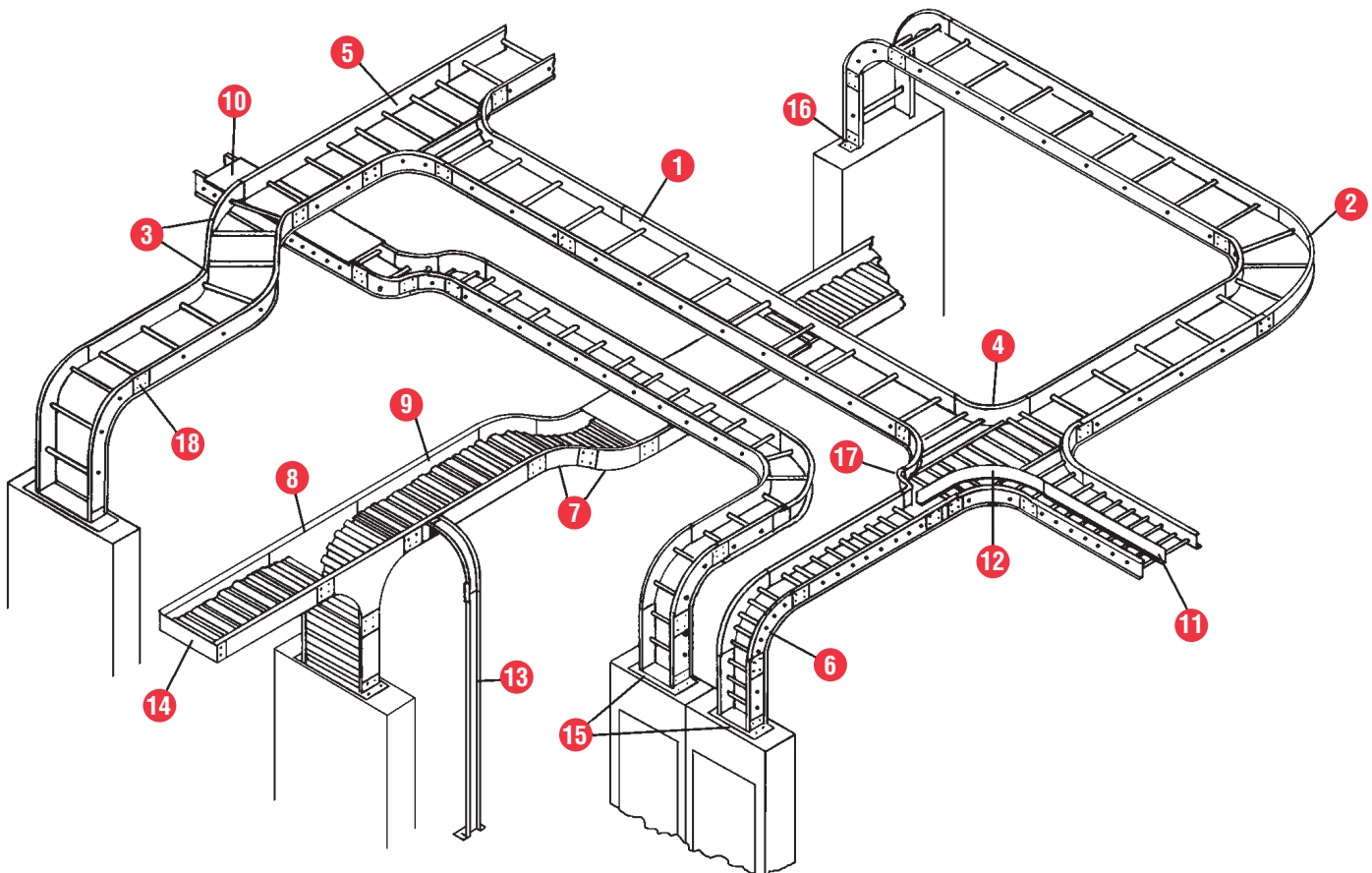

TYPES OF CABLE TRAY

Any assembly of cable tray straight sections, fittings and accessories that form a rigid system to support cables is a cable tray. The different types of tray designs are described below.

Ladder

A prefabricated metal structure consisting of two side rails connected by individual transverse members or rungs. Ladder tray is the most common and the most economical type of tray. It also provides maximum ventilation for cabling.

I-Beam

Cope I-Beam cable tray system provides long span capability and versatility. Cope I-Beam interfaces with existing "I" Beam configurations.

Ventilated Trof

A prefabricated metal structure with clear openings no greater than 4".

Trof cable trays are the best choice for smaller cables. Ventilated trofs offer some air-flow while completely eliminating cable sagging.

Solid Trof

A prefabricated metal structure consisting of a bottom with no openings within the cable bearing surface. Solid bottom cable trays completely eliminate cable sagging and offer the most protection for the cables.

Channel

A prefabricated metal structure consisting of a one-piece ventilated or solid bottom channel section not exceeding 6" in width.

Cope-Glas™

Fiberglass cable tray provides the answer to many adverse environments. Life cycle costs, long span capability and easy field modification make Cope Glas™ an ideal choice for industrial, chemical, and petro-chemical facilities.

Wire Basket

Provides the superior flexibility and ease of installation required by data-com installations. The exclusive Kwik- Latch™ system speeds cable tray installation.

MATERIALS AND FINISH

The material selection is based on the environmental conditions and economic considerations for the project.

Steel - Pre-Galvanized

Hot Dip Mill-Galvanized steel (ASTM-A-653-G90 CS) is zinc coated by a hot dip process. Steel strip from a coil is fed through a continuous zinc coater which cleans, fluxes and coats the steel with molten zinc. After cooling, the steel is recoiled. The pre-galvanized coating provides a total weight of 0.90 oz. of zinc for both sides of one square foot of material.

Mill galvanized ladder is made of pre-galvanized steel and generally used indoors or in locations not exposed to the elements or corrosives.

Steel - Hot Dip Galvanized After Fabrication

In hot dip galvanizing after fabrication (HDGAF), the finished part is immersed in a bath of molten zinc (ASTM 123). This method results in complete zinc coverage and a thicker coating than pregalvanized or electro-plated steel.

The zinc coating is typically 2.6 MIL or 1.5 oz./sq. ft. of surface area.

This is the coating of choice for applications where protection from severe corrosion is a design factor.

Stainless Steel

Type 304 and Type 316 stainless steel material in accordance with ASTM-A-240.

Aluminum

Aluminum material in accordance with AA-6063-T6. Aluminum trays are suitable for most outdoor applications and offer reductions in total installed costs.

Fiberglass

For extremely corrosive areas, Cope offers the most complete line of Fiberglass cable trays available. For a complete Cope "Cope-Glas™" catalog, please contact the factory or the Cope representative in your area.

Special Finishes

For extremely corrosive areas Cope can supply a PVC (polyvinyl chloride) coating over aluminum or uncoated steel. This is applied using the fluidized bed process to a nominal thickness of 12 mils.

Weathering steel is also available; contact factory for availability.

PRODUCT FEATURES

PRODUCT FEATURES

OVERVIEW

SWAGE LADDER

Is a structure consisting of two side rails, connected by individual rungs and is manufactured in accordance with NEMA Standard VE-1. Cope rungs are fastened to the side members by an exclusive swaging process. This assembly method insures a superior mechanical and electrical connection.

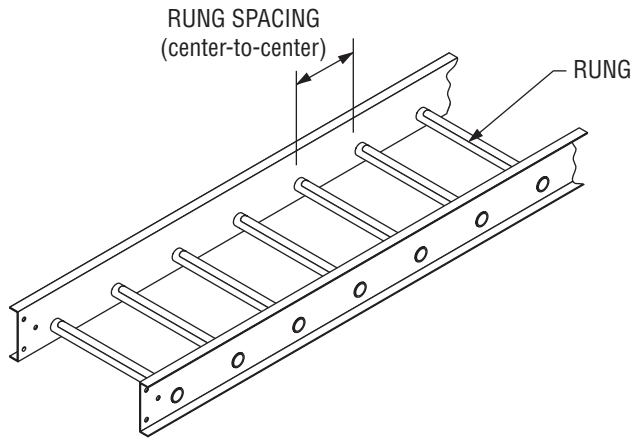

HAT

Is a prefabricated metal structure consisting of reinforced hat-shaped rungs, arc-welded to the side rails, and is manufactured to NEMA Standard VE-1. Cope Hat rungs are fastened to the side rails with an automatic, self-indexing MIG-arc-welding system, plug welding a ½" diameter zone. The superior strength of the Cope plug weld withstands the rigors of shipping, handling, erection, and cable support service.

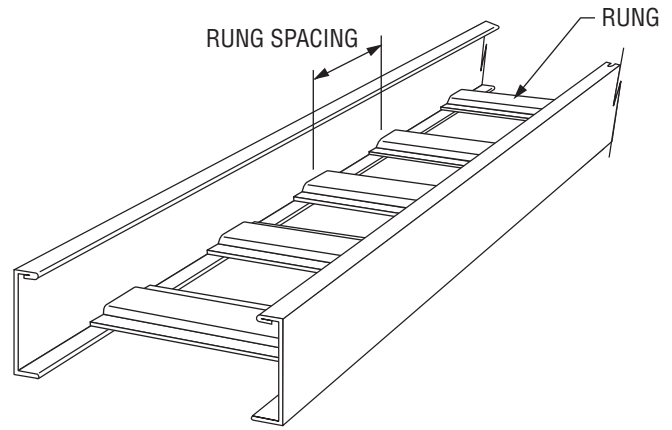

I-BEAM

Cope I-Beam cable tray system provides long span capability and versatility. Cope I-Beam interfaces with existing "I" Beam configurations.

Cope Offers a complete system of I-Beam products and accessories to meet all your project requirements.

In the following pages you'll find the products, accessories, specifications, and technical data for the Cope I-Beam cable tray system.

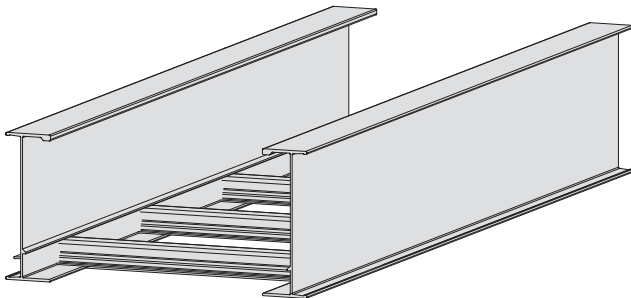

TROF

Is a prefabricated metal structure consisting of ventilated or solid bottoms, welded to the side rails, and are manufactured and tested to NEMA Standard VE-1. Straight sections, fittings (elbow, tees, crosses, reducers, etc.), and a full line of matching and interfacing accessories are available. Corrugations give great lateral rigidity to the bottom transmitting the load to the side rails. Lateral (transverse) deflection is nearly eliminated compared to rung type trofs where the rails are not continuously braced by the bottom. Cope Corrugated bottoms do NOT limit the tray load capacity.

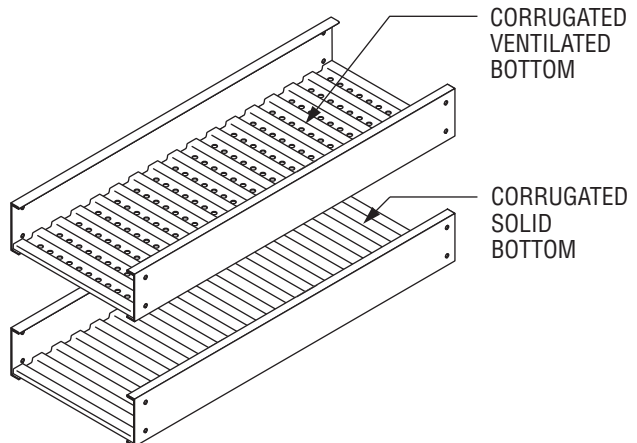

CHANNEL

Cope Channel supports single branches of power or multiconductor control cable or instrument tubing. Ideal for communication, fire alarm, or call station and clock cabling. A complete line of devices are available for interfacing with Cope Ladders and Cope Trofs.

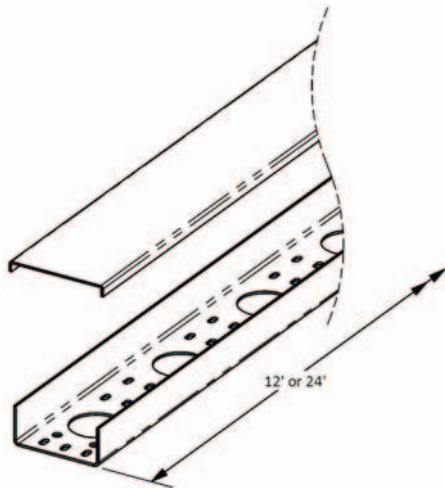

COPE-GLAS™

Engineers, designers, contractors, installers and end users have many reasons to choose COPE-GLAS cable tray for their power, signal, and control distribution support requirements. COPE-GLAS cable tray systems are available in a variety of sizes and styles. A standard or special design can be fabricated for any indoor or outdoor application regardless of size.

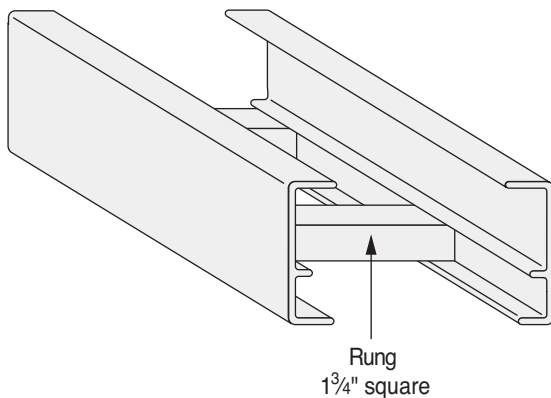

WIRE BASKET

Wire basket tray is a welded wire mesh cable management system produced from high strength steel wires. Wire basket tray is produced by first welding a net, forming the channel, and then finishing after fabrication. The 2" x 4" mesh permits continuous airflow to help prevent heat buildup. In addition this unique open design prevents the buildup of dust, contaminants, and bacterial proliferation.

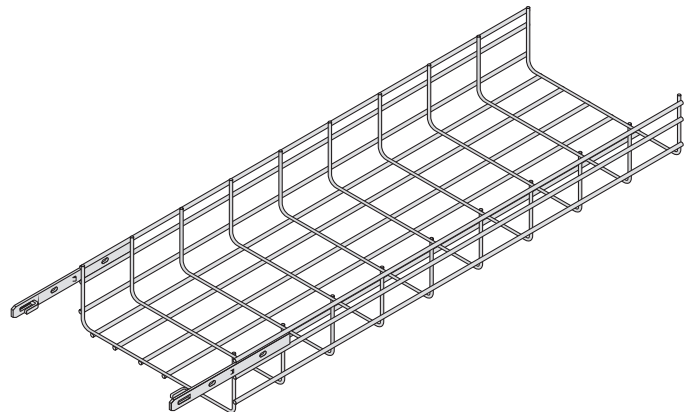

PRODUCT FEATURES

ASSOCIATED PRODUCTS

POWER-STRUT® METAL FRAMING SYSTEM

Trapeze Support System

Power-Strut metal framing is ideal for electrical and mechanical pipe support applications.

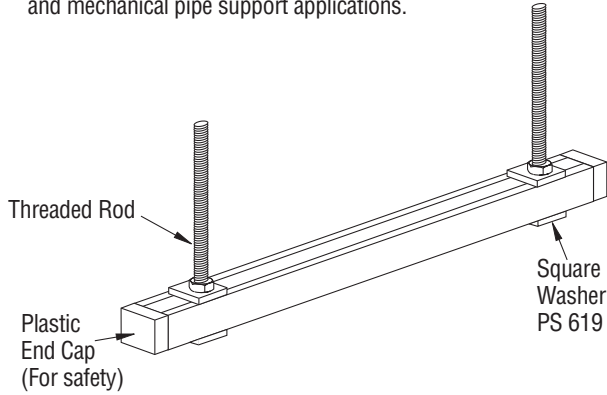

Acceptable Methods to Hang Channels

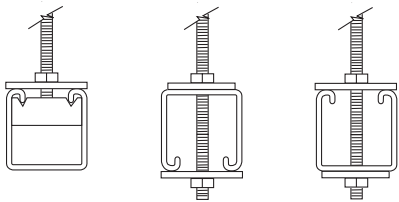

Pre-slotted channel allow through channel connections

Overhead Multi-Use Support Systems Using Channel Attached to "I" Beams

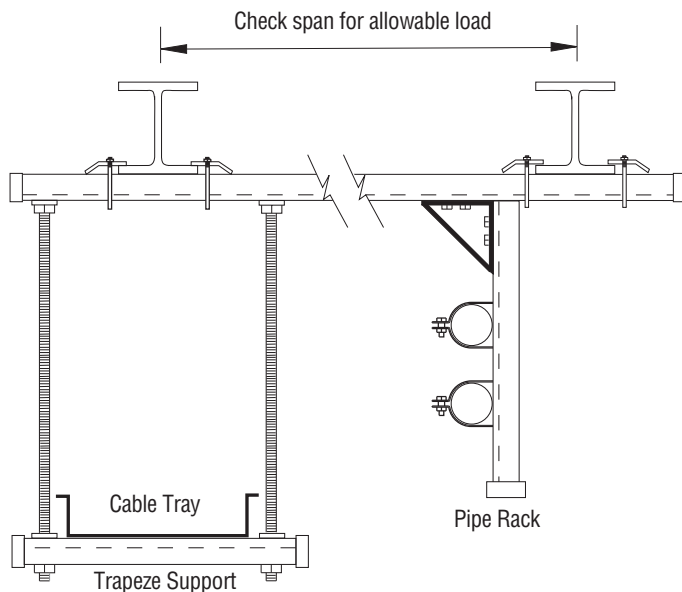

Standard Channel and Fitting Assembly

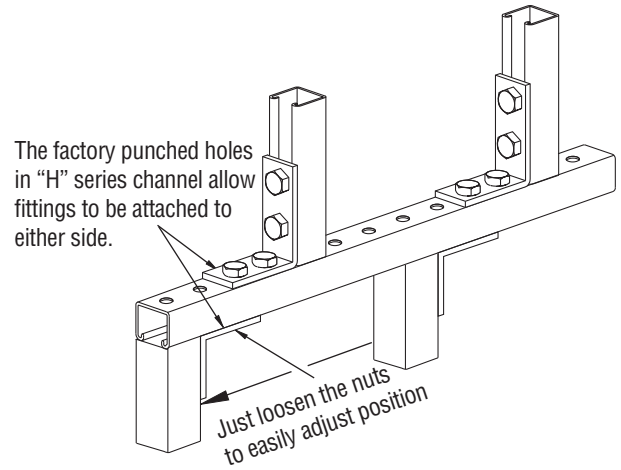

Ganged Pipe Support

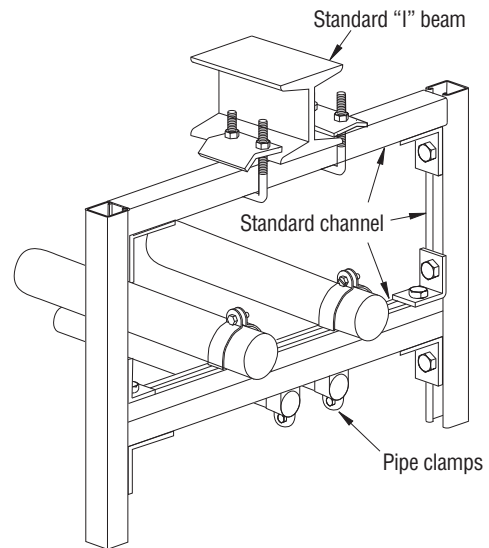

Stock brackets are available in lengths from 6" to 36"

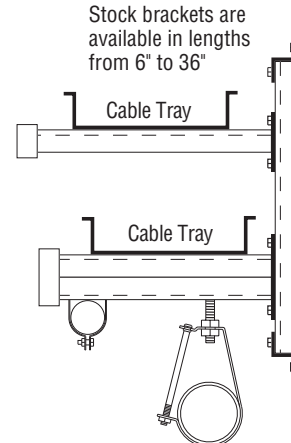

*Reference your Power-Strut Catalog, or Power-Strut.us for more information

2



STANDARDS

INDUSTRY STANDARDS AND GUIDELINES

Cope products are produced in accordance with the standards of NEMA (National Electrical Manufacturers Association) and in accordance with CSA (Canadian Standards Association).

This section presents standards and guidelines for products and installation. They can be used as a reference for specifications and procedures.

SECTION 1 - REFERENCED STANDARDS & DEFINITIONS

1.1 REFERENCED STANDARDS

In this publication, reference is made to the standards listed below. Copies are available from the indicated source.

ANSI/NFPA 70-93 National Electrical Code*

American National Standards Institute

11 West 42nd Street
New York, NY 10036

National Fire Protection Association
1 Batterymarch Park
Quincy, Massachusetts
USA 02169-7471

- A123** Zinc (Hot-Dip Galvanized) Coatings on Iron and Steel Products, Specifications for
- A653** General Requirements, Steel Sheet, Zinc-Coated (Galvanized) by the Hot Dip Process, Specifications for
- B633** Electrodeposited Coatings of Zinc on Iron and Steel, Specifications for
- B766** Electrodeposited Coatings of Cadmium, Specification for

ASTM International
1916 Race Street
Philadelphia, PA 19103

1.2 DEFINITIONS

Metallic Cable Tray System - An assembly of cable tray straight sections, fittings, and accessories that forms a rigid structural system to support cables.

Ladder Cable Tray - A prefabricated metal structure consisting of two longitudinal side rails connected by individual transverse members.

Trof Cable Tray - A prefabricated metal structure consisting of a ventilated bottom pan or rungs* within integral or separate longitudinal side rails.

*The cable tray bottom will have openings sufficient for the passage of air and utilize 75 percent or less of the plan area of the surface to support cables. The maximum distance between cable support surfaces shall not exceed 100 mm (4") in the direction parallel to the cable tray side rails.

Solid Bottom Cable Tray - A prefabricated metal structure consisting of a bottom with no openings within integral or separate longitudinal side rails.

Straight Section - A length of cable tray which has no change in direction or size.

Cable Tray Fitting - A device which is used to change the direction or size of a cable tray system.

Cable Tray Connector (Splice Plate) - A device which joins cable tray straight sections and fittings, or both.

The basic types of connectors (splice plates) are:

Rigid
Expansion
Adjustable
Reducer

Fasteners - Screws, nuts, bolts, washers, rivets, pins, and other items used to assemble a cable tray system.

Horizontal Elbow (Horizontal Bend) - A cable tray fitting which changes the direction in the same plane. Standard degrees of bend are 90°, 60°, 45°, and 30°.

Horizontal Tee - A cable tray fitting which is suitable for joining cable trays in three directions at 90° intervals in the same plane.

Horizontal Cross - A cable tray fitting which is suitable for joining cable trays in four directions at 90° intervals in the same plane.

Vertical Elbow (Vertical Bend) - A cable tray fitting which changes direction to a different plane. Standard degrees of bend are 90°, 60°, 45°, and 30°. An inside vertical elbow changes direction upward from the horizontal plane.

An outside vertical elbow changes direction downward from the horizontal plane.

Vertical Tee - A cable tray fitting which is suitable for joining cable trays in three different directions at 90° intervals in different planes.

Reducer (Straight, Right Hand, Left Hand) - A cable tray fitting which is suitable for joining cable trays of different widths in the same plane.

A straight reducer has two symmetrical offset sides.

A right-hand reducer, when viewed from the large end, has a straight side on the right.

A left-hand reducer, when viewed from the large end, has a straight side on the left.

Channel Cable Tray - A prefabricated metal structure formed from one piece of metal and having either a ventilated bottom or solid-bottom. The channel shall not exceed 152 mm (6") in width.

Accessories - Devices which are used to supplement the function or plane of straight sections and fittings, and include such items as adjustable splices (horizontal and vertical), dropouts, covers, conduit adapters, hold-down devices and dividers.

Cable Tray Support – A device which provides adequate means for supporting cable tray sections and fittings.

The basic types of cable tray supports are:

- Cantilever bracket
- Trapeze
- Single rod suspension.

Cable Tray Support Span – The distance between the center lines of supports.

SECTION 2 – MANUFACTURING STANDARDS

2.1 MATERIALS

Cable tray systems shall be made of either corrosion-resistant metal or metal with a corrosion-resistant finish. Aluminum and stainless steel alloys are inherently corrosion-resistant and no finish coating is required in most environments.

2.2 FINISHES

2.2.1 Carbon steel used for cable trays shall be protected against corrosion by one of the following processes:

A. Hot-dip mill galvanized in accordance with ASTM Publication No. A653.*

*Coating designation G90 of ASTM 653 has an average zinc coating weight of 1.25 oz. per square foot (0.381 kg/m²) of steel total coating on both surfaces (1.06 mils or 0.027mm) average thickness per side).

Hot-dip mill galvanized coatings are produced by continuous rolling steel sheets or strips in coils through a bath of molten zinc. The process involves pre-treating the steel to make the surface react readily with molten zinc as the strip moves through the bath at high speeds. During fabrication where slitting, forming, cutting, or welding is performed, the cut edges and heat-affected zone of welding are subject to superficial oxidation. These areas are then protected through electrolytic action of the adjacent zinc surfaces. The coating is smooth, ductile, and adherent.

B. Hot-dip galvanized after fabrication in accordance with ASTM Publication No. A123. Grade 65. It is important to specify ASTM A653 or ASTM A123 to insure the specific coating is furnished.

Grade 65 of ASTM A123 has an average zinc coating weight of 1.50 oz. per square foot (0.46 kg/m²) (2.55 mils or 0.064mm) average thickness per side).

Fabricated products which are hot-dip galvanized are thoroughly cleaned, fluxed, and immersed into a bath of molten zinc where they react to form a

metallurgical bonded zinc coating. Normal oxidation of the galvanized surfaces will, in a short period of time, appear as a dull gray or white coating. Some degree of roughness and variations of thickness can be expected due to the hot dipping process. Because the galvanizing process takes place at the low end of the stress-relieving temperature range, some stress relief occurs and some distortion or warping may result.

C. Other equivalent commercially available coatings.

2.2.2 Steel nuts and bolts shall be protected against corrosion by one of the following processes:

- A. ASTM Publication No. B633
- B. ASTM Publication No. B766
- C. Other equivalent commercially available coatings.

2.2.3 Where metallic cable tray is intended for installation in highly corrosive environments, including most alkaline and acidic conditions, further protection against corrosion shall be provided by one of the following processes:

A. PVC (Polyvinylchloride) – A PVC coating shall be applied in a fluidized bed or by electrostatic spray. The coating thickness shall be 15 mils (0.381mm) ± 5 mils (±0.127mm).

Items to be protected shall be thoroughly cleaned, primed, and then coated with a fine grain UV (ultraviolet) stabilized vinyl plastic powder.

All field cuts and damaged areas of coated tray shall be repaired with a compatible PVC compound to ensure a coating integrity.

A PVC coating is generally applied to bare steel cable tray but can also be applied in aluminum cable tray. PVC is not recommended as a coating on galvanized steel cable trays because of rough surfaces and gas emissions which cause voids and adhesion problems.

B. Other equivalent commercially available coatings.

2.3 DIMENSIONS

2.3.1 General

Plus or minus values stated reflect the range of nominal dimensions in cable tray designs and are not intended to represent manufacturing tolerances.

2.3.2 Ladder Trays

1. Lengths of Straight Sections – NEMA - 12' (3,660mm) ±³/₁₆" (4.76mm) and 24' (7,320mm) ±⁵/₁₆" (7.94mm), not including connectors if attached. CSA - 10' (3,000mm) ±³/₁₆" (4.76mm) and 20' (6,000mm) ±⁵/₁₆" (7.94mm), not including connectors if attached.

2. Widths - 6", 9", 12", 18", 24", 30", and 36" (152mm, 225mm, 305mm, 457mm, 610mm, 762mm and 914mm), 1/4" (6.35mm) inside dimension. Overall widths shall not exceed inside widths by more than 4" (102mm).

3. Depths - Inside depths shall be 3", 4", 5", and 6" (76.2mm, 102mm, 127.0mm, and 152mm), $\pm\frac{3}{8}$ " (9.53mm). Outside depths shall not exceed inside depths by more than 1/4" (31.7mm).

4. Rung Spacing on Straight Sections - 6", 9", 12", or 18" (152mm, 229mm, 305mm, or 457mm) on centers.

5. Radii - 12", 24", and 36" (305mm, 610mm, and 914mm).

6. Degree of Arc for Elbows - 30°, 45°, 60°, and 90°.

2.3.3 Trof Trays

1. Lengths of Straight Sections - NEMA - 12' (3660mm) $\pm\frac{3}{16}$ " (4.76mm) and 24' (7320mm) $\pm\frac{5}{16}$ " (7.94mm), not including connectors if attached. CSA - 10' (3000mm) $\pm\frac{3}{16}$ " (4.76mm) and 20' (6,000mm) $\pm\frac{5}{16}$ " (7.94mm), not including connectors if attached.

2. Widths - 6", 9", 12", 18", 24", 30", and 36" (152mm, 225mm, 305mm, 457mm, 610mm, 762mm and 914mm), 1/4" (6.35mm), inside dimension. Overall widths shall not exceed inside widths by more than 4" (102mm).

3. Depths - Inside depths shall be 3", 4", 5", and 6" (76.2mm, 102mm, 127mm, and 152mm), $\pm\frac{3}{8}$ " (9.53mm). Outside depths shall not exceed inside depths by more than 1/4" (31.7mm).

4. Radii - 12", 24", and 36" (305mm, 610mm, and 914mm).

5. Degrees of Arc for Elbows - 30°, 45°, 60°, and 90°.

6. Transverse Elements - The maximum open spacing between transverse elements shall be 4" (102mm) measured in a direction parallel to the tray side rails.

2.3.4 Solid-Bottom Trays

1. Lengths of Straight Sections NEMA - 12' (3660mm) $\pm\frac{3}{16}$ " (4.76mm) and 24' (7320mm) $\pm\frac{5}{16}$ " (7.94mm), not including connectors if attached. CSA - 10' (3000mm) $\pm\frac{3}{16}$ " (4.76mm) and 20' (6,000mm) $\pm\frac{5}{16}$ " (7.94mm), not including connectors if attached.

2. Widths - 6, 9, 12, 18, 24, 30, and 36" (152mm, 225mm, 305mm, 457mm, 610mm, 762mm and 914mm) $\pm\frac{1}{4}$ " (6.35mm), inside dimension. Overall widths shall not exceed inside widths by more than 4" (102mm).

3. Depths - inside depths shall be 3", 4", 5", and 6" (76.2mm, 102mm, 127mm, and 152mm), $\pm\frac{3}{8}$ " (9.53mm). Outside depths shall not exceed inside depths by more than 1/4" (31.7mm).

4. Radii - 12", 24", and 36" (305mm, 610mm, and 914mm).

5. Degree of Arc for Elbows - 30°, 45°, 60°, and 90°.

6. Bottom - Bottom is solid.

2.3.5 Channel Trays

1. Lengths of Straight Sections - 12' (3660mm) $\pm\frac{3}{16}$ " (4.76mm) and 24' (7320mm) $\pm\frac{5}{16}$ " (7.94mm), not including connectors if attached.

2. Widths - 3", 4", and 6" (76.2mm, 102mm, and 152mm), 1/4" (6.35mm), inside dimension.

3. Depths - 1/4" to 1/4" (31.7mm to 44.4mm) outside dimensions.

4. Radii - 12", 24", and 36" (305mm, 610mm, and 914mm).

5. Degree of Arc for Elbows - 30°, 45°, 60°, and 90°.

2.4 PROTECTION OF CABLE INSULATION

The inside of cable tray systems shall not have sharp edges, burrs, or projections which can damage cable insulation.

2.5 FITTINGS

The design and construction of fittings shall be based on the assumption that they will be supported in accordance with the recommendations given in 6.6 for support locations.

2.6 MARKING OF TRAYS WHEN USED AS EQUIPMENT GROUNDING CONDUCTORS

When steel or aluminum cable tray systems are used as equipment grounding conductors, cable tray sections and fittings shall be marked to show the minimum cross-sectional area in accordance with the Article 392 of the National Electrical Code*.

SECTION 3 - PERFORMANCE STANDARDS & LOAD/SPAN CLASS DESIGNATIONS

3.1 WORKING (ALLOWABLE) LOAD CAPACITY

The working (allowable) load capacity represents the ability of a cable tray to support the static weight of cables. It is equivalent to the destruction load capacity, as determined by testing in accordance with 4.1 divided by a safety factor of 1.5.

3.2 LOAD/SPAN CLASS DESIGNATIONS

There shall be three working load categories of cable tray:*

- 50 lbs/linear ft. (74.4 kg/m) (Symbol A)
- 75 lbs/linear ft. (111.6 kg/m) (Symbol B)
- 100 lbs./linear ft. (148.8 kg/m) (Symbol C) and, four support span categories of:
 - 8' (2.44m), 12' (3.66m), 16' (4.87m), 20' (6.09m)

Utilizing these above, load/span class designations are presented in the table below:

LOAD/SPAN CLASS DESIGNATIONS

Working Lbs./Ft	Load (kg/m)	Support Feet	Span (m)	NEMA Class
50	(74.4)	8	(2.44)	8A
75	(116.6)	8	(2.44)	8B
100	(148.8)	8	(2.44)	8C
50	(74.4)	12	(3.66)	12A
75	(116.6)	12	(3.66)	12B
100	(148.8)	12	(3.66)	12C
50	(74.4)	16	(4.87)	16A
75	(116.6)	16	(4.87)	16B
100	(148.8)	16	(4.87)	16C
50	(74.4)	20	(6.09)	20A
75	(116.6)	20	(6.09)	20B
100	(148.8)	20	(6.09)	20C

NOTE 1 - The above working loads are for cable only; when considering applications requiring concentrated static load, see 6.2.

NOTE 2 - These designations do not apply to channel tray, and the manufacturer should be consulted.

NOTE 3 - For deflection see 6.1.

SECTION 4 - TEST STANDARDS

4.1 DESTRUCTION LOAD TEST

4.1.1 Test Specimen

For each design of cable tray, two separate tests shall be made. An un-spliced straight section of the widest width shall be used in each test.

For ladder type cable trays rung spacing shall be 12" on center.

Differences in gauge, height of side rails, rung or bottom to side rail connection, or the configuration of any part constitute a different design.

4.1.2 Type and Length of Span

Test spans shall be simple beam spans with free unrestrained ends. Trays shall not have side restraints. Span lengths shall be as specified $\pm 1/2$ " (38 mm).

4.1.3 Orientation of Specimens

Specimens shall be tested in a horizontal position. The total length of the test specimen shall be not more than the specified span length plus 20%. Any overhang shall be equal.

4.1.4 Supports

Each end of the specimen shall be supported by an 1 1/8" (30 mm) wide by 3/4" (19 mm) high steel bar(s) with a 120° "V" notch cut in its bottom to a depth of 3/16" (5 mm). The "V" notch shall rest on a 1" (25 mm) solid round steel bar which is securely fastened to a rigid base, or the

specimen shall be supported directly on a 2 1/2" (65 mm) maximum diameter round steel bar or heavy wall steel tube fastened to rigid base.

4.1.5 Loading Material

Loading material shall be steel strips, lead ingots, or other loading material.

Steel strips shall have rounded or de-burred edges, a maximum thickness of 1/8" (3 mm), a width of 4" (100 mm), and a maximum length of 24' (7320 mm).

Five lead ingots, each weighing approximately 5 pounds (2.3 kg), shall be interconnected across corners into a string of 5 ingots approximately 22" (550 mm) long. Individual ingots are normally hexagonal, approximately 3" (75 mm) in diameter, and 1 1/2" (38 mm) deep.

Other loading material shall have a maximum weight of 10 pounds (4.5 kg), a maximum width of 5" (125 mm), and a maximum length of 12" (300 mm).

4.1.6 Loading

All specimens shall be loaded to destruction. The load shall be applied in at least 10 increments which are approximately equal.

Loading shall be uniformly distributed for the length and breadth of the specimen except that the loading material shall be not closer than 1/2" (13 mm) nor further than 1" (25 mm) from the innermost elements of the side rails. It shall be arranged across the tray with a minimum of 3/8" (10 mm) between stacks so that the loading material does not bridge transversely. All loading material shall be placed between the supports without overhanging.

For loading weight in a ladder-type tray, it shall be permissible to cover the bottom of the tray between supports with a flat sheet of No. 9 gauge (3.8 mm) flattened expanded material not more than 3' (900 mm) long and with a wire hole size of 3/4" (19 mm), or a flat sheet of No. 16 gauge (1.5 mm) sheet steel not more than 3' (900 mm) long. The expanded metal or sheet steel shall not be fastened to the tray and shall be no closer than 1/2" (13 mm) to the side rails. The 3' (900 mm) lengths shall not overlap by more than 2" (50 mm). The weight of the expanded metal or sheet steel shall be added to the total weight of the loading material.

4.1.7 Destruction Load Capacity

The total weight of the loading material on the cable tray at the time it is destroyed less the last incremental weight added shall be considered to be the destruction load capacity of the cable tray. The Rated Load Capacity shall be the Destruction Load Capacity divided by a safety factor of 1.5.

4.1.8 Interpolation & Extrapolation of Test Data

When allowable load and deflection data are determined by load tests, values for span lengths not tested shall be determined by interpolation from a curve based on values for a minimum of the two (2) span lengths. Extrapolation for shorter span lengths is permissible using the formula below, however extrapolation shall not be used for span lengths longer than the longest span length tested.

Where: $W2 = (W1 \times L12) / L22$

W1 = Tested Load, lbs/ft (kg/m)

W2 = Load on Shorter Span, lbs/ft (kg/m)

L1 = Tested Span Length, ft (m)

L2 = Shorter Span Length, ft (m)

4.2 RESIDUAL DEFLECTION TEST

Determine the Minimum Test Load (MTL) from the formula:

Where: $MTL = 1.5 * L * W$

1.5 = Safety Factor

L = Span Length, ft (m)

W = Rated Load at Span Length, lbs/ft (kg/m)

A minimum of two (2) tray specimens shall be tested. The following procedure shall be used for each tray.

1. Load tray to 10% of MTL. Measure the vertical deflection of the tray at two (2) points along the line midway between the supports and at right angles to the longitudinal axis of the tray. The two points shall be at the midpoint of the span and under of each side rail. The two readings shall be considered to be the initial deflection of the tray.

2. Continue loading until the Rated Load (W) has been applied. Measure the deflection at the same points as for the initial deflection measurement above.

3. Continue loading until the Minimum Test Load (MTL) has been applied. Remove the all load from the tray and wait 15 minutes before measuring the deflection at the previous two points. This final measurement is known as the residual deflection of the tray specimen.

Average the residual deflections of the two (2) test specimens. This shall be considered the final result. However, if the residual deflection for either specimen is > 80% of the initial deflection, and in addition, deviates from the average by more than 10%, then two more specimens shall be tested. The average of the three highest values at the point of measurement of the four specimens shall be considered the final result.

4.3 ELECTRICAL CONTINUITY OF CONNECTIONS

4.3.1 Test Specimen

Each specimen shall consist of two 24" (600 mm) lengths of side rail connected by the manufactures standard splice.

4.3.2 Resistance Test Procedure

Each specimen should be joined together, using the mechanical connector, and following the instructions provided by the manufacturer.

A current of 30 amperes DC shall be passed through the specimen and the resistance measured between two points 1/16" (1.6 mm) from each side of the splice. The net resistance of the joint shall be not more than 0.00033 ohm as computed from the measured voltage drop and the current passing through the specimen. The ambient temperature of the specimen shall be between 60° and 90°F (15° to 35°C). The current shall be applied to the specimen at least 12" (300 mm) from the splice joint.

SECTION 5 - SPECIFICATIONS & DRAWINGS

5.1 DATA TO APPEAR IN SPECIFICATIONS

The following statement and minimum data, when applicable, should appear in all cable tray specifications:

Cable tray shall be manufactured and installed in accordance with NEMA Standard VE 1-2002
Load / Support Span Class Designation (see Table 1)
Type (see Section 1.2 Definitions)
Material (see Section 2.1)
Finish (see Section 2.2)
Tray Length (see Section 2.3)
Width (see Section 2.3)
Inside Depth (see Section 2.3)
Rung Spacing (see Section 2.3)
Fitting Radius (see Section 2.3).

5.2 DATA TO APPEAR ON DRAWINGS

The following minimum data should appear on all cable tray drawings:

Type (ladder, trof, etc.)
Width(s)
Load depth
Straight section, fitting, or accessory
Fitting radii
Elevation (bottom of tray)
Vertical and horizontal changes in direction
Clearances-vertical and horizontal
Number of trays (if there is a stack of trays)
Support span
Show graphic scale

SECTION 6 - APPLICATION INFORMATION

6.1 DEFLECTION

Under normal applications deflection limitations should not be included in design criteria for cable trays. However, if unusual or special conditions exist, the manufacturer should be consulted. Limitations of deflection for

aesthetic purpose only can result in an over-designed tray system.

6.2 CONCENTRATED STATIC LOAD (If Required by User)

A concentrated static load is not included in the Load/ Span Designations NEMA VE-1, Table 1. Some user applications may require that a given concentrated static load be imposed over and above the working load.

Such a concentrated static load represents a static weight applied between the side rails at midspan. When so specified, the concentrated static load may be converted to an equivalent, uniform load (W_e) in pounds per linear foot (kilograms per meter) using the formula: (see NEMA VE-2, Section 4.8.2)

$$W_e = 2 \times (\text{Concentrated Static Load}) / \text{span length, ft. (m)}$$

The value for W_e will be added to the static weight of cables in the tray. This combined load may be used to select the appropriate load/span designation NEMA VE-1, Table 1. If the combined load exceeds the working load shown in the load/span designation table, the manufacturer should be consulted.

6.3 WARNING! WALKWAYS

Inasmuch as cable tray is designed as a support for power or control cables, or both, and is not intended or designed to be a walkway for personnel, the user is urged to display appropriate warnings cautioning against the use of this support as a walkway. The following language is suggested:

Warning! Not to be used as a walkway, ladder or support for personnel. To be used only as a mechanical support for cables and tubing.

6.4 FITTINGS

Changes in direction should be mechanically continuous and accomplished by use of fittings having dimensions in accordance with 2.5.

6.5 SUPPORTS

Supports for cable trays should provide strength and working load capacity sufficient to meet the load requirement of the cable tray systems.

Horizontal and vertical tray supports should provide an adequate bearing surface for the tray and should have provisions for hold down clamps or fasteners.

In addition, vertical tray supports should provide secured means for fastening cable trays to supports.

6.6 SUPPORT LOCATIONS

For complete information on cable tray support, please refer to NEMA Standard VE-2-2006.

6.6.1 Horizontal Cable Tray Straight Sections

Horizontal cable tray straight sections should be supported at intervals not to exceed the support span for the appropriate NEMA Class Designation shown in NEMA VE-1, Table

1. Un-spliced straight sections should be used on all simple spans and on end spans of continuous span runs. A support should be located within 2' (610mm) of each side of an expansion connector. Straight section lengths should be equal to or greater than the span length to ensure not more than one splice between supports.

6.6.2 Horizontal Cable Tray Fittings

1. Horizontal Elbow Supports for horizontal tray fittings should be placed within 2' (600 mm) of each fitting extremity, and as follows: (See page 22, Figure 6-1 for a graphic presentation of fitting supports.)

- (a) 90° supports at the 45° point of arc.
- (b) 60° supports at the 30° point of arc.
- (c) 45° supports at the 22½° point of arc (except for the 12" (300 mm) radii).
- (d) 30° supports at the 15° point of arc (except for the 12" (300 mm) radii).

2. Horizontal Tee Supports shall be placed within 2' (600 mm) of each of the three openings connected to other cable tray items for 12" (300 mm) radius fittings. On all other radii, at least one support should be placed under each side rail of the horizontal tee, preferably as shown in Figure 6-2, page 22.

3. Horizontal Cross Supports shall be placed within 2' (600 mm) of each of the four openings connected to other cable tray items for 12" (300 mm) radius fittings. On all other radii, at least one support should be placed under each side rail of the horizontal cross, preferably as shown in Figure 6-3, page 22.

4. Horizontal Wye Supports shall be placed within 2' of each of the three openings connected to other cable tray items, and at 22½° point of the arc adjacent to the branch as shown in Figure 6-4, page 22.

5. Reducer Supports shall be placed within 2' (600 mm) of each fitting extremity as shown in Figure 6-5 and 6-6, page 22.

6. Vertical Cable Tray Elbows should be supported at the top of runs at each end of the fitting. Vertical cable tray elbows at the bottom of runs should be supported at the top of the elbow and within 2' (600 mm) of the lower extremity of the elbow as shown in Figure 6-7, page 22.

7. Vertical Cable Tray Tees should be supported within 2' (600 mm) of each fitting extremity as shown in Figure 6-8, page 22.

NEMA STANDARDS

6.6.3 Vertical Straight Sections

Vertical straight sections should be supported indoors at appropriate intervals permitted by the building structure; outdoor support intervals should be determined by wind loading. The maximum distance between vertical supports should not exceed 24' (7,320 mm) on centers.

6.6.4 Sloping Trays

Sloping trays should be supported at intervals not exceeding those for horizontal trays of the same design for the same installation.

6.6.5 Fittings as End of Run

A fitting which is used as an end of the run dropout should have a support attached to it, firmly reinforcing the fitting.

6.7 PROTECTION OF CABLE INSULATION

The inside of cable tray systems should present no sharp edges, burrs, or projections which could damage cable insulation.

6.8 THERMAL CONTRACTION AND EXPANSION

It is important that thermal contraction and expansion be considered when installing cable tray systems. If it is determined that expansion connectors are required, reference should be made to table on page 19 for maximum spacing between supports and to the table on page 19 to determine the proper splice plate setting.

The cable tray should be securely fixed at the support nearest to its midpoint between the expansion connectors and secured by expansion guides at all other support locations. The cable tray should be permitted longitudinal movement in both directions from that fixed point towards the expansion connectors.

Accurate gap setting at the time of installation is necessary for the proper operation of the expansion connectors. The following procedure should assist the installer in determining the correct gap:

Step 1 - Plot the highest expected cable tray metal temperature on the maximum temperature vertical axis. Example's Value = 100°F. (See page 19).

Step 2 - Plot the lowest expected cable tray metal temperature on the minimum temperature vertical axis. Example's Value = -28° F.

Step 3 - Draw a line between these maximum and minimum temperature points on the two vertical axis.

Step 4 - To determine the required expansion joint gap setting: Plot the cable tray metal temperature at the time of the cable tray installation on the Maximum temperature vertical axis. (Example's Value = 50° F).

Project over from the 50°F point on the maximum temperature vertical axis to an intersection with the line

between the maximum and minimum cable tray metal temperatures. From this intersection point, project down to the gap setting horizontal axis to find the correct gap setting value (Example's Value: 3/8" gap setting). This is the length of the gap to be set between the cable tray sections at the expansion joint splice plate location.

NOTE: THE MAXIMUM GAP SPACE BETWEEN TRAY SECTIONS IS 1" (25 MM).

6.9 CABLE INSTALLATION

When installing cable in cable tray, it is important that care and planning be exercised so that the cable or the cable tray is not damaged or destroyed. The cable manufacturer should be contacted for maximum pulling tensions and minimum bending radii, and advice on prevention of "egging" or deformation of cable jacketing or shielding.

NEMA CLASS

The NEMA Classifications for Cable Tray were established to simplify and standardize the specification of Cable Tray. This classification is based on the working load (the total weight of the cables) and the support span (the distance between supports). The NEMA VE1 specifications are contained in Section 2.

Atkore International is a member of NEMA and offers designs in all NEMA cable tray classifications.

Cable Load/Working Load

The Cable Load or the working load is the total weight of the cables to be placed in the tray. The NEMA classes are based on cable loads of 50#, 75#, and 100# per Lineal Foot. This is the total weight of cables in the tray. For purposes of selecting a suitable tray, this weight should be rounded off to the next higher NEMA working (allowable) load.

Support Spans

Support span is the distance between the supports. The NEMA standard support spans are based on 8', 12', 16' and 20'.

NEMA LOAD/SPAN DESIGNATIONS

Class Designation	Support Span Feet	Working Load Lbs./Linear Ft.
8A	8	50
8B	8	75
8C	8	100
12A	12	50
12B	12	75
12C	12	100
16A	16	50
16B	16	75
16C	16	100
20A	20	50
20B	20	75
20C	20	100

NEMA Classes

The following table summarizes the NEMA classes based on cable/working load and support span described previously.

To determine what NEMA load class is required for your project, refer to the National Electrical Code® (NEC®). Determine type of cable and the appropriate cable tray type based on NEC® Article 392 guidelines. Establish the number and type of cables required in each cable tray run; then calculate the total number of square inches of cable in the run. Using NEC®, Article 392.9, Tables 392.9(A), 392.9(C), 392.9(E), 392.9(F), and 392.10(A), determine the allowable cable fill for the type of cable tray and cable being used. The number of square inches of installed cable divided by the allowable cable fill percentage will determine the size of the cable tray needed. Calculated the total weight of cables (in pounds per linear foot) to be installed in the cable tray. Determine the frequency of cable tray supports (span). **Example:** Project requires 50 multiple conductor cables in a tray. The cable is .5" in diameter and weighs .3 pounds per foot. The tray selected is a ventilated bottom trof tray and will be supported every 12 feet. **Tray Size Calculation:** Area = 3.14 x .252 = 0.19625 sq. in. per cable. 50 cables multiplied by .019625 sq. in. = 9.8125 total sq inches of cable. 9.8125 sq. in. divided by .5 (% fill allowed) = 19.625 sq. in. minimum needed within the tray. Divide 19.625 sq. in. by 4" (load depth of a tray) = 4.9" wide tray minimum. The closest standard tray is a 4" Load Depth x 6" Wide. **Weight Calculation:** 50 cables multiplied by .3 pounds per foot = 15 pounds per foot of cable. Select a NEMA 12A rated tray which will hold 50 pounds of weight when supported every 12 feet.

OTHER LOADING CONSIDERATIONS

It is important to note that when specifying loading requirements, there are other loading factors that may need to be considered over and above the actual cable loads.

Destruction Load Capacity

The total weight in the tray which causes the tray to collapse is called the "destruction load capacity". When trays do collapse, they generally do so by premature lateral buckling (compression) of the top flange.

Concentrated Loads

A concentrated load is a static weight applied between the side rails at mid span. When specified, these concentrated static loads may be converted to an equivalent uniform load (We), in pounds per lineal foot, using the following formula:

$$We = 2 * \frac{\text{Concentrated Load}}{\text{Support Span}}$$

This load (We) is then added to the static weight of the cable before selecting the appropriate NEMA load span designation.

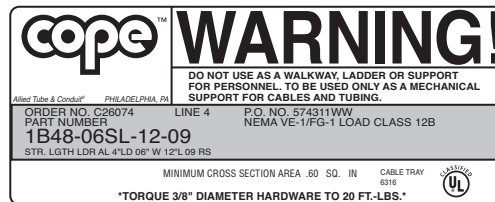

Please note per the NEMA VE-1 guidelines all Cope® Cable Trays are labeled as follows:

ENVIRONMENTAL LOAD CONSIDERATIONS

Environmental loads should be considered in any outdoor installation, particularly when cable tray is to be covered. These loads include wind loads, snow loads, and ice loads. Specific information data concerning these loads can be obtained by contacting the Cope Factory. Other sources for this type of information can be obtained through the local building codes.

It is important to note that these types of loads need to be considered in terms of pounds per square feet, unlike the cable loads, which are calculated in terms of pounds per linear foot.

The following are general guidelines to follow:

Wind Loads

Additional wind loads need to be taken into account for all outdoor cable tray installations. In calculating wind loads, the most sever loading condition are wind pressures normal to the cable tray side rails. The following table outlines corresponding wind pressure associated with various wind velocities.

WIND PRESSURE			
V(mph)	P(lbs/ft2)	V(mph)	P(lbs/ft2)
15	0.58	85	18.5
20	1.02	90	20.7
25	1.6	95	23.1
30	2.3	100	25.6
35	3.13	105	28.2
40	4.09	110	30.9
45	5.18	115	33.8
50	6.39	120	36.8
55	7.73	125	40
60	9.21	130	43.3
65	10.8	135	46.6
70	12.5	140	50.1
75	14.4	145	53.8
80	16.4	150	57.6

*These values are calculated for an air density of 0.0765 lbs/ft3, representing a temperature of 60°F and barometric pressure of 14.7 lbs/in2

OVERVIEW

V = Wind Speed

P = Wind Pressure

For example, a wind pressure side load for a 4" side rail with 50 mph wind is calculated as follows: $6.39 * 4"/12" = 2.13 \text{ lbs/ft}$

Ice Loads

Ice is commonly seen building up on the top surface of covers and on the side rails of cable tray and must be taken into account when determining load conditions. The maximum design load added by ice can be calculated with the following formula:

$$LI = (WCT * TI) * DI$$

144

LI = Ice Load (lbs/ft)

WCT = Width of the cable tray (in)

TI = Ice Thickness (in)

DI = Ice Density = 57 lbs/ft³

*Depending on installation location and local building codes, the anticipated ice loads will vary. For a conservative estimate, an ice thickness of 1/2" can be used.

Snow Loads

Snow is measured by both density and thickness, and the additional load applied is dependent on both. The density and thickness of snow varies greatly, and additional design load incorporating snow loads should be determined by local building codes, and done on an individual basis.

SAFETY FACTOR

All loads stated in the Cope Selection Charts have a 1.5 safety factor, in accordance with the NEMA VE-1 Guidelines. A safety factor is the reserve strength, above the actual cable loading, for which a tray system was designed.

Conversion of Safety Factor from 1.5 to 2.0

The loads stated in the Selection Charts have a safety factor of 1.5 per the NEMA VE-1 guidelines. To convert the load carrying capabilities, as listed in these charts, to a 2.0 safety factor, multiply the stated loads by 0.75.

Testing Methods

Loading data stated in the catalog has been derived from actual testing of the tray systems, or by means of structural calculations. These figures were based on Simple Beam calculation, per the NEMA VE-1 guidelines.

When tray is supported as a simple beam, the load causes bending moments all along the beam resulting in deflection, called sag, inducing stress in the beam. The material above the longitudinal center line (neutral axis) is compressed. Material below is stretched and is in tension. The maximum stress in a simple beam is at the center of the span. Failure of cable tray will occur in compression before tension. This is why tray rails often have stiffened top flanges.

A simple beam is present when a single straight section of tray is supported on each end. When a series of straight sections are connected and supported by more than one support it is referred to as a continuous beam. The NEMA VE-1 Standards consider only simple beams for testing purposes, due to the following reasons:

1. It requires maximum properties for a given load and support spacing.
2. It is easiest to approximate by calculation.
3. It represents the most severe or worst case loading.
4. Destruction load capacities can be easily verified.

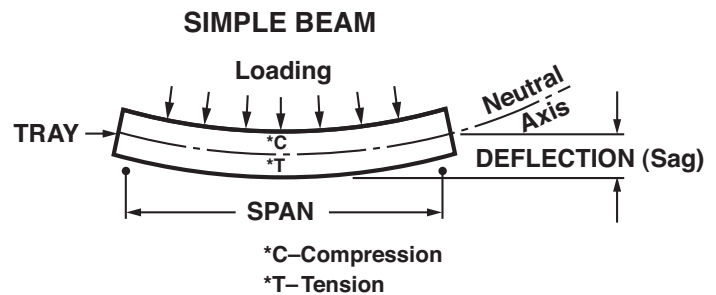

DEFLECTION VS. ECONOMY

Cable tray that meets all performance and dimensional criteria with the safety factor specified without regard for deflection is the most economical tray for the installation. When deflection limitations are imposed, a less economical tray system may result. We recommend that deflection limitations should be imposed in only the most stringent situations. If deflection is a concern, we recommend these maximum limits for the optimum design.

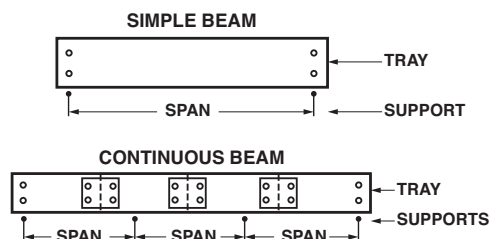

	Simple Beam Span	
	12'	20'
Steel	1/100	1/75
Aluminum	1/75	1/50

CAVITY SIZE - LOAD DEPTH/WIDTH OF TRAY

The size of the cable tray cavity is determined specifically by the electrical requirements and by the specific cables being used to meet those requirements.

Article 392 of the National Electrical Code® lists the specific requirements concerning allowable Cable Fill. It is imperative that the size of the cavity meets the conditions set forth by the NEC®, specifically:

- Types of cables allowed in which type of cable trays
- Requirements for arranging the cables in the trays.

The NEC® breaks down the allowable cable fill into three main categories:

- **Multi-Conductor:** The number of multi-conductor cables rated at 2000 volts or less in cable tray.
- **Single Conductor:** The number of single conductor cables rated at 2000 volts or less in cable tray.
- **MV and MC Cables:** The number of MV & MC cables rated at 2001 volts or over in the cable tray.

Cable fill guidelines set forth by the NEC® are generally based on limiting heat build up in the trays. Where data or communications type cables are being installed, heat is not a critical issue and the allowable fill is determined by the total cross sectional area of the tray cavity:

Total Cross Sectional Area = (Width) x (Load Depth).

LENGTH OF STRAIGHT SECTIONS

Cope Cable Tray is available in 12' and 24' lengths in accordance with the NEMA Standards. It is also available in 10' and 20' lengths in accordance with CSA Standards. Customized lengths are also available upon request.

The following factors need to be considered when specifying the lengths of the tray:

Support Span - The support span should not be greater than the tray length. This ensures that two splice plate connections will not fall within one support span.

Space Constraints - When installing trays in a limited space, as often encountered in commercial applications, 10' and 12' lengths of tray are easier to handle and therefore are better suited for those applications.

Labor Costs - Where trays are being installed in an industrial facility, where space is not as significant an issue, handling 20' and 24' lengths may be more economical. In this instance, half as many tray connections need to be made. Additionally, if the proper tray system is specified, support spans may be lengthened.

RADIUS OF FITTINGS

Cable tray fittings are used to change directions both horizontally and vertically. The standard radii for cable tray fittings are 12", 24", and 36".

The radius of the fittings should be based upon minimum bending radius of the cables. This information can be obtained from the cable manufacturer.

Based on the total number of cables to be placed in the tray, it may be more practical to use the next higher radius.

CABLE TRAY SUPPORT LOCATIONS

Straight Sections

A general rule of thumb is that the splice plates should not fall beyond the ¼ point of the span, or the distance between supports. For example: On a 20' support span the splice plates should not be further than 5' away from the support location.

Under no circumstances should two cable tray splices fall between any pair of supports.

For special applications, mid-span splice plates can be furnished. Please contact the factory.

Fittings

Supports for cable tray elbows are critical. It is important to note that the cable tray will come under its greatest stress when cables are being pulled into the tray. Therefore, proper placement of supports is necessary to insure that the integrity of the tray system is maintained during the cable pulling operation.

The diagrams on page 22 shows the recommended support locations for fittings.

Thermal Expansion and Contraction

It is important to use expansion connectors when installing long runs of cable tray. The number of expansion connectors required will depend on:

- (1) the maximum temperature differential
- (2) the tray material being installed

Cope Expansion Connectors allow 1" of travel. This table illustrates how often expansion splice plates must be used.

Temperature Difference	Dist. Between Expansion Joints		
	Steel	Aluminum	Copper
25°F (14°C)	512' (156m)	260' (79m)	363' (111m)
50°F (28°C)	256' (78m)	130' (40m)	182' (55m)
75°F (42°C)	171' (52m)	87' (27m)	121' (37m)
100°F (56°C)	128' (39m)	65' (20m)	90' (27m)
125°F (70°C)	102' (31m)	52' (16m)	72' (22m)
150°F (83°C)	85' (26m)	43' (13m)	60' (18m)
175°F (97°C)	73' (22m)	37' (11m)	52' (16m)

OVERVIEW

The following table is used to determine the proper gap setting between trays. The metal temperature determines the proper gap setting at the time of installation. Establish maximum and minimum temperatures in summer and winter for the area. Draw a line connecting them. Using the metal temperature at time of installation (C° or F°) draw horizontal to temperature slope and plot straight down to find gap distance at expansion joint.

The following diagram illustrates the proper installation of an expansion system.

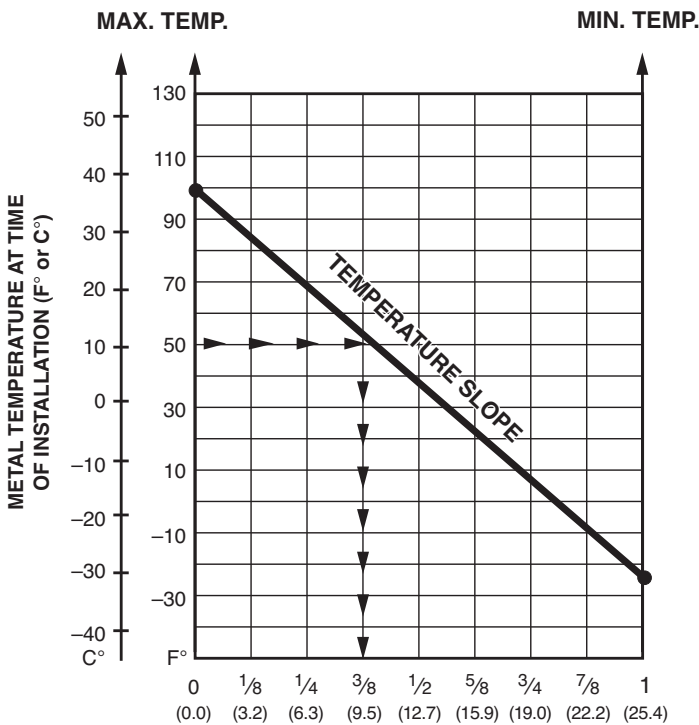

It is important to note that grounding straps are required when expansion connections are made. This will insure proper grounding continuity.

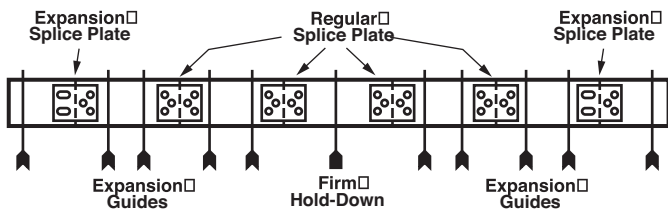

ELECTRICAL GROUNDING

The National Electrical Code®, Article 392-7 allows for Cable Tray to be used as an equipment grounding conductor in commercial and industrial establishments. The following table lists specific ampere ratings and the minimum cross sectional area requirements for each rating.

Atkore International produces trays that meet the National Electrical Code® (ANSI/NFPA 70), and are classified by Underwriters Laboratories, Inc. (UL) as equipment ground conductors. These can be used for any project worldwide except where another standard may take precedence, such as the Canadian Standards Association.

For projects requiring adherence to the Canadian Standards Association (CSA), Cope products as shown in the CSA Selection Charts, pages 34-35, and 142-143 are certified as complying with CSA C22.2 No. 0 and No. 126 and will bear the CSA Mark as shown below.

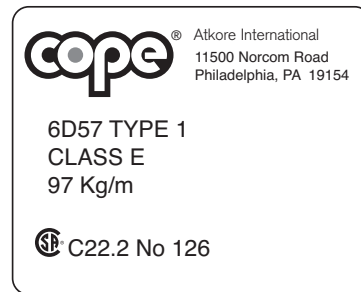

When required, the trays can be installed per the Canadian Electrical Code Parts I and II (CEC). Cope trays and splice plates meet the bonding requirements of the CSA Standards and the CEC.

PAINTING CABLE TRAY

Paintable Grade Cable Tray is available at special request, contact Cope Engineering for additional information or specific product inquiries at 800-882-5543.

SUPPORT LOCATIONS FOR FITTINGS

Max. Fuse Amp Rating Circuit Breaker Amp Trip Setting or Relay Amp Trip Setting for Ground Fault Protection of any Cable Tray Circuit In the Cable Tray system	Minimum Cross Sectional Area of Metal* Steel Cable Trays In2 mm2		Aluminum Cable Trays In2 mm2	
60	0.2	129	0.2	129
100	0.4	258	0.2	129
200	0.7	452	0.2	129
400	1	645	0.4	258
600	1.50**	968	0.4	258
1,000	-	-	0.6	387
1,200	-	-	1	645
1,600	-	-	1.5	968
2,000	-	-	2.00**	1,290

* Total cross sectional area of both side rails for ladder and trof type trays, or the minimum cross sectional area for metal in channel type cable trays or cable trays of one piece construction.

** Steel cable trays shall not be used as equipment grounding conductors for circuits with ground-fault protection above 600 amperes. Aluminum cable trays shall not be used as equipment grounding conductors for circuits with ground-fault protection above 2000 amperes.

Cope CSA steel designs are offered in Type 1 (HDGAF) finish and aluminum with plain finish. Available are ladder, vented, and solid bottom cable Trofs for 3 meter spans and ladder type for 6 meter spans.

The cross-sectional area for each Cope Cable Tray system, straight sections and fittings, can be found on the appropriate Cope Selection charts contained within this publication. In addition all Cope Cable Tray, straight sections and fittings, are supplied with pressure sensitive labels indicating the cross sectional area of both side rails, as required by the (NEC[®]) National Electrical Code[®], Article 392.

Bonding Jumpers / Straps

Cable Tray connections made with Cope's standard rigid splice plates do not exceed .00033 ohms net resistance, and are classified in Underwriters Laboratories Classification Program. These rigid type connections do not require electrical bonding straps. Cope's UL assigned number is "E60627", UL cards will be furnished upon request. Cope is listed in the UL Electrical Construction Directory under code CYNW.

Electrical bonding straps are required where cable trays are joined by connectors which allow for movement, such as vertical adjustable connectors, horizontal adjustable connectors, and expansion connectors.

Proper grounding is also necessary where cable trays run parallel to each other, are stacked upon one another, and in other instances, where tray runs are discontinuous. Further questions concerning grounding issues should be directed to Atkore International.

SUMMARY

You are now ready to select the best Cope Cable Tray system to meet your needs. By now, we hope you've decided to select the system using the NEMA CLASSIFICATION (8A, 12B, 20C, etc.) which makes your work so much easier. Selection is also possible using physical dimensions, performance, or any combination of these data listed in our exclusive NEMA oriented Cope selection charts. As always, should you need additional information, we suggest you contact your nearest Cope Representative or call Atkore International directly.

NEC[®] ARTICLES

Description	2002 and Later Editions	1999 & Prior Editions
Cable Trays	392	318

SUPPORT LOCATIONS FOR FITTINGS

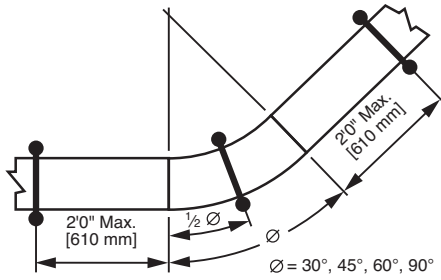

Figure 6-1
HORIZONTAL ELBOWS

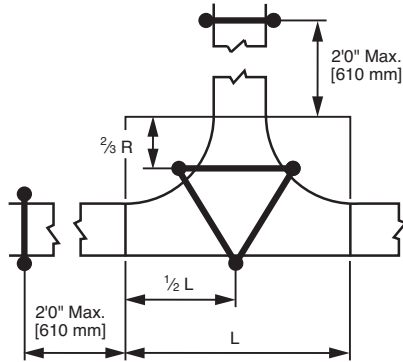

Figure 6-2
HORIZONTAL TEE

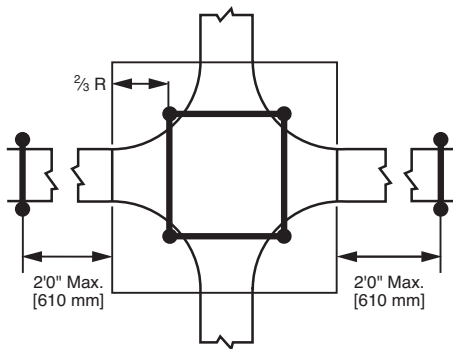

Figure 6-3
HORIZONTAL CROSS

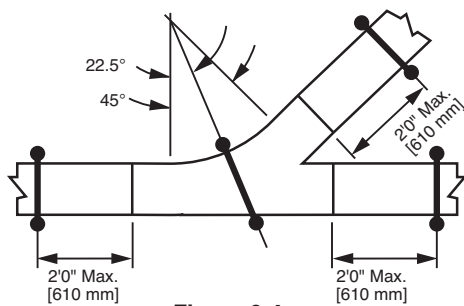

Figure 6-4
HORIZONTAL WYE

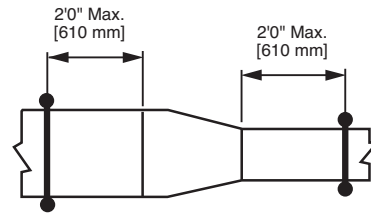

Figure 6-5
STRAIGHT REDUCER

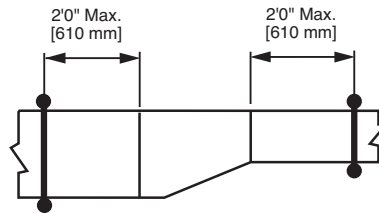

Figure 6-6
OFFSET REDUCER

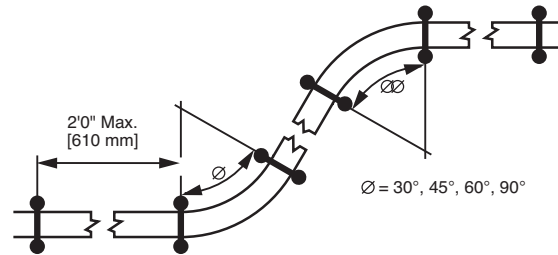

Figure 6-7
VERTICAL ELBOWS

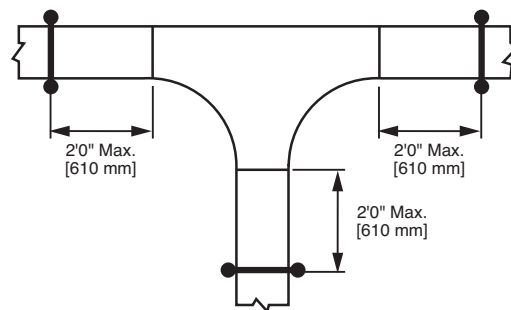

Figure 6-8
VERTICAL TEE

3

LADDER



Cable Ladder System for Power, Control,
Instrumentation Cable & Pneumatic Tubing

LADDER CABLE TRAY SYSTEM

CONTENTS

GENERAL & TECHNICAL INFORMATION

Selection Chart: Cope Ladder - Aluminum	26 - 27
Selection Chart: Cope Ladder - Steel.....	28 - 29
Overview	30 - 31
Ordering Information.....	32
Straight Length.....	33
CSA Ordering Information.....	34
CSA Selection Chart: Aluminum/Steel	35

COPE LADDER FITTINGS

Horizontal Elbows	
90° & 60°	36
45° & 30°	37
Horizontal Tee	38
Horizontal Cross	39
Horizontal Tapped Tee	40 - 41
Horizontal Tapped Cross.....	42 - 43
Left and Right Hand Reducers	44
Straight Reducers	45
Adjustable Elbow	46
45° "Y" Branch	46
Vertical Elbows (Inside and Outside)	
90° & 60°	47
45° & 30°	48
90° Vertical Cable Support Elbow	49
Vertical Tee	49
Electrical Grounding Information	50
Typical Specification.....	50

STRAIGHT LENGTH

Page 33

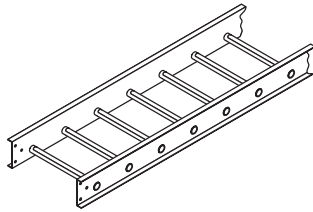

ADJUSTABLE ELBOWS

Page 46

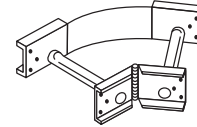

HORIZONTAL ELBOWS

Pages 33-37

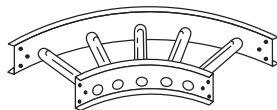

45° "Y" BRANCH

Page 46

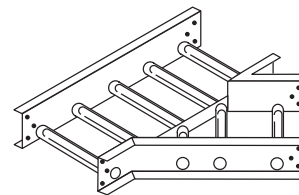

HORIZONTAL TEE & CROSS

Pages 38-39

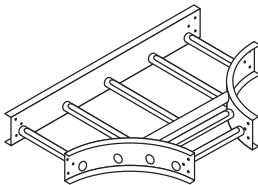

VERTICAL ELBOWS

Pages 47-48

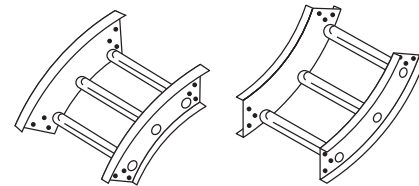

HORIZONTAL TAPPED TEE & CROSS

Pages 40-43

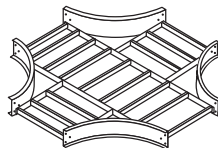

90° VERTICAL CABLE SUPPORT ELBOW

Page 49

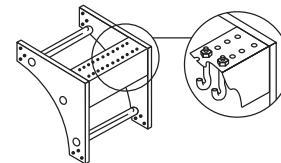

REDUCERS

Pages 44-45

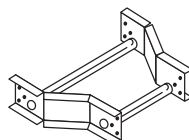

VERTICAL TEE

Page 49

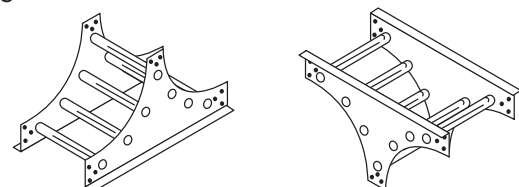

LADDER CABLE TRAY SYSTEM

ALUMINUM TRAY

SELECTION CHART

LOAD AND DEFLECTION DATA FOR ALUMINUM LADDER
Working (Allowable) Load Capacity, Evenly Distributed-Tested per NEMA Standard VE-1
Simple Beam - SAFETY FACTOR 1.5

Cope System Numbers	6 Ft. Span			8 Ft. Span			10 Ft. Span			12 Ft. Span			16 Ft. Span			20 Ft. Span			24 Ft. Span			25 Ft. Span		
	w	d	k	w	d	k	w	d	k	w	d	k	w	d	k	w	d	k	w	d	k	w	d	k
1B38	222	0.35	0.002	125	0.63	0.005	80	0.99	0.012	55	1.42	0.026												
1B48	324	0.33	0.001	173	0.56	0.003	117	0.87	0.007	77	1.26	0.016												
3B58	359	0.22	†	191	0.37	0.002	115	0.55	0.005	75	0.74	0.010												
1B68	416	0.18	†	221	0.31	0.001	133	0.46	0.003	87	0.62	0.007												
3B38	354	0.45	0.001	191	0.76	0.004	117	1.14	0.01	78	1.57	0.020												
1B48	324	0.33	0.001	182	0.59	0.003	117	0.87	0.007	77	1.26	0.016												
3B58	359	0.22	†	191	0.37	0.002	115	0.55	0.005	75	0.74	0.010												
1B68	416	0.18	†	221	0.31	0.001	133	0.46	0.003	87	0.62	0.007												
5B38	448	0.39	†	251	0.69	0.003	161	1.08	0.007	112	1.55	0.014												
3B48	394	0.31	†	222	0.55	0.002	142	0.86	0.006	100	1.24	0.012												
5B58	480	0.24	†	257	0.40	0.002	156	0.60	0.004	102	0.81	0.008												
5B68	540	0.17	†	286	0.29	0.001	172	0.43	0.003	111	0.57	0.005												
5B38				251	0.69	0.003	161	1.08	0.007	112	1.55	0.014	51	2.26	0.044	25	2.75	0.110						
7448				349	0.51	0.001	223	0.80	0.004	155	1.15	0.007	79	1.85	0.023	51	2.89	0.057						
1D58				380	0.49	0.001	222	0.69	0.003	154	1.00	0.006	78	1.61	0.021	50	2.51	0.050						
5D68				316	0.86	0.003	161	1.38	0.009	103	2.16	0.021												
3D38				342	0.72	0.002	219	1.12	0.005	152	1.61	0.011	82	2.74	0.033	52	4.27	0.082						
7448				349	0.51	0.001	223	0.80	0.004	155	1.15	0.007	79	1.85	0.023	51	2.89	0.057						
1D58				380	0.49	0.001	222	0.69	0.003	154	1.00	0.006	78	1.61	0.021	50	2.51	0.050						
5D68				316	0.86	0.003	161	1.38	0.009	103	2.16	0.021												
5D38				444	0.71	0.002	284	0.7	0.002	188	1.53	0.008	106	2.73	0.026	65	4.07	0.063						
3D48				525	0.55	0.001	336	0.86	0.003	233	1.24	0.005	119	2.01	0.017	76	3.14	0.041						
5D58										229	1.00	0.004	116	1.60	0.014	75	2.5	0.033						
5D68										316	0.86	0.003	161	1.38	0.009	103	2.16	0.021						
3D38										152	1.61	0.011	82	2.74	0.033	52	4.27	0.082						
7448										155	1.15	0.007	79	1.85	0.023	51	2.89	0.057						
1D58										154	1.00	0.006	78	1.61	0.021	50	2.51	0.050						
5D68										316	0.86	0.003	161	1.38	0.009	103	2.16	0.021						
3D48										233	1.24	0.005	119	2.01	0.017	76	3.14	0.041						
5D58										229	1.00	0.004	116	1.60	0.014	75	2.5	0.033						
5D68										316	0.86	0.003	161	1.38	0.009	103	2.16	0.021						
5E38										298	1.79	0.006	161	3.07	0.019	103	4.79	0.047						
5D48										290	1.35	0.005	156	2.30	0.015	100	3.59	0.036						
7D58							404	0.76	0.002	281	1.09	0.004	158	1.94	0.012	101	3.02	0.030						
5D68										316	0.86	0.003	161	1.38	0.009	103	2.16	0.021						
3658										215	0.92	0.004	121	1.63	0.013	77	2.55	0.033						
1E68										221	0.90	0.004	119	1.53	0.013	76	2.39	0.032						
9D58										412	1.22	0.003	214	2.00	0.009	131	3.01	0.023	68	3.23	0.048			
7G58										451	1.20	0.003	253	2.14	0.008	162	3.35	0.020	112	4.79	0.043	104	5.24	0.05

Note: To convert 1.5 safety factor to 2.0 multiply w, d, k by 0.75.

W=Pounds per linear foot
Metric: for kg/m multiply w by 1.48
d=Deflection (inches)
k= Deflection (in.) for each pound of load
†= Denotes k is less than .001 inch

NEMA CLASS, PHYSICAL AND STRUCTURAL PROPERTIES

NEMA Standard VE-1 Load/ Span Class	Cope System Number	Cope Systems Certified By CSA (See pg. 3-9)	Actual Load Depth		Side Rail Height		Flange Width (in.)	Sect. Mod. of 2 Rails Sx (in. ³)	Moment of Inertia for 2 Rails Ix (in. ⁴)	Min X-Sect. Area of 2 Rails per NEC 392.7 (in. ²)
8A-12A 50 lb./ft. 12' span	1B38	1B38	3"	(76mm)	4¼"	(108mm)	⅜"	0.898	1.822	0.60
	1B48	1B48	4"	(102mm)	5½"	(133mm)	⅜"	1.142	2.872	0.60
	3B58	—	5"	(127mm)	6¼"	(159mm)	⅜"	1.614	4.720	1.00
	1B68	—	6"	(152mm)	7¼"	(184mm)	⅜"	1.874	6.568	1.00
12B 75 lb./ft. 12' span	3B38	—	3"	(76mm)	4¼"	(108mm)	⅜"	1.148	2.270	0.60
	1B48	1B48	4"	(102mm)	5½"	(133mm)	⅜"	1.142	2.872	0.60
	3B58	—	5"	(127mm)	6¼"	(159mm)	⅜"	1.614	4.720	1.00
	1B68	—	6"	(152mm)	7¼"	(184mm)	⅜"	1.874	6.568	1.00
12C 100 lb./ft 12' span	5B38	—	3"	(76mm)	4¼"	(108mm)	⅜"	1.646	3.350	1.00
	3B48	—	4"	(102mm)	5½"	(133mm)	⅜"	1.522	3.734	1.00
	5B58	—	5"	(127mm)	6¼"	(159mm)	⅜"	1.944	5.866	1.00
	5B68	—	6"	(152mm)	7¼"	(184mm)	⅜"	2.576	9.032	1.00
16A 50 lb./ft. 16' span	5B38	—	3"	(76mm)	4¼"	(108mm)	⅜"	1.646	3.350	1.00
	7448	7448	4"	(102mm)	5½"	(133mm)	¼"	2.396	6.292	1.50
	1D58	1D58	5"	(127mm)	6¼"	(159mm)	¼"	2.378	7.202	1.00
	5D68	5D68	6"	(152mm)	7¼"	(184mm)	¼"	4.874	17.188	2.00
16B 75 lb./ft. 16' span	3D38	3D38	3"	(76mm)	4¼"	(108mm)	¼"	2.242	4.406	1.50
	7448	7448	4"	(102mm)	5½"	(133mm)	¼"	2.396	6.292	1.50
	1D58	1D58	5"	(127mm)	6¼"	(159mm)	¼"	2.378	7.202	1.00
	5D68	5D68	6"	(152mm)	7¼"	(184mm)	¼"	4.874	17.188	2.00
16C 100 lb./ft. 16' span	5D38	5D38	3"	(76mm)	4¼"	(108mm)	¼"	2.782	5.738	1.50
	3D48	3D48	4"	(102mm)	5½"	(133mm)	¼"	3.434	8.746	2.00
	5D58	5D58	5"	(127mm)	6¼"	(159mm)	¼"	3.542	10.748	2.00
	5D68	5D68	6"	(152mm)	7¼"	(184mm)	¼"	4.874	17.188	2.00
20A 50 lb./ft. 20' span	3D38	3D38	3"	(76mm)	4¼"	(108mm)	¼"	2.242	4.406	1.50
	7448	7448	4"	(102mm)	5½"	(133mm)	¼"	2.396	6.292	1.50
	1D58	—	5"	(127mm)	6¼"	(159mm)	¼"	2.378	7.202	1.00
	5D68	5D68	6"	(152mm)	7¼"	(184mm)	¼"	4.874	17.188	2.00
20B 75 lb./ft. 20' span	3D48	—	4"	(102mm)	5½"	(133mm)	¼"	3.434	8.746	2.00
	5D58	5D58	5"	(127mm)	6¼"	(159mm)	¼"	3.542	10.748	2.00
	5D68	5D68	6"	(152mm)	7¼"	(184mm)	¼"	4.874	17.188	2.00
20C 100 lb./ft. 20' span	5E38	—	3"	(76mm)	4¼"	(108mm)	½"	3.716	7.758	2.00
	5D48	—	4"	(102mm)	5½"	(133mm)	¼"	3.910	10.020	2.00
	7D58	7D58	5"	(127mm)	6¼"	(159mm)	¼"	4.186	12.024	2.00
	5D68	5D68	6"	(152mm)	7¼"	(184mm)	¼"	4.874	17.188	2.00
OTHER ECONOMICAL SYSTEMS AVAILABLE										
	3658	3658	5"	(127mm)	6¼"	(159mm)	⅜"	3.490	10.906	1.50
	1E68	—	6"	(152mm)	7¼"	(184mm)	½"	3.252	11.452	1.50
EXTRA HEAVY DUTY - VERY LONG SPAN TRAYS- 6", 9" OR 12" RUNG SPACING										
	9D58	—	5"	(127mm)	6¼"	(159mm)	¼"	5.130	15.700	2.00
	7G58	—	5"	(127mm)	6¼"	(159mm)	2"	5.804	17.456	2.00

Note: Special Applications Available. Please Contact Factory.

LADDER CABLE TRAY SYSTEM

STEEL TRAY

SELECTION CHART

NEMA CLASS, PHYSICAL AND STRUCTURAL PROPERTIES

NEMA Standard VE-1 Class NEMA Load/Span	Mill Galv. System Number	HDGAF System Number	Type 304 SS System Number	Cope Systems Certified By CSA	Actual Load Depth	Side Rail Height	Flange Width (in.)	Section Modulus of 2 Rails Sx (in.3)	Moment of Inertia for 2 Rails Ix (in.4)	Min. X-Sect. Area of 2 Rails per NEC 392-7 (in.2)
8A-12B 75 lb./ft. 12' span	8B36	6237	8B3T	8B36	3" (76mm)	4 1/4" (108mm)	13/16"	0.678	1.37	0.4
	8246	6247	824T	—	4" (102mm)	5 1/4" (133mm)	13/16"	0.816	2.14	0.4
	8256	6257	825T	—	5" (127mm)	6 1/4" (159mm)	13/16"	1.072	3.35	0.7
	8B66	6B67	8B6T	8B66	6" (152mm)	7 1/4" (184mm)	13/16"	1.574	5.52	0.7
12C 100 lb./ft. 12' span	6B36	6B37	6B3T	—	3" (76mm)	4 1/4" (108mm)	13/16"	0.834	1.69	0.7
	8B46	6B47	8B4T	—	4" (102mm)	5 1/4" (133mm)	13/16"	0.924	2.32	0.4
	6256	6257	625T	—	5" (127mm)	6 1/4" (159mm)	13/16"	1.330	4.16	0.7
	8B66	6267	8B6T	8B66	6" (152mm)	7 1/4" (184mm)	13/16"	1.574	5.52	0.7
16A 50 lb./ft. 16' span	8D36	6D37	8D3T	—	3" (76mm)	4 1/4" (108mm)	1 1/4"	0.852	1.74	0.4
	8D46	6447	8D4T	—	4" (102mm)	5 1/4" (133mm)	1 1/4"	1.146	2.89	0.7
	8456	6457	845T	—	5" (127mm)	6 1/4" (159mm)	1 1/4"	1.330	4.16	0.7
	6466	6467	646T	6466/7	6" (152mm)	7 1/4" (184mm)	1 1/4"	2.062	7.48	1.0
16B 75 lb./ft. 16' span	6D36	6D37	6D3T	—	3" (76mm)	4 1/4" (108mm)	1 1/4"	1.056	2.15	0.7
	8D46	6447	8D4T	—	4" (102mm)	5 1/4" (133mm)	1 1/4"	1.146	2.89	0.7
	6456	6457	645T	6456/7	5" (127mm)	6 1/4" (159mm)	1 1/4"	1.652	5.16	1.0
	6466	6467	646T	6466/7	6" (152mm)	7 1/4" (184mm)	1 1/4"	2.062	7.48	1.0
16C 100 lb./ft. 16' span	4D36	4D37	4D3T	—	3" (76mm)	4 1/4" (108mm)	1 1/4"	1.298	2.65	1.0
	6446	6447	644T	—	4" (102mm)	5 1/4" (133mm)	1 1/4"	1.280	3.36	0.7
	6456	6457	645T	6456/7	5" (127mm)	6 1/4" (159mm)	1 1/4"	1.652	5.16	1.0
	8D66	6D67	8D6T	—	6" (152mm)	7 1/4" (184mm)	1 1/4"	1.814	6.37	0.7
20A 50 lb./ft. 20' span	6D36	6D37	6D3T	—	3" (76mm)	4 1/4" (108mm)	1 1/4"	1.056	2.15	0.7
	6446	6447	644T	—	4" (102mm)	5 1/4" (133mm)	1 1/4"	1.280	3.36	0.7
	6456	6457	645T	6456/7	5" (127mm)	6 1/4" (159mm)	1 1/4"	1.652	5.16	1.0
	6466	6467	646T	6466/7	6" (152mm)	7 1/4" (184mm)	1 1/4"	2.062	7.48	1.0
20B 75 lb./ft. 20' span	2D36	2D37	2D3T	—	3" (76mm)	4 1/4" (108mm)	1 1/4"	1.758	3.60	1.0
	4D46	4D47	4D4T	—	4" (102mm)	5 1/4" (133mm)	1 1/4"	1.744	4.42	1.0
	6D56	6D57	6D5T	6D56/7	5" (127mm)	6 1/4" (159mm)	1 1/4"	1.814	5.49	1.0
	6D66	6D67	6D6T	6D66/7	6" (152mm)	7 1/4" (184mm)	1 1/4"	2.246	7.90	1.0
20C 100 lb./ft. 20' span	2D46	2D47	2D4T	—	4" (102mm)	5 1/4" (133mm)	1 1/4"	2.370	6.03	1.5
	4D56	4D57	4D5T	4D56	5" (127mm)	6 1/4" (159mm)	1 1/4"	2.240	6.78	1.0
	4466	4467	446T	—	6" (152mm)	7 1/4" (184mm)	1 1/4"	2.556	9.26	1.0
OTHER ECONOMICAL SYSTEMS AVAILABLE										
	4B36	4B37	4B3T	—	3" (76mm)	4 1/4" (108mm)	13/16"	1.024	2.08	0.7
	6B46	6B47	6B4T	—	4" (102mm)	5 1/4" (133mm)	13/16"	1.140	2.87	0.7
	4B46	4B47	4B4T	—	4" (102mm)	5 1/4" (133mm)	13/16"	1.402	3.54	1.0
EXTRA HEAVY DUTY - VERY LONG SPAN TRAYS - 6", 9" OR 12" RUNG SPACING										
	2D56	2D57	2D5T	—	5" (127mm)	6 1/4" (159mm)	1 1/4"	3.052	9.27	1.5
	11D56	11D57	11D5T	—	5" (127mm)	6 1/4" (159mm)	1 1/4"	3.536	10.63	1.5

LOAD AND DEFLECTION DATA FOR STEEL LADDER
Working (Allowable) Load Capacity, Evenly Distributed-Tested per NEMA Standard VE-1,
Simple Beam - SAFETY FACTOR 1.5

Cope System Numbers	6 Ft. Span			8 Ft. Span			10 Ft. Span			12 Ft. Span			16 Ft. Span			20 Ft. Span			24 Ft. Span			25 Ft. Span		
	w	d	k	w	d	k	w	d	k	w	d	k	w	d	k	w	d	k	w	d	k	w	d	k
8B36/6237/8B3T	360	0.26	†	198	0.46	0.002	124	0.70	0.01	84	1.0	0.01												
8246/6247/824T	383	0.18	†	210	0.31	0.001	127	0.46	0.00	83	0.6	0.01												
8256/6257/825T	357	0.11	†	194	0.18	†	119	0.28	0.00	79	0.4	0.01												
8B66/6B67/8B6T	680	0.12	†	328	0.19	†	182	0.26	0.00	107	0.3	0.00												
6B36/6B37/6B3T	453	0.27	†	249	0.47	0.002	156	0.71	0.01	106	1.0	0.01												
8B46/6B47/8B4T	456	0.20	†	244	0.33	0.001	152	0.51	0.00	103	0.7	0.01												
6256/6257/625T	460	0.11	†	250	0.19	†	154	0.29	0.00	103	0.4	0.00												
8B66/6267/8B6T	680	0.12	†	328	0.19	†	182	0.26	0.00	107	0.3	0.00												
8D36/6D37/8D3T				290	0.53	0.002	182	0.81	0.00	126	1.2	0.01	65	1.9	0.029									
8D46/6447/8D4T				382	0.42	0.001	245	0.66	0.00	170	0.9	0.01	86	1.5	0.018									
8456/6457/845T				268	0.20	†	166	0.31	0.00	111	0.4	0.00	58	0.7	0.012									
6466/6467/646T				372	0.20	†	238	0.24	0.00	178	0.4	0.00	93	0.6	0.007									
6D36/6D37/6D3T				381	0.56	0.001	244	0.88	0.00	169	1.3	0.01	88	2.1	0.024									
8D46/6447/8D4T				382	0.42	0.001	245	0.66	0.00	170	0.9	0.01	86	1.5	0.018									
6456/6457/645T				574	0.35	†	367	0.55	0.00	245	0.8	0.00	123	1.2	0.01									
6466/6467/646T				372	0.20	†	238	0.24	0.00	178	0.4	0.00	93	0.6	0.007									
4D36/4D37/4D3T				487	0.58	0.001	312	0.91	0.00	216	1.3	0.01	113	2.2	0.019									
6446/6447/644T				444	0.42	†	273	0.63	0.00	186	0.9	0.01	100	1.5	0.015									
6456/6457/645T				574	0.35	†	367	0.55	0.00	245	0.8	0.00	123	1.2	0.01									
8D66/6D67/8D6T				504	0.25	†	306	0.37	0.00	202	0.5	0.00	101	0.8	0.008									
6D36/6D37/6D3T										169	1.3	0.01	88	2.1	0.024	52	3.0	0.057						
6446/6447/644T										186	0.9	0.01	100	1.5	0.015	53	1.9	0.037						
6456/6457/645T										245	0.8	0.00	123	1.2	0.01	66	1.6	0.024						
6466/6467/646T										178	0.4	0.00	93	0.6	0.007	55	0.9	0.017						
2D36/2D37/2D3T										304	1.4	0.00	159	2.2	0.014	94	3.2	0.034						
4D46/4D47/4D4T										280	1.0	0.00	145	1.7	0.012	85	2.4	0.028						
6D56/6D57/6D5T										269	0.8	0.00	139	1.3	0.009	81	1.8	0.022						
6D66/6D67/6D6T										291	0.6	0.00	148	1.0	0.006	85	1.3	0.016						
2D46/2D47/2D4T										395	1.1	0.00	206	1.7	0.008	121	2.5	0.021						
4D56/4D57/4D5T										296	0.8	0.00	152	1.3	0.008	105	1.9	0.018						
4466/4467/446T										379	0.7	0.00	191	1.1	0.005	102	1.4	0.013						
4B36/4B37/4B3T	569	0.28	†	313	0.48	0.002	196	0.73	0.00	133	1.0	0.01	74	1.8	0.025									
6B46/6B47/6B4T	591	0.21	†	325	0.36	0.001	203	0.55	0.00	137	0.8	0.01	77	1.4	0.019									
4B46/4B47/4B4T	779	0.22	†	428	0.38	†	268	0.59	0.00	182	0.8	0.01	102	1.5	0.016	65	2.3	0.39						
2D56/2D57/2D5T										490	0.9	0.00	254	1.4	0.006	149	2.0	0.013	79	1.91	0.024	73	2.38	0.033
11D56/11D57/11D5T										434	0.7	†	244	1.2	0.005	156	1.8	0.012	108	2.62	0.024	100	2.85	0.029

Note: To convert 1.5 safety factor to 2.0 multiply w, d, k by 0.75.

W=Pounds per linear foot

Metric: for kg/m multiply w by 1.48

d=Deflection (inches)

k= Deflection (in.) for each pound of load

†= Denotes k is less than .001 inch

LADDER CABLE TRAY SYSTEM

OVERVIEW

COPE SWAGE LADDER is a structure consisting of two side rails, connected by individual rungs and is manufactured in accordance with NEMA Standard #VE-1. Cope rungs are fastened to the side members by an exclusive swaging process. This assembly method insures a superior mechanical and electrical connection.

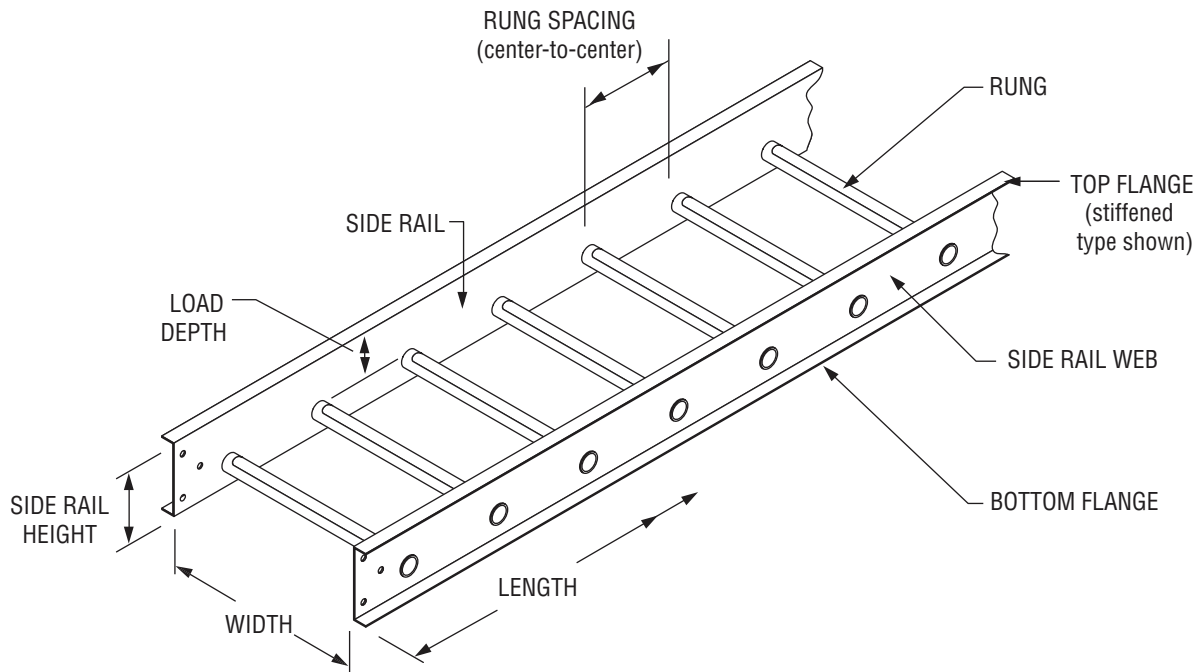

Side Members - Cope side members are designed with top and bottom flanges turned outward. This simplifies fastening the cable tray to the supports. Cable tray with outward facing flanges allows complete access within the cable loading area and eliminates the possibility of cable damage from sharp edges within the cable area. The return on the top flange strengthens the side member and allows cable to be smoothly dropped over the side.

Rung - Cope ladder rungs are 1.00" diameter tubing flattened on top to provide a cable bearing surface. This construction allows cable to drop out anywhere without contacting a sharp edge.

Rung Spacing - The interval at which rungs are swaged to the side member. This is measured from centerline of rung to centerline of rung. Cope manufactures straight lengths with four standard rung spacings; 6", 9", 12", and 18". Rung spacing selected is generally determined by size and type of cable being supported. When in doubt, 9" rung spacing is a generally accepted compromise.

Length - The longitudinal dimensions of standard Cope Cable Ladder are 10', 12', 20' or 24'.

Width - The transverse dimensions of Cope Cable Ladder are measured inside, (from side member web to side member web), and are furnished in seven standard widths: 6", 9", 12", 18", 24", 30", or 36".

Overall Width - Overall ladder width is equal to the inside or nominal width plus the width of side member flanges.

Load Depth - Measured from top surface of rung to top of side member. This is not to be confused with overall height. Cope manufactures four loading depths: 3", 4", 5", and 6" in accordance with NEMA Standard VE-1. All Cope part numbers refer to the load depth of the tray.

Overall Height - Cope overall height is equal to the loading depth plus 1- $\frac{1}{4}$ ".

Fittings - For changing direction horizontally and vertically, Cope manufactures elbows, tees and crosses in all widths and loading depths. Fittings are available in three standard radii; 12", 24", and 36". Cope maintains a nominal 9" rung spacing through the centerline of all fittings.

OVERVIEW

COPE CABLE LADDER FEATURES IMPORTANT INDUSTRY-LEADING FEATURES:

1. Universal Curvilinear Splice Plate System

The splice plates for rigid connections have a slight curve so they can be used on straight sections or fittings. Tightening of the fastener pulls the plate flush with the side rail. The fasteners are snug and the joint is superior structurally and electrically. Even when tightened by hand, there is pressure on the fastener to hold it securely.

Note: Heavy Duty, Mid Span Splice Plates available upon request.

2. Zero Tangent Fittings

Tangent as referred to on cable tray fittings is the straight at the end of the curve to accommodate a flat splice plate. Zero Tangent Fittings facilitates installation when parallel cable trays must be located at minimum distances from each other, such as motor control centers and switch gear centers. COPE ZERO TANGENT FITTINGS CAN SAVE UP TO A MINIMUM OF 6" PER ROW OF TRAY.

3. Cope's Swaged Rung Cable Ladder System Process

The heart of the Cope design is the tubular rung and its connection to the side rail by cold swaging... a process where special machinery compresses and locks the tubular rung material around both the inside and outside of the cable tray side rails. This connection is made without the use of heat, which can potentially disturb the molecular structure of the metal and weaken it.

The tubular rung is flattened during the swaging process to ensure a proper cable bearing surface.

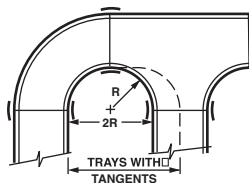

Testing - The superior strength of the swaged ladder tray system has been verified in independent testing conducted by the Pittsburgh Testing Laboratory.

Pullout loads of 2500 lbs. were reached. Other tests show the same type rungs, when welded, had a 35% lower pullout load. The strength of the swage also maintains the 90° relationship of the rungs to

the side rail. The tubular rungs, which are very stiff, transmit the cable loads to the side rails resulting in much less deflection than in a similar system with welded rungs.

For a copy of the independent test results, please contact the factory.

Swage Advantages -

Cold swaging allows for the side rails to be turned outward, simplifying cable installation, and provides 100% access to the cables. The cold swaging yields the most rigid tray system in the industry.

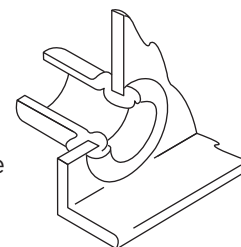

The swaged rung connection resists stresses in all directions; up or down, side to side, or in and out. The swaged ladder also resists the camber and warping effects encountered in a typical welded system.

The increased rigidity means that a 24' section of tray can be lifted on one end with little or no twisting or bending of the tray section. This rigid construction makes the trays safer for field personnel to handle and reduces shipping damage.

Electrical Properties - Electrically, the 106 tons of pressure in the swaging process virtually eliminates the interstices and a homogenous electrical path results:

Resistance of Cope Aluminum Swaged Tray: 31 microhms

Resistance of Cope Steel Swaged Tray: 37.3 microhms

Resistance of Popular Aluminum Welded Tray: 101 microhms

Conclusion - Cold swaging yields a very strong, efficient and aesthetically pleasing system that has stood the test of time and offers installation savings due to its ease of handling.

Ordering Information:

See Page 48 for Electrical Grounding Chart

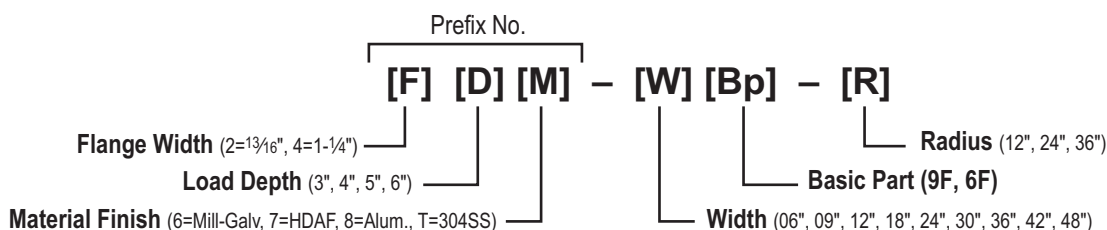

LADDER CABLE TRAY SYSTEM

PART NUMBERING SYSTEM:

Please pay careful attention to the part numbering structure. Example: Catalog No. 1B48-06SL-12-09 is a 4" load depth aluminum ladder with a 13/16" flange, 6 inches wide, straight length 12 feet long, rungs on 9" centers. Please make sure to use the system numbers from pages 26 through 29 when ordering.

SYSTEM NUMBER (STRAIGHT SECTION ONLY) -

The first four digits make up the system number which identifies the structural, dimensional and material characteristics of the straight length. It is made up of the side rail digits indicating the side rail thickness and flange width, the load depth (inside, in inches), and material finish (galvanized, aluminum or coated).

PREFIX NUMBER (FITTINGS ONLY) - Fittings are ordered using the 3-digit prefix number given in the charts on the fitting pages. Fittings do not have stiffened upper flanges.

WIDTH - Identifies the inside width of the tray in inches. **Note:** Sizes 42" and 48" are not recognized by NEMA

BASIC PART NUMBER - Identifies the straight length, fitting or accessory.

SECONDARY DIMENSION NUMBER - Identifies the length of a straight section in feet, the radius of a fitting in inches, or the second width of a reducer in inches.

RUNG SPACING - Identifies the center-to-center distance between rungs on straight length. Nominal 9" (229mm) rung spacing maintained through center line of all fittings.

FITTING DESCRIPTIONS

Width (in.) ***	Basic Part Number	Length	Rung Spacing
-06=6" (152mm)	SL (Straight Len.)	- 12' (3.7m)	06=6" (152mm)
-09=9" (229mm)	9F (90° Horiz. El.)	- 24' (7.3m)	09=9" (229mm)
-12=12" (305mm)	6F (60° Horiz. El.)	- 10' (3m, CSA)	12=12" (305mm)
-18=18" (457mm)	4F (45° Horiz. El.)	- 20' (6m, CSA)	18=18" (457mm)
-24=24" (610mm)	3F (30° Horiz. El.)		
-30=30" (762mm)	90 (90° Out. Vert. El.)		
-36=36" (914mm)	60 (60° Out. Vert. El.)		
-42=42" (1067mm)	40 (45° Out. Vert. El.)		
-48=48" (1219mm)	30 (30° Out. Vert. El.)		
			Radius (in.)
			-12=12" (205mm)
			-24=24" (610mm)
			-36=36" (914mm)

Thickness Steel (Ga.)	Flange Width	Load Depth	Material/ Finish
8 - 18 ga.	2 - 13/16" (21mm)	3" (76mm)	6 - Mill-Galv.
6 - 16 ga.	4 - 1 1/4" (32mm)	4" (102mm)	7 - HDGAF
4 - 14 ga.	5 - 1 1/2" (38mm)	5" (127mm)	8 - Aluminum
2 - 12 ga.	6 - 1 3/4" (45mm)	6" (152mm)	T - 304SS
11 - 11 ga.	7 - 2" (51mm)		
Thickness Alum (in.)			
1 - Thinner	B - 13/16" (21mm)		
3 -	D - 1 1/4" (32mm)		
5 - **	E - 1 1/2" (38mm)		
7 -	F - 1 3/4" (45mm)		
9 - Thicker	G - 2" (51mm)		

**Alum. extruded side rails are individually engineered to loads and spans

*** Contact factory for 42" and 48" width tray (not NEMA Standard)

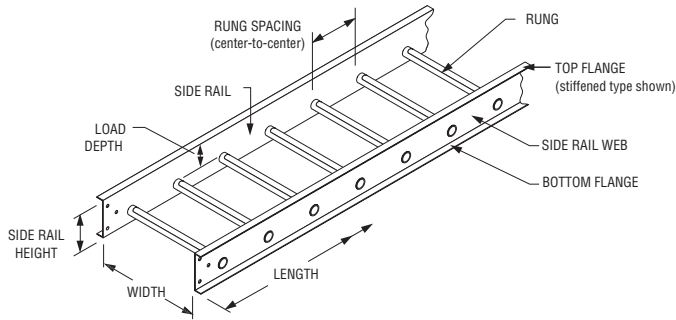

COPE LADDER is manufactured in 10' (CSA), 12', 20' (CSA), and 24' lengths; 6", 9", 12", 18", 24", 30", and 36" widths; and, 3", 4", 5", and 6" load depths. Rungs are 1" diameter tubes with a $\frac{7}{8}$ " flattened cable support surface. 6", 9", 12", and 18" rung spacings are available. Fittings have nominal 9" rung spacing through center line. Dimensions given are inside. For overall widths add two flange widths of the system selected (see Selection Charts). Some systems have stiffened upper (top) flanges to obtain rigidity required (see Selection Charts).

Rungs are assembled to side rails by Cope's exclusive cold swaging process. Outward facing flanges allow full unobstructed access to contents of tray in width and depth.

Materials: Aluminum, Hot Dip Mill-Galvanized (pre galvanized) to ASTM A-653, Hot Dip Galvanized After Fabrication (HDGAF) to ASTM A-123, Stainless Steel (Type 304 and 316). Sufficient connectors are supplied to assemble straight sections and fittings for each order. Connectors for field cuts to be ordered separately (see Connectors).

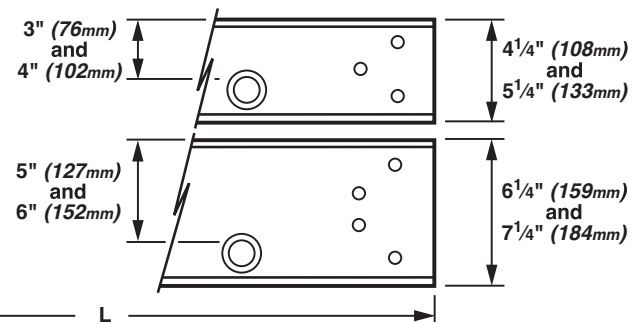
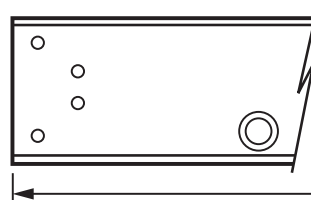
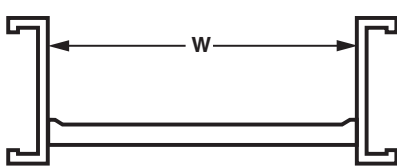

CATALOG NUMBER

System	Width	Basic No.	Length	Rung Spacing
See Pages 25-29	-06=6" (152mm)	SL	NEMA	-06=6" (152mm)
	-09=9" (229mm)		12' (3.7m)*	-09=9" (229mm)
	-12=12" (305mm)		24' (7.3m)*	-12=12" (305mm)
	-18=18" (457mm)		10' (3m)*	
	-24=24" (610mm)		CSA	-18=18" (457mm)
	-30=30" (762mm)		20' (6m)*	
	-36=36" (914mm)		-10' (3m)	
	-42=42"*** (1067mm)		-20' (6m)	
	-48=48"*** (1219mm)			

* 10' & 12' all NEMA Classes, 20' & 24' NEMA Classes 16A, 16B, 16C, 20A, 20B, 20C.

** not NEMA standard width

Example: Catalog No. 1B48-06SL-12-09 is a 4-inch load depth aluminum ladder with a $\frac{1}{16}$ " flange, 6 inches wide, straight length 12 feet long, runs on 9" centers.

CONVERSION TABLE

	English								CSA			
English	6"	9"	12"	18"	24"	30"	36"	12'	24'	10'	20'	
Metric (mm)	152	229	305	457	610	762	914	3.7m	7.3m	3m	6m	

MATERIAL & FINISH SPECIFICATIONS (Ladder Cable Tray)

	Pre-Galvanized Steel	Hot-Dip Galvanized after Fabrication ASTM A-123	Aluminum	Type 304 Stainless Steel
Siderails	ASTM A-653-G90 CS (18 & 16 Gage) ASTM A-653-G90 CS (14 & 12 Gage)	ASTM A-1008 (18 & 16 Gage) ASTM A-1011 (14 & 12 Gage)	AA-6063-T6 Extruded	ASTM A-240; Type 304
Rungs	ASTM A-653-G90 CS	ASTM A-1008	AA-6063-T6 Extruded* AA-6063-T832 Extruded* AA-6063-T52 Extruded*	ASTM A-269; Type 304
Splice Plate Finish	ASTM A-1011 ASTM A-591 Class C	ASTM A-1011 ASTM A-123 Grade 65	AA-5052-H34	ASTM A-240; Type 304 2B Finish (Typical)
Connector Bolts	SAE J429 Grade 1 (ASTM A-307 Grade A)	SAE J429 Grade 1 (ASTM A-307 Grade A)	SAE J429 Grade 1 (ASTM A-307 Grade A)	AISI Type 304 Stainless Steel
Bolt Plating	ASTM B-633.0002" Zinc	ASTM B-633.0002" Zinc	ASTM B-633.0002" Zinc	
Covers	ASTM A-653-G90 CQ	ASTM A-653-G90 CQ	AA-3003 H14 or 3150 H14	ASTM A-240; Type 304

LADDER CABLE TRAY SYSTEM

CSA ORDERING INFORMATION

COPE CSA STANDARDS C22-2 CABLE TROF LADDER TYPE

HOW TO ORDER: Explanation of Cope's Canadian Standards cable tray catalog numbers is described below. Use the system numbers given in selection charts for straight sections, or the fitting prefix numbers given in fitting tables. Be sure to follow system number or the fitting prefix with the item "description" number. The list below gives the CSA certified item carrying the CSA label.



STRAIGHT LENGTH

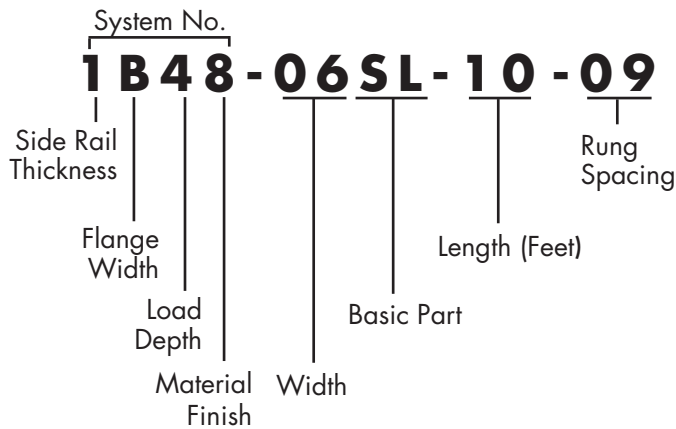

SYSTEM NUMBER (STRAIGHT SECTION ONLY) -

The first four digits make up the system number which identifies the structural, dimensional, and material characteristics of the straight length. It is made up of the side rail digits indicating the side rail thickness and flange width, the load depth (inside, in inches), and material finish (galvanized, aluminum or coated).

PREFIX NUMBER (FITTINGS ONLY) - Fittings are ordered using the 3-digit prefix number given in the charts on the fitting pages. Fittings do not have stiffened upper flanges.

WIDTH - Identifies the inside width of the tray in inches.

BASIC PART NUMBER - Identifies the straight length, fitting, or accessory.

Thickness Steel (Ga.)	Flange Width	Load Depth	Material/ Finish
8 - 18 ga.	2 - 13/16" (21mm)	3" (76mm)	7 - HDGAF
6 - 16 ga.	4 - 1 1/4" (32mm)	4" (102mm)	CSA Class 1
4 - 14 ga.	6 - 1 3/4" (45mm)	5" (127mm)	8 - Aluminum
	*B - 13/16" (21mm)	6" (152mm)	Plain Finish
Thickness Alum (in.)	*D - 1 3/4" (32mm)		
1 - Thinner			
3 -			
5 - **			
7 - Thicker			

*Stiffened Upper Flange

**Alum. extruded side rails are individually engineered to loads and spans

FITTINGS

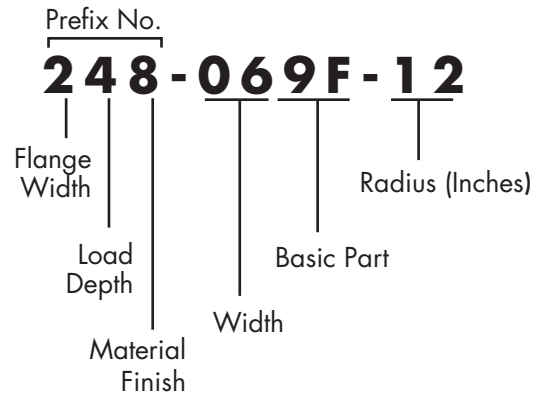

SECONDARY DIMENSION NUMBER - Identifies the length of a straight section in feet, the radius of a fitting in inches, or the second width of a reducer in inches.

RUNG SPACING - Identifies the center-to-center distance between rungs on straight length. Nominal 9" (229mm) rung spacing maintained through center line of all fittings.

DESCRIPTIONS

Width (in.) ***	Basic Part Number	Length	Rung Spacing
-06=6" (152mm)	SL (Straight Len.)	- 12' (3.7m)	06=6" (152mm)
-09=9" (229mm)	9F (90° Horiz. El.)	- 24' (7.3m)	09=9" (229mm)
-12=12" (305mm)	6F (60° Horiz. El.)	- 10' (3m, CSA)	12=12" (305mm)
-18=18" (457mm)	4F (45° Horiz. El.)	- 20' (6m, CSA)	18=18" (457mm)
-24=24" (610mm)	3F (30° Horiz. El.)		
-30=30" (762mm)	90 (90° Out. Vert. El.)		
-36=36" (914mm)	60 (60° Out. Vert. El.)		
-42=42" (1067mm)	40 (45° Out. Vert. El.)		
-48=48" (1219mm)	30 (30° Out. Vert. El.)		
	9I (90° In. Vert. El.)		Radius (in.)
	6I (60° In. Vert. El.)		-12=12" (205mm)
	4I (45° In. Vert. El.)		-24=24" (610mm)
	3I (30° In. Vert. El.)		-36=36" (914mm)
	FT (Horiz. Tee)		
	FC (Horiz. Cross)		
	TT (Horiz. Tapped Tee)		
	TC (Horiz. Tapped Cross)		
	VT (Vert. Tee)		
	SR (Vert. Cable Support Elbow)		
	ST (Straight Reducer)		
	RH (Right Hand Reducer)		
	LH (Left Hand Reducer)		
	AF (Adjustable Elbow)		
	RY & LY (45° "Y" Branch)		



Certified COPE Systems That Meet Performance Class CSA Std.C22.2

Certified CSA Load Class	Cope System	Load Depth	Side Rail	Flange Width	Max. Load Kg/m (lb/ft)	Maximum Support Span	Deflection at Max Support Span	Meets CSA Elec. Tests
ALUMINUM LADDER TRAY - Safety Factor: 1.5								
C	1B38	3" (76mm)	4¼" (108mm)	⅜" (21mm)	97 (65)	3m	25.1mm	Yes
D	3D38	3" (76mm)	4¼" (108mm)	1¼" (32mm)	67 (45)	6m (1)	108.5mm	Yes
16C	5D38	3" (76mm)	4¼" (108mm)	1¼" (32mm)	149 (100)	4.9m	69.3mm	Yes
C	1B48	4" (102mm)	5½" (133mm)	⅜" (21mm)	97 (65)	3m	22.1mm	Yes
20A	7448	4" (102mm)	5½" (133mm)	1¼" (32mm)	74 (50)	6m (1)	73.4mm	Yes
20B	3D48	4" (102mm)	5½" (133mm)	1¼" (32mm)	112 (75)	6m (1)	79.8mm	Yes
20A	1D58	5" (127mm)	6¼" (159mm)	1¼" (32mm)	74 (50)	6m (1)	63.8mm	Yes
20B	5D58	5" (127mm)	6¼" (159mm)	1¼" (32mm)	112 (75)	6m (1)	54.9mm	Yes
E	3658	5" (127mm)	6¼" (159mm)	1¾" (45mm)	112 (75)	6m (1)	64.8mm	Yes
20C	7D58	5" (127mm)	6¼" (159mm)	1¼" (32mm)	149 (100)	6m (1)	76.7mm	Yes
20C	5D68	6" (152mm)	7¼" (184mm)	1¼" (32mm)	149 (100)	6m (1)	54.9mm	Yes
Mil Gal STEEL LADDER TRAY Safety Factor: 1.5								
C	8B36	3" (76mm)	4¼" (108mm)	⅜" (21mm)	97 (65)	3m	17.8mm	Yes
20A	6456	5" (127mm)	6¼" (159mm)	1¼" (32mm)	74 (50)	6m (1)	40.4mm	Yes
E	6D56	5" (127mm)	6¼" (159mm)	1¼" (32mm)	112 (75)	6m (1)	46.2mm	Yes
20C	4D56	5" (127mm)	6¼" (159mm)	1¼" (32mm)	149 (100)	6m (1)	48.5mm	Yes
12B	8B66	6" (152mm)	7¼" (184mm)	⅜" (21mm)	112 (75)	3.7m	24.9mm	Yes
20A	6466	6" (152mm)	7¼" (184mm)	1¼" (32mm)	74 (50)	6m (1)	23.1mm	Yes
20B	6D66	6" (152mm)	7¼" (184mm)	1¼" (32mm)	112 (75)	6m (1)	33.8mm	Yes
HDGAF STEEL LADDER TRAY Safety Factor: 1.5								
C	8B37	3" (76mm)	4¼" (108mm)	⅜" (21mm)	97 (65)	3m	17.8mm	Yes
20A	6457	5" (127mm)	6¼" (159mm)	1¼" (32mm)	74 (50)	6m (1)	40.4mm	Yes
E	6D57	5" (127mm)	6¼" (159mm)	1¼" (32mm)	112 (75)	6m (1)	46.2mm	Yes
12B	8B67	6" (152mm)	7¼" (184mm)	⅜" (21mm)	112 (75)	3.7m	24.9mm	Yes
20A	6467	6" (152mm)	7¼" (184mm)	1¼" (32mm)	74 (50)	6m (1)	23.1mm	Yes
20B	6D67	6" (152mm)	7¼" (184mm)	1¼" (32mm)	112 (75)	6m (1)	33.8mm	Yes

*Also recommended for 3 meter support spans

CSA LOADS

Identify the desired load designation needed for your project from the chart below. Both CSA Class and NEMA designations are listed by load capability and span. Then select the CSA Certified Cope System from the table above. Where CSA C22.2 is not mandatory, you may want to consider other Cope systems offered on the selection charts (page 25 thru 29).

Load, kg/m (lb/ft)	Span, m (ft)				
	2.4 (8)	3.0 (10)	3.7 (12)	4.9 (16)	6.0 (20)
37 (25)	-	A	-	-	-
67 (45)	-	-	-	-	D
74 (50)	8A	-	12A	16A	20A
97 (65)	-	C	-	-	-
112 (75)	8B	-	12B	16B	E or 20B
149 (100)	8C	-	12C	16C	20C
179 (120)	-	D	-	-	-
299 (200)	-	E	-	-	-

Note: 8A/B/C, 12A/B/C, 16A/B/C, and 20A/B/C have been NEMA designations. A, B, C, D and E have been CSA designations

RECEIVING, INSTALLING, AND MAINTENANCE

The proper care and handling of cable trays by the receiver and installers is very important to insure a safe installation that will meet the intended service life. Cope has an installation guide available to assist the installers and those who will maintain the installed system.

DIMENSIONS AND STRUCTURAL PROPERTIES: COPE CSA SYSTEMS

The performance of the Cope cable trays systems certified by CSA is given above. Structural properties of straight sections, though not required to be listed, are given in the Cope NEMA selection charts, in English units. Dimensions of straight sections and certified fittings are furnished in English and metric units for use in layout and/or entry into computerized systems.

Note: For other CSA approved systems please contact the factory.

LADDER CABLE TRAY SYSTEM

90° HORIZONTAL ELBOW [9F]

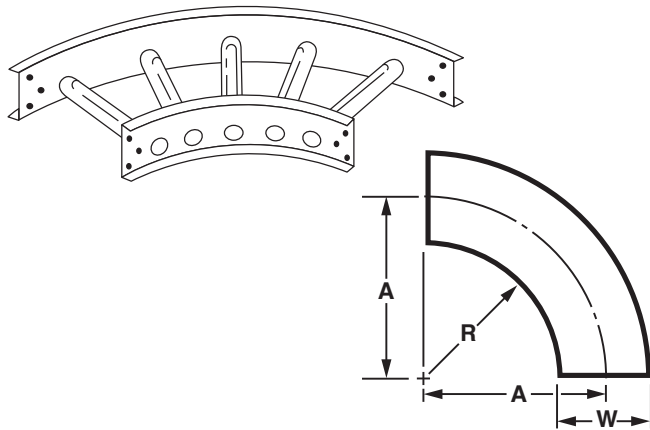

60° HORIZONTAL ELBOW [6F]

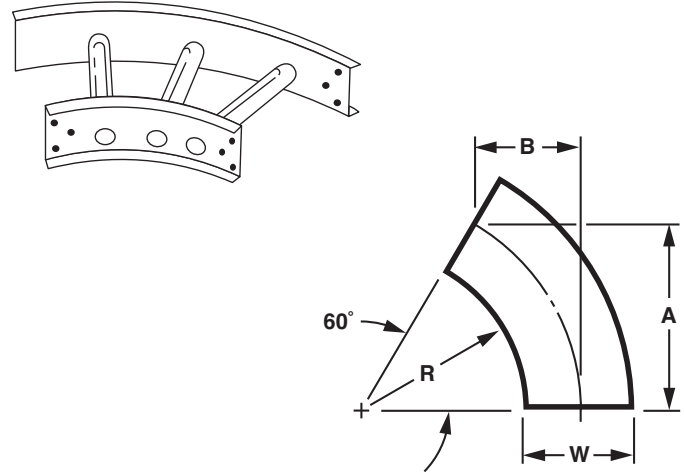

CSA CERTIFIED FOR CSA SYSTEMS

Radius - R	Width - W	"A" Dimension	Part Number
12" (305mm)	6" (152mm)	15" (381mm)	XXX-069F-12
	9" (229mm)	16½" (419mm)	XXX-099F-12
	12" (305mm)	18" (457mm)	XXX-129F-12
	18" (457mm)	21" (533mm)	XXX-189F-12
	24" (610mm)	24" (610mm)	XXX-249F-12
	30" (762mm)	27" (686mm)	XXX-309F-12
	36" (914mm)	30" (762mm)	XXX-369F-12
	42" (1067mm)	33" (838mm)	XXX-429F-12
48" (1219mm)	36" (914mm)	XXX-489F-12	
24" (610mm)	6" (152mm)	27" (686mm)	XXX-069F-24
	9" (229mm)	28½" (724mm)	XXX-099F-24
	12" (305mm)	30" (762mm)	XXX-129F-24
	18" (457mm)	33" (838mm)	XXX-189F-24
	24" (610mm)	36" (914mm)	XXX-249F-24
	30" (762mm)	39" (991mm)	XXX-309F-24
	36" (914mm)	42" (1067mm)	XXX-369F-24
	42" (1067mm)	45" (1143mm)	XXX-429F-24
48" (1219mm)	48" (1219mm)	XXX-489F-24	
36" (914mm)	6" (152mm)	39" (991mm)	XXX-069F-36
	9" (229mm)	40½" (1029mm)	XXX-099F-36
	12" (305mm)	42" (1067mm)	XXX-129F-36
	18" (457mm)	45" (1143mm)	XXX-189F-36
	24" (610mm)	48" (1219mm)	XXX-249F-36
	30" (762mm)	51" (1295mm)	XXX-309F-36
	36" (914mm)	54" (1372mm)	XXX-369F-36
	42" (1067mm)	57" (1448mm)	XXX-429F-36
48" (1219mm)	60" (1524mm)	XXX-489F-36	

Example: 238-129F-12

Note: Use Adjustable Connectors for odd angles. Nominal 9" rung spacing maintained through centerline of all fittings.

CSA CERTIFIED FOR CSA SYSTEMS

Radius - R	Width - W	"A" Dimension	"B" Dimension	Part Number
12" (305mm)	6" (152mm)	13" (330mm)	7½" (191mm)	XXX-066F-12
	9" (229mm)	14¼" (362mm)	8¼" (210mm)	XXX-096F-12
	12" (305mm)	15⅝" (397mm)	9" (229mm)	XXX-126F-12
	18" (457mm)	18¼" (464mm)	10½" (267mm)	XXX-186F-12
	24" (610mm)	20¾" (527mm)	12" (305mm)	XXX-246F-12
	30" (762mm)	23⅜" (594mm)	13½" (343mm)	XXX-306F-12
	36" (914mm)	26" (660mm)	15" (381mm)	XXX-366F-12
	42" (1067mm)	28⅝" (725mm)	16½" (419mm)	XXX-426F-12
48" (1219mm)	31⅝" (791mm)	18" (457mm)	XXX-486F-12	
24" (610mm)	6" (152mm)	23⅝" (594mm)	13½" (343mm)	XXX-066F-24
	9" (229mm)	24¾" (629mm)	14¼" (362mm)	XXX-096F-24
	12" (305mm)	26" (660mm)	15" (381mm)	XXX-126F-24
	18" (457mm)	28⅝" (727mm)	16½" (416mm)	XXX-186F-24
	24" (610mm)	31¼" (794mm)	18" (457mm)	XXX-246F-24
	30" (762mm)	33¾" (857mm)	19½" (495mm)	XXX-306F-24
	36" (914mm)	36⅝" (924mm)	21" (533mm)	XXX-366F-24
	42" (1067mm)	38⅝" (989mm)	22½" (572mm)	XXX-426F-24
48" (1219mm)	41⅝" (1056mm)	24" (610mm)	XXX-486F-24	
36" (914mm)	6" (152mm)	33¾" (857mm)	19½" (495mm)	XXX-066F-36
	9" (229mm)	35⅝" (892mm)	20¼" (514mm)	XXX-096F-36
	12" (305mm)	36⅝" (924mm)	21" (533mm)	XXX-126F-36
	18" (457mm)	39" (991mm)	22½" (572mm)	XXX-186F-36
	24" (610mm)	41⅝" (1057mm)	24" (610mm)	XXX-246F-36
	30" (762mm)	44⅝" (1121mm)	25½" (648mm)	XXX-306F-36
	36" (914mm)	46¾" (1187mm)	27" (686mm)	XXX-366F-36
	42" (1067mm)	49⅝" (1253mm)	28½" (724mm)	XXX-426F-36
48" (1219mm)	51⅝" (1319mm)	30" (762mm)	XXX-486F-36	

Example: 238-126F-12

See Page 50
for Electrical
Grounding Chart

45° HORIZONTAL ELBOW [4F]

30° HORIZONTAL ELBOW [3F]

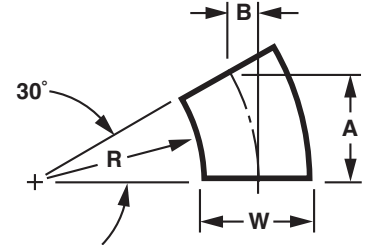
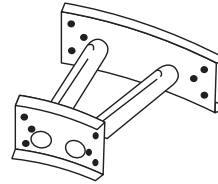
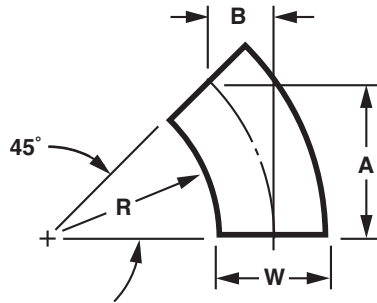
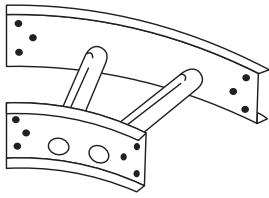

CSA CERTIFIED FOR CSA SYSTEMS

Radius - R	Width - W	"A" Dimension	"B" Dimension	Part Number
12" (305mm)	6" (152mm)	10 ⁵ / ₈ " (270mm)	4 ⁷ / ₈ " (111mm)	XXX-064F-12
	9" (229mm)	11 ⁵ / ₈ " (295mm)	4 ⁷ / ₈ " (124mm)	XXX-094F-12
	12" (305mm)	12 ³ / ₄ " (324mm)	5 ¹ / ₄ " (133mm)	XXX-124F-12
	18" (457mm)	14 ⁷ / ₈ " (378mm)	6 ⁷ / ₈ " (156mm)	XXX-184F-12
	24" (610mm)	17" (432mm)	7" (178mm)	XXX-244F-12
	30" (762mm)	19 ⁷ / ₈ " (486mm)	7 ⁷ / ₈ " (200mm)	XXX-304F-12
	36" (914mm)	21 ¹ / ₄ " (540mm)	8 ³ / ₄ " (222mm)	XXX-364F-12
	42" (1067mm)	23 ⁵ / ₈ " (592mm)	9 ⁵ / ₈ " (244mm)	XXX-424F-12
48" (1219mm)	25 ⁷ / ₈ " (646mm)	10 ¹ / ₂ " (267mm)	XXX-484F-12	
24" (610mm)	6" (152mm)	19 ¹ / ₈ " (486mm)	7 ⁷ / ₈ " (200mm)	XXX-064F-24
	9" (229mm)	20 ¹ / ₈ " (511mm)	8 ³ / ₄ " (213mm)	XXX-094F-24
	12" (305mm)	21 ¹ / ₄ " (540mm)	8 ³ / ₄ " (222mm)	XXX-124F-24
	18" (457mm)	23 ³ / ₈ " (594mm)	9 ⁵ / ₈ " (244mm)	XXX-184F-24
	24" (610mm)	25 ¹ / ₂ " (648mm)	10 ¹ / ₂ " (267mm)	XXX-244F-24
	30" (762mm)	27 ⁵ / ₈ " (702mm)	11 ¹ / ₂ " (292mm)	XXX-304F-24
	36" (914mm)	29 ³ / ₄ " (756mm)	12 ³ / ₈ " (314mm)	XXX-364F-24
	42" (1067mm)	31 ¹ / ₈ " (808mm)	13 ¹ / ₈ " (333mm)	XXX-424F-24
48" (1219mm)	33 ¹ / ₈ " (862mm)	14" (356mm)	XXX-484F-24	
36" (914mm)	6" (152mm)	27 ⁵ / ₈ " (702mm)	11 ¹ / ₂ " (292mm)	XXX-064F-36
	9" (229mm)	28 ⁵ / ₈ " (727mm)	11 ⁷ / ₈ " (302mm)	XXX-094F-36
	12" (305mm)	29 ³ / ₄ " (756mm)	12 ³ / ₈ " (314mm)	XXX-124F-36
	18" (457mm)	31 ¹ / ₈ " (810mm)	13 ¹ / ₄ " (337mm)	XXX-184F-36
	24" (610mm)	34" (864mm)	14 ¹ / ₈ " (359mm)	XXX-244F-36
	30" (762mm)	36 ¹ / ₈ " (918mm)	15" (381mm)	XXX-304F-36
	36" (914mm)	38 ¹ / ₄ " (972mm)	15 ⁷ / ₈ " (403mm)	XXX-364F-36
	42" (1067mm)	40 ¹ / ₄ " (1022mm)	16 ¹ / ₈ " (424mm)	XXX-424F-36
48" (1219mm)	42 ³ / ₈ " (1076mm)	17 ¹ / ₈ " (446mm)	XXX-484F-36	

Example: 238-124F-12

Note: Use Adjustable Connectors for odd angles. Nominal 9" rung spacing maintained through centerline of all fittings.

CSA CERTIFIED FOR CSA SYSTEMS

Radius - R	Width - W	"A" Dimension	"B" Dimension	Part Number
12" (305mm)	6" (152mm)	7 ¹ / ₂ " (191mm)	2" (51mm)	XXX-063F-12
	9" (229mm)	8 ¹ / ₄ " (210mm)	2 ¹ / ₄ " (57mm)	XXX-093F-12
	12" (305mm)	9" (229mm)	2 ³ / ₈ " (60mm)	XXX-123F-12
	18" (457mm)	10 ¹ / ₂ " (267mm)	2 ⁷ / ₈ " (73mm)	XXX-183F-12
	24" (610mm)	12" (305mm)	3 ¹ / ₄ " (83mm)	XXX-243F-12
	30" (762mm)	13 ¹ / ₂ " (343mm)	3 ⁵ / ₈ " (92mm)	XXX-303F-12
	36" (914mm)	15" (381mm)	4" (102mm)	XXX-363F-12
	42" (1067mm)	16 ¹ / ₂ " (419mm)	4 ³ / ₈ " (111mm)	XXX-423F-12
48" (1219mm)	18" (457mm)	4 ¹ / ₈ " (122mm)	XXX-483F-12	
24" (610mm)	6" (152mm)	13 ¹ / ₂ " (343mm)	3 ⁵ / ₈ " (92mm)	XXX-063F-24
	9" (229mm)	14 ¹ / ₄ " (362mm)	3 ⁷ / ₈ " (98mm)	XXX-093F-24
	12" (305mm)	15" (381mm)	4" (102mm)	XXX-123F-24
	18" (457mm)	16 ¹ / ₂ " (419mm)	4 ³ / ₈ " (111mm)	XXX-183F-24
	24" (610mm)	18" (457mm)	4 ⁷ / ₈ " (124mm)	XXX-243F-24
	30" (762mm)	19 ¹ / ₂ " (495mm)	5 ¹ / ₄ " (133mm)	XXX-303F-24
	36" (914mm)	21" (533mm)	5 ⁵ / ₈ " (143mm)	XXX-363F-24
	42" (1067mm)	22 ¹ / ₂ " (572mm)	6" (152mm)	XXX-423F-24
48" (1219mm)	24" (610mm)	6 ³ / ₈ " (162mm)	XXX-483F-24	
36" (914mm)	6" (152mm)	19 ¹ / ₂ " (495mm)	5 ¹ / ₄ " (133mm)	XXX-063F-36
	9" (229mm)	20 ¹ / ₄ " (514mm)	5 ¹ / ₂ " (140mm)	XXX-093F-36
	12" (305mm)	21" (533mm)	5 ⁵ / ₈ " (143mm)	XXX-123F-36
	18" (457mm)	22 ¹ / ₂ " (572mm)	6" (152mm)	XXX-183F-36
	24" (610mm)	24" (610mm)	6 ¹ / ₂ " (165mm)	XXX-243F-36
	30" (762mm)	25 ¹ / ₂ " (648mm)	6 ⁵ / ₈ " (175mm)	XXX-303F-36
	36" (914mm)	27" (686mm)	7 ¹ / ₄ " (184mm)	XXX-363F-36
	42" (1067mm)	28 ¹ / ₂ " (724mm)	7 ⁵ / ₈ " (194mm)	XXX-423F-36
48" (1219mm)	30" (762mm)	8" (203mm)	XXX-483F-36	

Example: 238-123F-12

See Page 50
for Electrical
Grounding Chart

LADDER CABLE TRAY SYSTEM

HORIZONTAL TEE [FT]

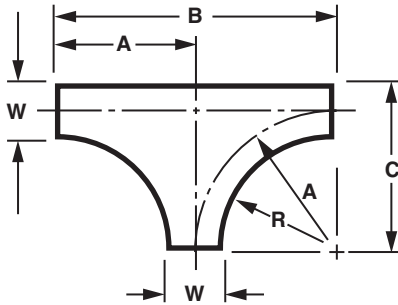
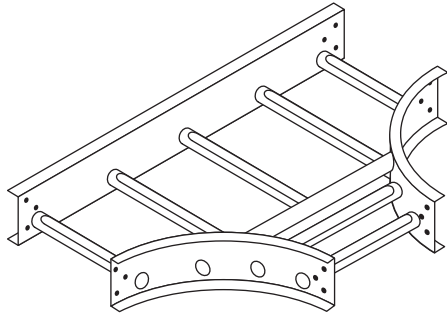

CSA CERTIFIED FOR CSA SYSTEMS

Radius - R	Width - W	"A" Dimension	"B" Dimension	"C" Dimension	Part Number
12" (305mm)	6" (152mm)	15" (381mm)	30" (762mm)	18" (457mm)	XXX-06FT-12
	9" (229mm)	16½" (419mm)	33" (838mm)	21" (533mm)	XXX-09FT-12
	12" (305mm)	18" (457mm)	36" (914mm)	24" (610mm)	XXX-12FT-12
	18" (457mm)	21" (533mm)	42" (1067mm)	30" (762mm)	XXX-18FT-12
	24" (610mm)	24" (610mm)	48" (1219mm)	36" (914mm)	XXX-24FT-12
	30" (762mm)	27" (686mm)	54" (1372mm)	42" (1067mm)	XXX-30FT-12
	36" (914mm)	30" (762mm)	60" (1524mm)	48" (1219mm)	XXX-36FT-12
	42" (1067mm)	33" (838mm)	66" (1676mm)	54" (1372mm)	XXX-42FT-12
48" (1219mm)	36" (914mm)	72" (1829mm)	60" (1524mm)	XXX-48FT-12	
24" (610mm)	6" (152mm)	27" (686mm)	54" (1372mm)	30" (762mm)	XXX-06FT-24
	9" (229mm)	28½" (724mm)	57" (1448mm)	33" (838mm)	XXX-09FT-24
	12" (305mm)	30" (762mm)	60" (1524mm)	36" (914mm)	XXX-12FT-24
	18" (457mm)	33" (838mm)	66" (1676mm)	42" (1067mm)	XXX-18FT-24
	24" (610mm)	36" (914mm)	72" (1829mm)	48" (1219mm)	XXX-24FT-24
	30" (762mm)	39" (991mm)	78" (1981mm)	54" (1372mm)	XXX-30FT-24
	36" (914mm)	42" (1067mm)	84" (2134mm)	60" (1524mm)	XXX-36FT-24
	42" (1067mm)	45" (1143mm)	90" (2286mm)	66" (1676mm)	XXX-42FT-24
48" (1219mm)	48" (1219mm)	96" (2438mm)	72" (1829mm)	XXX-48FT-24	
36" (914mm)	6" (152mm)	39" (991mm)	78" (1981mm)	42" (1067mm)	XXX-06FT-36
	9" (229mm)	40½" (1029mm)	81" (2057mm)	45" (1143mm)	XXX-09FT-36
	12" (305mm)	42" (1067mm)	84" (2134mm)	48" (1219mm)	XXX-12FT-36
	18" (457mm)	45" (1143mm)	90" (2286mm)	54" (1372mm)	XXX-18FT-36
	24" (610mm)	48" (1219mm)	96" (2438mm)	60" (1524mm)	XXX-24FT-36
	30" (762mm)	51" (1295mm)	102" (2591mm)	66" (1676mm)	XXX-30FT-36
	36" (914mm)	54" (1372mm)	108" (2743mm)	72" (1829mm)	XXX-36FT-36
	42" (1067mm)	57" (1448mm)	114" (2896mm)	78" (1981mm)	XXX-42FT-36
48" (1219mm)	60" (1524mm)	120" (3048mm)	84" (2134mm)	XXX-48FT-36	

Example: 238-12FT-12

Note: Nominal 9" rung spacing maintained through centerline of all fittings.

See Page 50
for Electrical
Grounding Chart

HORIZONTAL CROSS [FC]

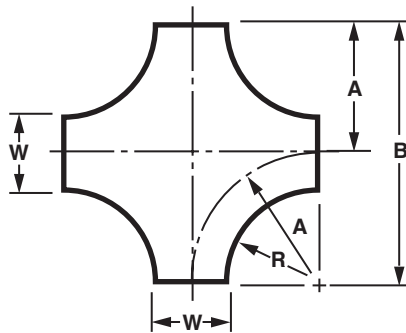
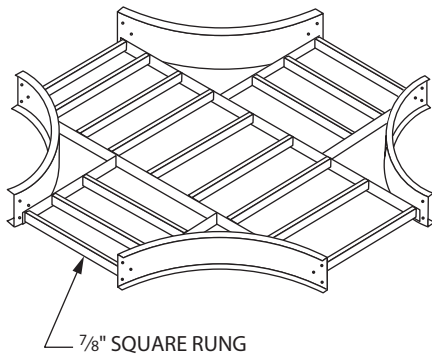

CSA CERTIFIED FOR CSA SYSTEMS

Radius - R	Width - W	"A" Dimension	"B" Dimension	Part Number
12" (305mm)	6" (152mm)	15" (381mm)	30" (762mm)	XXX-06FC-12
	9" (229mm)	16½" (419mm)	33" (838mm)	XXX-09FC-12
	12" (305mm)	18" (457mm)	36" (914mm)	XXX-12FC-12
	18" (457mm)	21" (533mm)	42" (1067mm)	XXX-18FC-12
	24" (610mm)	24" (610mm)	48" (1219mm)	XXX-24FC-12
	30" (762mm)	27" (686mm)	54" (1372mm)	XXX-30FC-12
	36" (914mm)	30" (762mm)	60" (1524mm)	XXX-36FC-12
	42" (1067mm)	33" (838mm)	66" (1676mm)	XXX-42FC-12
24" (610mm)	48" (1219mm)	36" (914mm)	72" (1829mm)	XXX-48FC-12
	6" (152mm)	27" (686mm)	54" (1372mm)	XXX-06FC-24
	9" (229mm)	28½" (724mm)	57" (1448mm)	XXX-09FC-24
	12" (305mm)	30" (762mm)	60" (1524mm)	XXX-12FC-24
	18" (457mm)	33" (838mm)	66" (1676mm)	XXX-18FC-24
	24" (610mm)	36" (914mm)	72" (1829mm)	XXX-24FC-24
	30" (762mm)	39" (991mm)	78" (1981mm)	XXX-30FC-24
	36" (914mm)	42" (1067mm)	84" (2134mm)	XXX-36FC-24
36" (914mm)	42" (1067mm)	45" (1143mm)	90" (2286mm)	XXX-42FC-24
	48" (1219mm)	48" (1219mm)	96" (2438mm)	XXX-48FC-24
	6" (152mm)	39" (991mm)	78" (1981mm)	XXX-06FC-36
	9" (229mm)	40½" (1029mm)	81" (2057mm)	XXX-09FC-36
	12" (305mm)	42" (1067mm)	84" (2134mm)	XXX-12FC-36
	18" (457mm)	45" (1143mm)	90" (2286mm)	XXX-18FC-36
	24" (610mm)	48" (1219mm)	96" (2438mm)	XXX-24FC-36
	30" (762mm)	51" (1295mm)	102" (2591mm)	XXX-30FC-36
36" (914mm)	36" (914mm)	54" (1372mm)	108" (2743mm)	XXX-36FC-36
	42" (1067mm)	57" (1448mm)	114" (2896mm)	XXX-42FC-36
	48" (1219mm)	60" (1524mm)	120" (3048mm)	XXX-48FC-36

Example: 238-12FC-12

Note: Nominal 9" rung spacing maintained through centerline of all fittings.

See Page 50
for Electrical
Grounding Chart

LADDER CABLE TRAY SYSTEM

HORIZONTAL TAPPED TEE [TT]

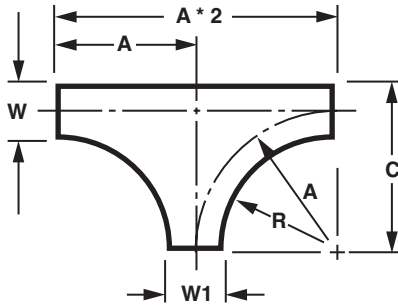
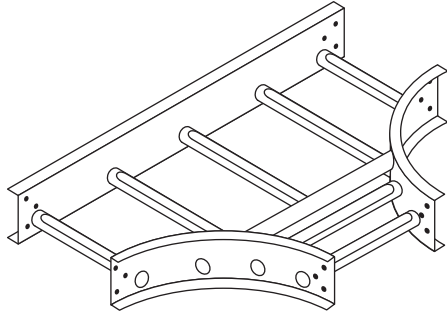

CSA CERTIFIED FOR CSA SYSTEMS

R Radius	W Width	W1 Width	"A" Dimension	"C" Dimension	Part Number			
48" (1219mm)		42" (1067mm)	33" (838mm)	60" (1524mm)	XXX-48TT-42-12			
		36" (914mm)	30" (762mm)		XXX-48TT-36-12			
		30" (762mm)	27" (686mm)		XXX-48TT-30-12			
		24" (610mm)	24" (610mm)		XXX-48TT-24-12			
		18" (457mm)	21" (533mm)		XXX-48TT-18-12			
		12" (305mm)	18" (457mm)		XXX-48TT-12-12			
		9" (229mm)	16½" (419mm)		XXX-48TT-09-12			
		6" (152mm)	15" (381mm)		XXX-48TT-06-12			
		42" (1067mm)			36" (914mm)	30" (762mm)	54" (1372mm)	XXX-42TT-36-12
					30" (762mm)	27" (686mm)		XXX-42TT-30-12
					24" (610mm)	24" (610mm)		XXX-42TT-24-12
					18" (457mm)	21" (533mm)		XXX-42TT-18-12
12" (305mm)	18" (457mm)			XXX-42TT-12-12				
9" (229mm)	16½" (419mm)			XXX-42TT-09-12				
36" (914mm)		30" (762mm)	27" (686mm)	48" (1219mm)	XXX-36TT-30-12			
		24" (610mm)	24" (610mm)		XXX-36TT-24-12			
		18" (457mm)	21" (533mm)		XXX-36TT-18-12			
		12" (305mm)	18" (457mm)		XXX-36TT-12-12			
		9" (229mm)	16½" (419mm)		XXX-36TT-09-12			
		6" (152mm)	15" (381mm)		XXX-36TT-06-12			
30" (762mm)		24" (610mm)	24" (610mm)	42" (1067mm)	XXX-30TT-24-12			
		18" (457mm)	21" (533mm)		XXX-30TT-18-12			
		12" (305mm)	18" (457mm)		XXX-30TT-12-12			
		9" (229mm)	16½" (419mm)		XXX-30TT-09-12			
		6" (152mm)	15" (381mm)		XXX-30TT-06-12			
		24" (610mm)			18" (457mm)	21" (533mm)	36" (914mm)	XXX-24TT-18-12
12" (305mm)	18" (457mm)			XXX-24TT-12-12				
9" (229mm)	16½" (419mm)			XXX-24TT-09-12				
6" (152mm)	15" (381mm)			XXX-24TT-06-12				
18" (457mm)				12" (305mm)	18" (457mm)	30" (762mm)		XXX-18TT-12-12
				9" (229mm)	16½" (419mm)			XXX-18TT-09-12
		6" (152mm)	15" (381mm)	XXX-18TT-06-12				
12" (305mm)		9" (229mm)	16½" (419mm)	24" (610mm)	XXX-12TT-09-12			
		6" (152mm)	15" (381mm)		XXX-12TT-06-12			
9" (229mm)		6" (152mm)	15" (381mm)	21" (610mm)	XXX-09TT-06-12			

Example: 238-12TT-12

Note: Nominal 9" rung spacing maintained through centerline of all fittings.

See Page 50
for Electrical
Grounding Chart

HORIZONTAL TAPPED TEE [TT] continued

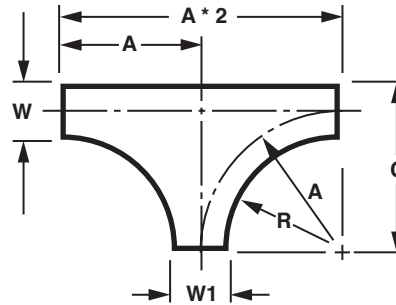

See Page 50
for Electrical
Grounding Chart

CSA CERTIFIED FOR CSA SYSTEMS

R Radius	W Width	W1 Width	"A" Dimension	"C" Dimension	Part Number			
48" (1219mm)	48" (1219mm)	42" (1067mm)	45" (1143mm)	72" (1829mm)	XXX-48TT-42-24			
		36" (914mm)	42" (1067mm)		XXX-48TT-36-24			
		30" (762mm)	39" (991mm)		XXX-48TT-30-24			
		24" (610mm)	36" (914mm)		XXX-48TT-24-24			
		18" (457mm)	33" (838mm)		XXX-48TT-18-24			
		12" (305mm)	30" (762mm)		XXX-48TT-12-24			
		9" (229mm)	28½" (724mm)		XXX-48TT-09-24			
		6" (152mm)	27" (686mm)		XXX-48TT-06-24			
42" (1067mm)	42" (1067mm)	36" (914mm)	42" (1067mm)	66" (1676mm)	XXX-42TT-36-24			
		30" (762mm)	39" (991mm)		XXX-42TT-30-24			
		24" (610mm)	36" (914mm)		XXX-42TT-24-24			
		18" (457mm)	33" (838mm)		XXX-42TT-18-24			
		12" (305mm)	30" (762mm)		XXX-42TT-12-24			
		9" (229mm)	28½" (724mm)		XXX-42TT-09-24			
		6" (152mm)	27" (686mm)		XXX-42TT-06-24			
		24" (610mm)	36" (914mm)		30" (762mm)	39" (991mm)	60" (1524mm)	XXX-36TT-30-24
24" (610mm)	36" (914mm)			XXX-36TT-24-24				
18" (457mm)	33" (838mm)			XXX-36TT-18-24				
12" (305mm)	30" (762mm)			XXX-36TT-12-24				
9" (229mm)	28½" (724mm)			XXX-36TT-09-24				
6" (152mm)	27" (686mm)			XXX-36TT-06-24				
30" (762mm)	24" (610mm)			18" (457mm)	33" (838mm)	54" (1372mm)		XXX-30TT-24-24
				12" (305mm)	30" (762mm)			XXX-30TT-18-24
		9" (229mm)	28½" (724mm)	XXX-30TT-12-24				
		6" (152mm)	27" (686mm)	XXX-30TT-09-24				
		6" (152mm)	27" (686mm)	XXX-30TT-06-24				
		24" (610mm)	18" (457mm)	12" (305mm)	30" (762mm)		48" (1219mm)	XXX-24TT-18-24
9" (229mm)	28½" (724mm)			XXX-24TT-12-24				
6" (152mm)	27" (686mm)			XXX-24TT-09-24				
6" (152mm)	27" (686mm)			XXX-24TT-06-24				
18" (457mm)	12" (305mm)	9" (229mm)	30" (762mm)	42" (1067mm)	XXX-18TT-12-24			
		6" (152mm)	28½" (724mm)		XXX-18TT-09-24			
		6" (152mm)	27" (686mm)		XXX-18TT-06-24			
12" (305mm)	9" (229mm)	6" (152mm)	28½" (724mm)	36" (914mm)	XXX-12TT-09-24			
		6" (152mm)	27" (686mm)		XXX-12TT-06-24			
9" (229mm)	6" (152mm)	27" (686mm)	33" (838mm)	33" (838mm)	XXX-09TT-06-24			

CSA CERTIFIED FOR CSA SYSTEMS

R Radius	W Width	W1 Width	"A" Dimension	"C" Dimension	Part Number			
48" (1219mm)	48" (1219mm)	42" (1067mm)	57" (1448mm)	84" (2134mm)	XXX-48TT-42-36			
		36" (914mm)	54" (1372mm)		XXX-48TT-36-36			
		30" (762mm)	51" (1295mm)		XXX-48TT-30-36			
		24" (610mm)	48" (1219mm)		XXX-48TT-24-36			
		18" (457mm)	45" (1143mm)		XXX-48TT-18-36			
		12" (305mm)	42" (1067mm)		XXX-48TT-12-36			
		9" (229mm)	40½" (1029mm)		XXX-48TT-09-36			
		6" (152mm)	39" (991mm)		XXX-48TT-06-36			
42" (1067mm)	42" (1067mm)	36" (914mm)	54" (1372mm)	78" (1981mm)	XXX-42TT-36-36			
		30" (762mm)	51" (1295mm)		XXX-42TT-30-36			
		24" (610mm)	48" (1219mm)		XXX-42TT-24-36			
		18" (457mm)	45" (1143mm)		XXX-42TT-18-36			
		12" (305mm)	42" (1067mm)		XXX-42TT-12-36			
		9" (229mm)	40½" (1029mm)		XXX-42TT-09-36			
		6" (152mm)	39" (991mm)		XXX-42TT-06-36			
		36" (914mm)	36" (914mm)		30" (762mm)	51" (1295mm)	72" (1829mm)	XXX-36TT-30-36
24" (610mm)	48" (1219mm)			XXX-36TT-24-36				
18" (457mm)	45" (1143mm)			XXX-36TT-18-36				
12" (305mm)	42" (1067mm)			XXX-36TT-12-36				
9" (229mm)	40½" (1029mm)			XXX-36TT-09-36				
6" (152mm)	39" (991mm)			XXX-36TT-06-36				
30" (762mm)	24" (610mm)			18" (457mm)	48" (1219mm)	66" (1676mm)		XXX-30TT-24-36
				12" (305mm)	45" (1143mm)			XXX-30TT-18-36
		9" (229mm)	42" (1067mm)	XXX-30TT-12-36				
		6" (152mm)	40½" (1029mm)	XXX-30TT-09-36				
		6" (152mm)	39" (991mm)	XXX-30TT-06-36				
		24" (610mm)	18" (457mm)	12" (305mm)	45" (1143mm)		60"	XXX-24TT-18-36
9" (229mm)	42" (1067mm)			XXX-24TT-12-36				
6" (152mm)	40½" (1029mm)			XXX-24TT-09-36				
6" (152mm)	39" (991mm)			XXX-24TT-06-36				
18" (457mm)	12" (305mm)	9" (229mm)	42" (1067mm)	54"	XXX-18TT-12-36			
		6" (152mm)	40½" (1029mm)		XXX-18TT-09-36			
		6" (152mm)	39" (991mm)		XXX-18TT-06-36			
12" (305mm)	9" (229mm)	6" (152mm)	40½" (1029mm)	48" (1219mm)	XXX-12TT-09-36			
		6" (152mm)	39" (991mm)		XXX-12TT-06-36			
9" (229mm)	6" (152mm)	39" (991mm)	45" (1143mm)	45" (1143mm)	XXX-09TT-06-36			

LADDER CABLE TRAY SYSTEM

HORIZONTAL TAPPED CROSS [TC]

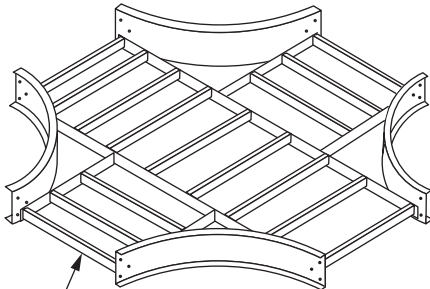

7/8" SQUARE RUNG

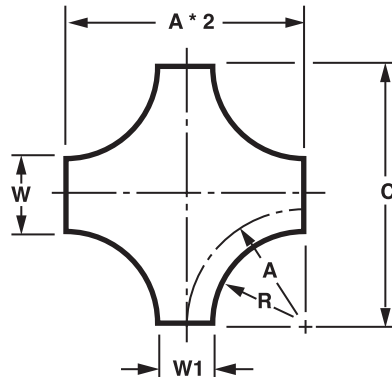

CSA CERTIFIED FOR CSA SYSTEMS

R Radius	W Width	W1 Width	"A" Dimension	"C" Dimension	Part Number
12" (305mm)	48" (1219mm)	42" (1067mm)	33" (838mm)	72" (1829mm)	XXX-48TC-42-12
		36" (914mm)	30" (762mm)		XXX-48TC-36-12
		30" (762mm)	27" (686mm)		XXX-48TC-30-12
		24" (610mm)	24" (610mm)		XXX-48TC-24-12
		18" (457mm)	21" (533mm)		XXX-48TC-18-12
		12" (305mm)	18" (457mm)		XXX-48TC-12-12
		9" (229mm)	16½" (419mm)		XXX-48TC-09-12
	6" (152mm)	15" (381mm)	XXX-48TC-06-12		
	42" (1067mm)	36" (914mm)	30" (762mm)	66" (1676mm)	XXX-42TC-36-12
		30" (762mm)	27" (686mm)		XXX-42TC-30-12
		24" (610mm)	24" (610mm)		XXX-42TC-24-12
		18" (457mm)	21" (533mm)		XXX-42TC-18-12
		12" (305mm)	18" (457mm)		XXX-42TC-12-12
	36" (914mm)	30" (762mm)	27" (686mm)	60" (1524mm)	XXX-36TC-30-12
24" (610mm)		24" (610mm)	XXX-36TC-24-12		
18" (457mm)		21" (533mm)	XXX-36TC-18-12		
12" (305mm)		18" (457mm)	XXX-36TC-12-12		
9" (229mm)		16½" (419mm)	XXX-36TC-09-12		
30" (762mm)	24" (610mm)	24" (610mm)	54" (1372mm)	XXX-30TC-24-12	
	18" (457mm)	21" (533mm)		XXX-30TC-18-12	
	12" (305mm)	18" (457mm)		XXX-30TC-12-12	
	9" (229mm)	16½" (419mm)		XXX-30TC-09-12	
24" (610mm)	18" (457mm)	21" (533mm)	48" (1219mm)	XXX-24TC-18-12	
	12" (305mm)	18" (457mm)		XXX-24TC-12-12	
	9" (229mm)	16½" (419mm)		XXX-24TC-09-12	
	6" (152mm)	15" (381mm)		XXX-24TC-06-12	
18" (457mm)	12" (305mm)	18" (457mm)	42" (1067mm)	XXX-18TC-12-12	
	9" (229mm)	16½" (419mm)		XXX-18TC-09-12	
	6" (152mm)	15" (381mm)		XXX-18TC-06-12	
12" (305mm)	9" (229mm)	16½" (419mm)	36" (914mm)	XXX-12TC-09-12	
	6" (152mm)	15" (381mm)		XXX-12TC-06-12	
9" (229mm)	6" (152mm)	15" (381mm)	33" (838mm)	XXX-09TC-06-12	

Example: 238-36TC-18-12

Note: Nominal 9" rung spacing maintained through centerline of all fittings.

See Page 50
for Electrical
Grounding Chart

HORIZONTAL TAPPED CROSS [TC] continued

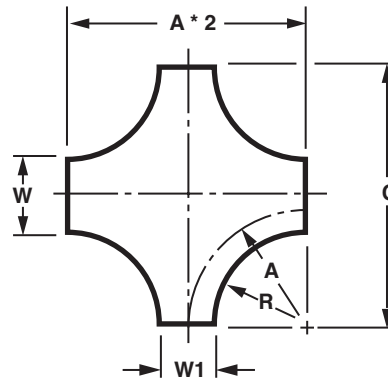

See Page 50
for Electrical
Grounding Chart

CSA CERTIFIED FOR CSA SYSTEMS

R Radius	W Width	W1 Width	"A" Dimension	"C" Dimension	Part Number
24" (610mm)	48" (1219mm)	42" (1067mm)	45" (1143mm)	96" (2438mm)	XXX-48TC-42-24
		36" (914mm)	42" (1067mm)		XXX-48TC-36-24
		30" (762mm)	39" (991mm)		XXX-48TC-30-24
		24" (610mm)	36" (914mm)		XXX-48TC-24-24
		18" (457mm)	33" (838mm)		XXX-48TC-18-24
		12" (305mm)	30" (762mm)		XXX-48TC-12-24
		9" (229mm)	28½" (724mm)		XXX-48TC-09-24
		6" (152mm)	27" (686mm)		XXX-48TC-06-24
	42" (1067mm)	36" (914mm)	42" (1067mm)	90" (2286mm)	XXX-42TC-36-24
		30" (762mm)	39" (991mm)		XXX-42TC-30-24
		24" (610mm)	36" (914mm)		XXX-42TC-24-24
		18" (457mm)	33" (838mm)		XXX-42TC-18-24
		12" (305mm)	30" (762mm)		XXX-42TC-12-24
		9" (229mm)	28½" (724mm)		XXX-42TC-09-24
		6" (152mm)	27" (686mm)		XXX-42TC-06-24
		30" (762mm)	39" (991mm)		XXX-36TC-30-24
	36" (914mm)	24" (610mm)	36" (914mm)	84" (2134mm)	XXX-36TC-24-24
		18" (457mm)	33" (838mm)		XXX-36TC-18-24
		12" (305mm)	30" (762mm)		XXX-36TC-12-24
		9" (229mm)	28½" (724mm)		XXX-36TC-09-24
		6" (152mm)	27" (686mm)		XXX-36TC-06-24
	30" (762mm)	24" (610mm)	36" (914mm)	78" (1981mm)	XXX-30TC-24-24
		18" (457mm)	33" (838mm)		XXX-30TC-18-24
		12" (305mm)	30" (762mm)		XXX-30TC-12-24
		9" (229mm)	28½" (724mm)		XXX-30TC-09-24
		6" (152mm)	27" (686mm)		XXX-30TC-06-24
	24" (610mm)	18" (457mm)	33" (838mm)	72" (1829mm)	XXX-24TC-18-24
		12" (305mm)	30" (762mm)		XXX-24TC-12-24
9" (229mm)		28½" (724mm)	XXX-24TC-09-24		
6" (152mm)		27" (686mm)	XXX-24TC-06-24		
18" (457mm)	12" (305mm)	30" (762mm)	66" (1676mm)	XXX-18TC-12-24	
	9" (229mm)	28½" (724mm)		XXX-18TC-09-24	
	6" (152mm)	27" (686mm)		XXX-18TC-06-24	
12" (305mm)	9" (229mm)	28½" (724mm)	60" (1524mm)	XXX-12TC-09-24	
	6" (152mm)	27" (686mm)		XXX-12TC-06-24	
9" (229mm)	6" (152mm)	27" (686mm)	57" (1448mm)	XXX-09TC-06-24	

CSA CERTIFIED FOR CSA SYSTEMS

R Radius	W Width	W1 Width	"A" Dimension	"C" Dimension	Part Number
48" (1219mm)	48" (1219mm)	42" (1067mm)	57" (1448mm)	120" (3048mm)	XXX-48TC-42-36
		36" (914mm)	54" (1372mm)		XXX-48TC-36-36
		30" (762mm)	51" (1295mm)		XXX-48TC-30-36
		24" (610mm)	48" (1219mm)		XXX-48TC-24-36
		18" (457mm)	45" (1143mm)		XXX-48TC-18-36
		12" (305mm)	42" (1067mm)		XXX-48TC-12-36
		9" (229mm)	40½" (1029mm)		XXX-48TC-09-36
		6" (152mm)	39" (991mm)		XXX-48TC-06-36
	42" (1067mm)	36" (914mm)	54" (1372mm)	114" (2896mm)	XXX-42TC-36-36
		30" (762mm)	51" (1295mm)		XXX-42TC-30-36
		24" (610mm)	48" (1219mm)		XXX-42TC-24-36
		18" (457mm)	45" (1143mm)		XXX-42TC-18-36
		12" (305mm)	42" (1067mm)		XXX-42TC-12-36
		9" (229mm)	40½" (1029mm)		XXX-42TC-09-36
36" (914mm)	36" (914mm)	30" (762mm)	51" (1295mm)	108" (2743mm)	XXX-36TC-30-36
		24" (610mm)	48" (1219mm)		XXX-36TC-24-36
		18" (457mm)	45" (1143mm)		XXX-36TC-18-36
		12" (305mm)	42" (1067mm)		XXX-36TC-12-36
	30" (762mm)	9" (229mm)	40½" (1029mm)		XXX-36TC-09-36
		6" (152mm)	39" (991mm)		XXX-36TC-06-36
		24" (610mm)	48" (1219mm)		XXX-30TC-24-36
		18" (457mm)	45" (1143mm)		XXX-30TC-18-36
24" (610mm)	12" (305mm)	42" (1067mm)	102" (2591mm)	XXX-30TC-12-36	
	9" (229mm)	40½" (1029mm)		XXX-30TC-09-36	
	6" (152mm)	39" (991mm)		XXX-30TC-06-36	
	18" (457mm)	45" (1143mm)		XXX-24TC-18-36	
18" (457mm)	12" (305mm)	42" (1067mm)	96" (2438mm)	XXX-24TC-12-36	
	9" (229mm)	40½" (1029mm)		XXX-24TC-09-36	
	6" (152mm)	39" (991mm)		XXX-24TC-06-36	
	12" (305mm)	42" (1067mm)		XXX-18TC-12-36	
12" (305mm)	9" (229mm)	40½" (1029mm)	90" (2286mm)	XXX-18TC-09-36	
	6" (152mm)	39" (991mm)		XXX-18TC-06-36	
	9" (229mm)	40½" (1029mm)		XXX-12TC-09-36	
9" (229mm)	6" (152mm)	39" (991mm)	84" (2134mm)	XXX-12TC-06-36	
	6" (152mm)	39" (991mm)		81" (2057mm)	XXX-09TC-06-36

LADDER CABLE TRAY SYSTEM

LEFT HAND [LH] & RIGHT HAND [RH] REDUCER

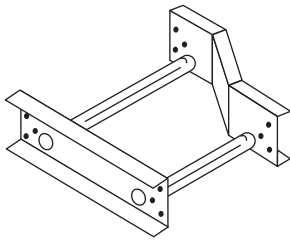

RIGHT HAND (RH)

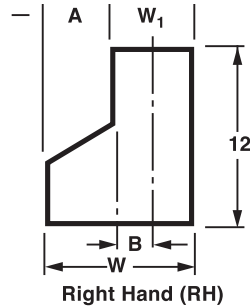

Right Hand (RH)

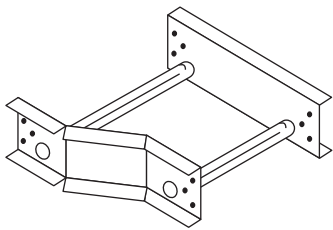

LEFT HAND (LH)

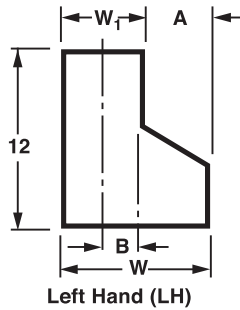

Left Hand (LH)

CSA CERTIFIED FOR CSA SYSTEMS

W Width	"W1" Dimension	"A" Dimension	"B" Dimension	Part Number
48" (1219mm)	42" (1067mm)	6" (152mm)	21" (533mm)	XXX-48(LH/RH)-42
	36" (914mm)	12" (305mm)	18" (457mm)	XXX-48(LH/RH)-36
	30" (762mm)	18" (457mm)	15" (381mm)	XXX-48(LH/RH)-30
	24" (610mm)	24" (610mm)	12" (305mm)	XXX-48(LH/RH)-24
	18" (457mm)	30" (762mm)	9" (229mm)	XXX-48(LH/RH)-18
	12" (305mm)	36" (914mm)	6" (152mm)	XXX-48(LH/RH)-12
	9" (229mm)	39" (991mm)	4½" (114mm)	XXX-48(LH/RH)-09
	6" (152mm)	42" (1067mm)	3" (76mm)	XXX-48(LH/RH)-06
42" (1067mm)	36" (914mm)	6" (152mm)	18" (457mm)	XXX-42(LH/RH)-36
	30" (762mm)	12" (305mm)	15" (381mm)	XXX-42(LH/RH)-30
	24" (610mm)	18" (457mm)	12" (305mm)	XXX-42(LH/RH)-24
	18" (457mm)	24" (610mm)	9" (229mm)	XXX-42(LH/RH)-18
	12" (305mm)	30" (762mm)	6" (152mm)	XXX-42(LH/RH)-12
	9" (229mm)	33" (838mm)	4½" (114mm)	XXX-42(LH/RH)-09
	6" (152mm)	36" (914mm)	3" (76mm)	XXX-42(LH/RH)-06
36" (914mm)	30" (762mm)	6" (152mm)	15" (381mm)	XXX-36(LH/RH)-30
	24" (610mm)	12" (305mm)	12" (305mm)	XXX-36(LH/RH)-24
	18" (457mm)	18" (457mm)	9" (229mm)	XXX-36(LH/RH)-18
	12" (305mm)	24" (610mm)	6" (152mm)	XXX-36(LH/RH)-12
	9" (229mm)	27" (686mm)	4½" (114mm)	XXX-36(LH/RH)-09
	6" (152mm)	30" (762mm)	3" (76mm)	XXX-36(LH/RH)-06
30" (762mm)	24" (610mm)	6" (152mm)	12" (305mm)	XXX-30(LH/RH)-24
	18" (457mm)	12" (305mm)	9" (229mm)	XXX-30(LH/RH)-18
	12" (305mm)	18" (457mm)	6" (152mm)	XXX-30(LH/RH)-12
	9" (229mm)	21" (533mm)	4½" (114mm)	XXX-30(LH/RH)-09
	6" (152mm)	24" (610mm)	3" (76mm)	XXX-30(LH/RH)-06
24" (610mm)	18" (457mm)	6" (152mm)	9" (229mm)	XXX-24(LH/RH)-18
	12" (305mm)	12" (305mm)	6" (152mm)	XXX-24(LH/RH)-12
	9" (229mm)	15" (381mm)	4½" (114mm)	XXX-24(LH/RH)-09
	6" (152mm)	18" (457mm)	3" (76mm)	XXX-24(LH/RH)-06
18" (457mm)	12" (305mm)	6" (152mm)	6" (152mm)	XXX-18(LH/RH)-12
	9" (229mm)	9" (229mm)	4½" (114mm)	XXX-18(LH/RH)-09
	6" (152mm)	12" (305mm)	3" (76mm)	XXX-18(LH/RH)-06
12" (305mm)	9" (229mm)	3" (76mm)	4½" (114mm)	XXX-12(LH/RH)-09
	6" (152mm)	6" (152mm)	3" (76mm)	XXX-12(LH/RH)-06
9" (229mm)	6" (152mm)	3" (76mm)	3" (76mm)	XXX-09(LH/RH)-06

Example: 238-12LH-06

Note: Nominal 9" rung spacing maintained through centerline of all fittings.

See Page 50
for Electrical
Grounding Chart

STRAIGHT REDUCER [ST]

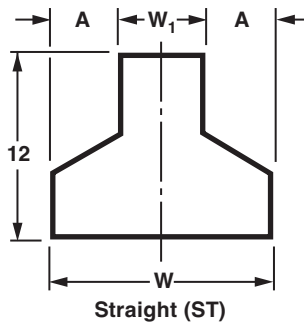
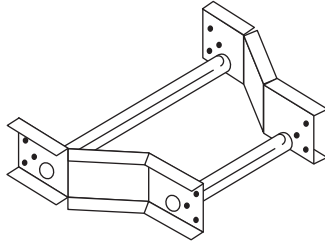

CSA CERTIFIED FOR CSA SYSTEMS

W Width	Width W1	"A" Dimension	Part Number
48" (1219mm)	42" (1067mm)	3" (76mm)	XXX-48ST-42
	36" (914mm)	6" (152mm)	XXX-48ST-36
	30" (762mm)	9" (229mm)	XXX-48ST-30
	24" (610mm)	12" (w305mm)	XXX-48ST-24
	18" (457mm)	15" (381mm)	XXX-48ST-18
	12" (305mm)	18" (457mm)	XXX-48ST-12
	9" (229mm)	19½" (495mm)	XXX-48ST-09
	6" (152mm)	21" (533mm)	XXX-48ST-06
42" (1067mm)	36" (914mm)	3" (76mm)	XXX-42ST-36
	30" (762mm)	6" (152mm)	XXX-42ST-30
	24" (610mm)	9" (229mm)	XXX-42ST-24
	18" (457mm)	12" (305mm)	XXX-42ST-18
	12" (305mm)	15" (381mm)	XXX-42ST-12
	9" (229mm)	16½" (419mm)	XXX-42ST-09
36" (914mm)	30" (762mm)	3" (76mm)	XXX-36ST-30
	24" (610mm)	6" (152mm)	XXX-36ST-24
	18" (457mm)	9" (229mm)	XXX-36ST-18
	12" (305mm)	12" (305mm)	XXX-36ST-12
	9" (229mm)	13½" (343mm)	XXX-36ST-09
	6" (152mm)	15" (381mm)	XXX-36ST-06
30" (762mm)	24" (610mm)	3" (76mm)	XXX-30ST-24
	18" (457mm)	6" (152mm)	XXX-30ST-18
	12" (305mm)	9" (229mm)	XXX-30ST-12
	9" (229mm)	10½" (267mm)	XXX-30ST-09
	6" (152mm)	12" (304mm)	XXX-30ST-06
24" (610mm)	18" (457mm)	3" (76mm)	XXX-24ST-18
	12" (305mm)	6" (152mm)	XXX-24ST-12
	9" (229mm)	7½" (191mm)	XXX-24ST-09
	6" (152mm)	9" (229mm)	XXX-24ST-06
18" (457mm)	12" (305mm)	3" (76mm)	XXX-18ST-12
	9" (229mm)	4½" (114mm)	XXX-18ST-09
	6" (152mm)	6" (152mm)	XXX-18ST-06
12" (305mm)	9" (229mm)	1½" (38mm)	XXX-12ST-09
	6" (152mm)	3" (76mm)	XXX-12ST-06
9" (229mm)	6" (152mm)	1½" (38mm)	XXX-09ST-06

Example: 238-12ST-06

Note: Nominal 9" rung spacing maintained through centerline of all fittings.

See Page 50
for Electrical
Grounding Chart

LADDER CABLE TRAY SYSTEM

45° "Y" BRANCH LEFT HAND [LY] & RIGHT HAND [RY]

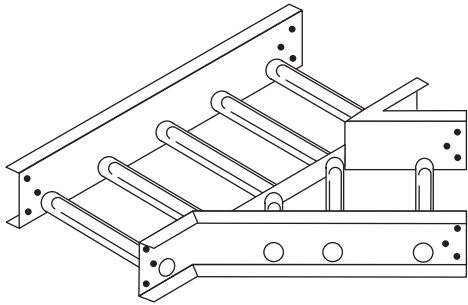

RIGHT HAND (RY) SHOWN

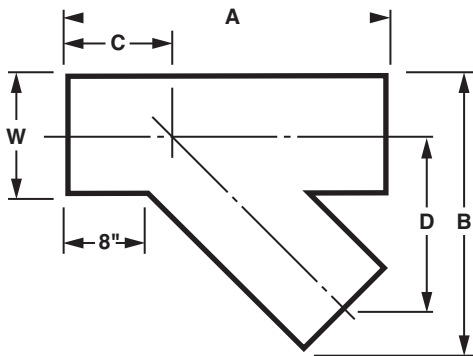

W Width	"A" Dimension	"B" Dimension	"C" Dimension	"D" Dimension	Part Number
6" (152mm)	22½" (571mm)	16¼" (413mm)	9¼" (235mm)	11⅞" (283mm)	XXX-06(LY/R)
9" (229mm)	26¾" (679mm)	21⅜" (543mm)	9⅝" (249mm)	13¾" (349mm)	XXX-09(LY/R)
12" (305mm)	31" (787mm)	26½" (673mm)	10½" (267mm)	16¼" (412mm)	XXX-12(LY/R)
18" (457mm)	39½" (1003mm)	36¾" (933mm)	11¾" (298mm)	21⅝" (543mm)	XXX-18(LY/R)
24" (610mm)	48" (1219mm)	47" (1193mm)	13" (330mm)	26½" (673mm)	XXX-24(LY/R)
30" (762mm)	56¾" (1432mm)	57¼" (1454mm)	14½" (359mm)	31⅝" (803mm)	XXX-30(LY/R)
36" (914mm)	65" (1651mm)	67½" (1714mm)	15½" (394mm)	36¾" (933mm)	XXX-36(LY/R)
42" (1067mm)	73⅝" (1864mm)	77⅝" (1972mm)	16¾" (425mm)	41¾" (1060mm)	XXX-42(LY/R)
48" (1219mm)	81⅞" (2080mm)	87⅞" (2232mm)	18" (457mm)	46⅞" (1191mm)	XXX-48(LY/R)

Example: 238-12LY

Note: Nominal 9" rung spacing maintained through centerline of all fittings.

ADJUSTABLE ELBOW [AF]

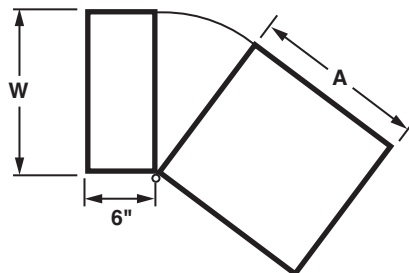
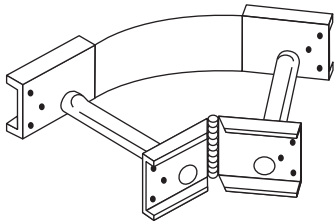

W Width	"A" Dimension	Part Number
6" (152mm)	8" (203mm)	XXX-06AF
9" (229mm)	11" (279mm)	XXX-09AF
12" (305mm)	14" (356mm)	XXX-12AF
18" (457mm)	20" (508mm)	XXX-18AF
24" (610mm)	26" (660mm)	XXX-24AF
30" (762mm)	32" (813mm)	XXX-30AF
36" (914mm)	38" (965mm)	XXX-36AF
42" (1067mm)	44" (1118mm)	XXX-42AF
48" (1219mm)	50" (1270mm)	XXX-48AF

Example: 238-12AF

See Page 50
for Electrical
Grounding Chart

90° VERTICAL ELBOW OUTSIDE [90] & INSIDE [9I]

CSA CERTIFIED FOR CSA SYSTEMS

Radius - R	"H" Dimension	"A" Dimension	"B" Dimension	"C" Dimension	Part Number
12" (305mm)	4¼" (108mm)	12¼" (311mm)	7⅞" (181mm)	14⅞" (359mm)	X3X-XX(90/9I)-12
	5¼" (133mm)	12⅝" (321mm)	7¾" (187mm)	14⅝" (372mm)	X4X-XX(90/9I)-12
	6¼" (159mm)	13⅞" (334mm)	7⅝" (194mm)	15⅞" (384mm)	X5X-XX(90/9I)-12
	7¼" (184mm)	13½" (343mm)	7⅞" (200mm)	15⅝" (397mm)	X6X-XX(90/9I)-12
24" (610mm)	4¼" (108mm)	22⅝" (575mm)	13⅞" (334mm)	26⅞" (664mm)	X3X-XX(90/9I)-24
	5¼" (133mm)	23⅞" (588mm)	13¾" (340mm)	26⅝" (676mm)	X4X-XX(90/9I)-24
	6¼" (159mm)	231/2" (597mm)	13" (330mm)	27⅞" (689mm)	X5X-XX(90/9I)-24
	7¼" (184mm)	24" (610mm)	1⅞" (353mm)	27⅝" (702mm)	X6X-XX(90/9I)-24
36" (914mm)	4¼" (108mm)	33" (838mm)	19⅞" (486mm)	38⅞" (969mm)	X3X-XX(90/9I)-36
	5¼" (133mm)	33½" (851mm)	19¾" (492mm)	38⅝" (981mm)	X4X-XX(90/9I)-36
	6¼" (159mm)	33⅞" (861mm)	19⅝" (499mm)	39⅞" (994mm)	X5X-XX(90/9I)-36
	7¼" (184mm)	34⅞" (873mm)	19⅞" (505mm)	39⅝" (1007mm)	X6X-XX(90/9I)-36

Example: 238-1290-12

Note: Use Adjustable Connectors for odd angles. Nominal 9" rung spacing maintained through centerline of all fittings.

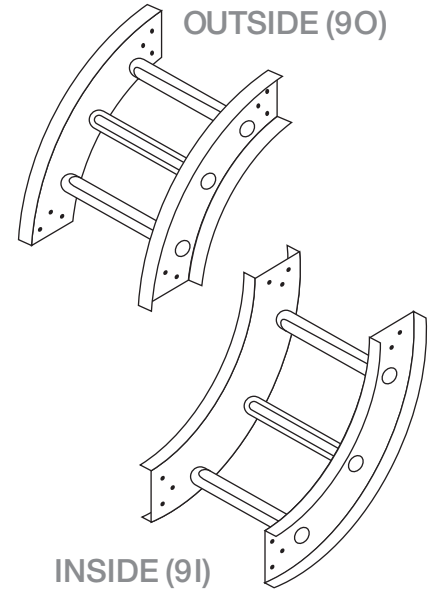
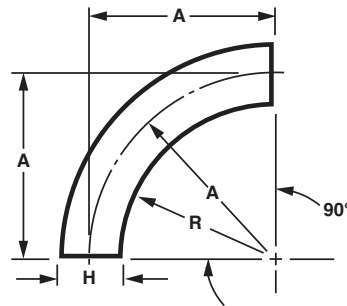

60° VERTICAL ELBOW OUTSIDE [60] & INSIDE [6I]

CSA CERTIFIED FOR CSA SYSTEMS

Radius - R	"H" Height	"A" Dimension	Part Number
12" (305mm)	4¼" (108mm)	14⅞" (359mm)	X3X-XX(60/6I)-12
	5¼" (133mm)	14⅝" (372mm)	X4X-XX(60/6I)-12
	6¼" (159mm)	15⅞" (384mm)	X5X-XX(60/6I)-12
	7¼" (184mm)	15⅝" (397mm)	X6X-XX(60/6I)-12
24" (610mm)	4¼" (108mm)	26⅞" (664mm)	X3X-XX(60/6I)-24
	5¼" (133mm)	26⅝" (676mm)	X4X-XX(60/6I)-24
	6¼" (159mm)	27⅞" (689mm)	X5X-XX(60/6I)-24
	7¼" (184mm)	27⅝" (702mm)	X6X-XX(60/6I)-24
36" (914mm)	4¼" (108mm)	38⅞" (969mm)	X3X-XX(60/6I)-36
	5¼" (133mm)	38⅝" (981mm)	X4X-XX(60/6I)-36
	6¼" (159mm)	39⅞" (994mm)	X5X-XX(60/6I)-36
	7¼" (184mm)	39⅝" (1007mm)	X6X-XX(60/6I)-36

Example: 238-1260-12

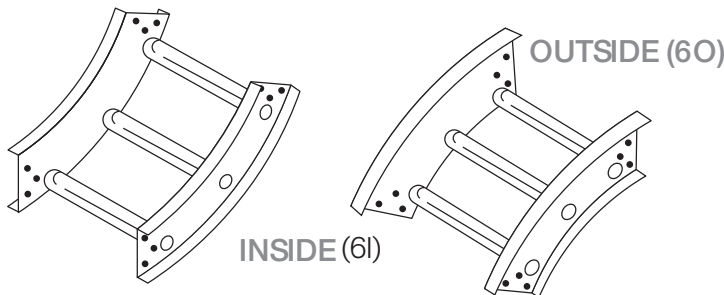
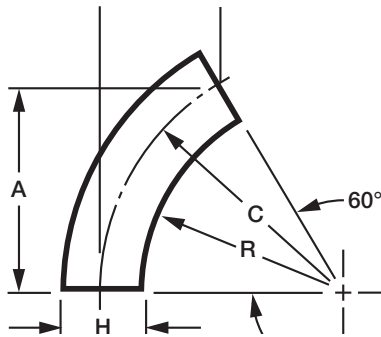

See Page 50
for Electrical
Grounding Chart

LADDER CABLE TRAY SYSTEM

45° VERTICAL ELBOW OUTSIDE [40] & INSIDE [41]

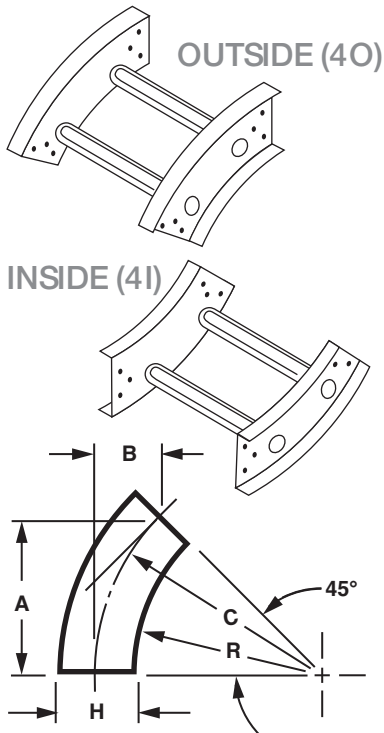

CSA CERTIFIED FOR CSA SYSTEMS

Radius - R	"H" Dimension	"A" Dimension	"B" Dimension	"C" Dimension	Part Number
12" (305mm)	4¼" (108mm)	10" (254mm)	4½" (105mm)	14⅝" (359mm)	X3X-XX(40/4)-12
	5¼" (133mm)	10⅞" (264mm)	4¼" (108mm)	14⅝" (372mm)	X4X-XX(40/4)-12
	6¼" (159mm)	10¾" (273mm)	4½" (114mm)	15⅝" (384mm)	X5X-XX(40/4)-12
	7¼" (184mm)	11⅞" (283mm)	4⅝" (118mm)	15⅝" (397mm)	X6X-XX(40/4)-12
24" (610mm)	4¼" (108mm)	18½" (470mm)	7⅞" (194mm)	26⅞" (664mm)	X3X-XX(40/4)-24
	5¼" (133mm)	18⅞" (480mm)	7⅞" (200mm)	26⅞" (676mm)	X4X-XX(40/4)-24
	6¼" (159mm)	19¼" (489mm)	8" (203mm)	27⅞" (689mm)	X5X-XX(40/4)-24
	7¼" (184mm)	19½" (495mm)	8⅞" (207mm)	27⅞" (702mm)	X6X-XX(40/4)-24
36"(914mm)	4¼" (108mm)	27" (686mm)	11⅞" (283mm)	38⅞" (969mm)	X3X-XX(40/4)-36
	5¼" (133mm)	27⅞" (695mm)	11⅞" (289mm)	38⅞" (981mm)	X4X-XX(40/4)-36
	6¼" (159mm)	27⅞" (702mm)	11½" (292mm)	39⅞" (994mm)	X5X-XX(40/4)-36
	7¼" (184mm)	8" (711mm)	11⅞" (295mm)	39⅞" (1007mm)	X6X-XX(40/4)-36

Example: 238-1240-12

Note: Use Adjustable Connectors for odd angles. Nominal 9" rung spacing maintained through centerline of all fittings.

30° VERTICAL ELBOW OUTSIDE [30] & INSIDE [31]

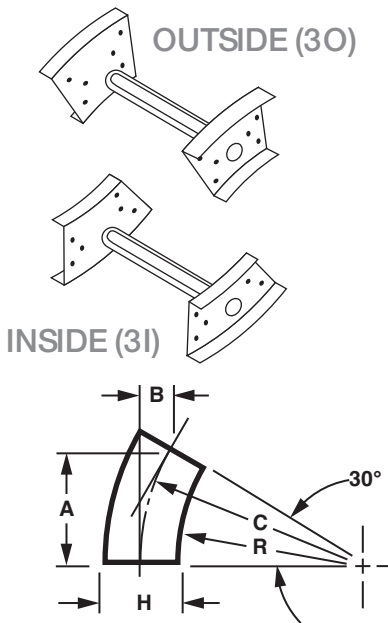

CSA CERTIFIED FOR CSA SYSTEMS

Radius - R	"H" Dimension	"A" Dimension	"B" Dimension	"C" Dimension	Part Number
12" (305mm)	4¼" (108mm)	7⅞" (181mm)	1⅞" (48mm)	14⅝" (359mm)	X3X-XX(30/3)-12
	5¼" (133mm)	7⅞" (187mm)	2" (51mm)	14⅝" (372mm)	X4X-XX(30/3)-12
	6¼" (159mm)	7⅞" (194mm)	2" (51mm)	15⅝" (384mm)	X5X-XX(30/3)-12
	7¼" (184mm)	7⅞" (200mm)	2⅞" (54mm)	15⅝" (397mm)	X6X-XX(30/3)-12
24" (610mm)	4¼" (108mm)	13⅞" (334mm)	3½" (89mm)	26⅞" (664mm)	X3X-XX(30/3)-24
	5¼" (133mm)	13⅞" (340mm)	3⅞" (92mm)	26⅞" (676mm)	X4X-XX(30/3)-24
	6¼" (159mm)	13⅞" (346mm)	3⅞" (92mm)	27⅞" (689mm)	X5X-XX(30/3)-24
	7¼" (184mm)	13⅞" (353mm)	3¾" (95mm)	27⅞" (702mm)	X6X-XX(30/3)-24
36" (914mm)	4¼" (108mm)	19⅞" (486mm)	5⅞" (130mm)	38⅞" (969mm)	X3X-XX(30/3)-36
	5¼" (133mm)	19⅞" (492mm)	5¼" (133mm)	38⅞" (981mm)	X4X-XX(30/3)-36
	6¼" (159mm)	19⅞" (499mm)	5¼" (133mm)	39⅞" (994mm)	X5X-XX(30/3)-36
	7¼" (184mm)	19⅞" (505mm)	5⅞" (137mm)	39⅞" (1007mm)	X6X-XX(30/3)-36

Example: 238-1230-12

See Page 50
for Electrical
Grounding Chart

90° VERTICAL CABLE SUPPORT ELBOW [SR]

CSA CERTIFIED FOR CSA SYSTEMS

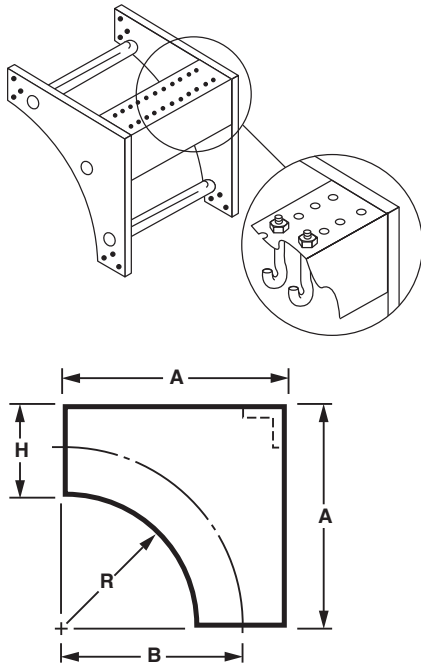

Radius - R	"H" Dimension	"A" Dimension	"B" Dimension	"C" Dimension	Part Number
12" (305mm)	4¼" (108mm)	28¼" (718mm)	16¼" (413mm)	14⅝" (359mm)	X3X-XXSR-12
	5¼" (133mm)	29¼" (743mm)	17¼" (438mm)	14⅝" (371mm)	X4X-XXSR-12
	6¼" (159mm)	30¼" (768mm)	18¼" (464mm)	15⅝" (384mm)	X5X-XXSR-12
	7¼" (814mm)	31¼" (794mm)	19¼" (489mm)	15⅝" (397mm)	X6X-XXSR-12
24" (610mm)	4¼" (108mm)	52¼" (1327mm)	28¼" (718mm)	26⅝" (664mm)	X3X-XXSR-24
	5¼" (133mm)	53¼" (1353mm)	29¼" (743mm)	26⅝" (676mm)	X4X-XXSR-24
	6¼" (159mm)	54¼" (1378mm)	30¼" (768mm)	27⅝" (689mm)	X5X-XXSR-24
	7¼" (814mm)	55¼" (1403mm)	31¼" (794mm)	27⅝" (702mm)	X6X-XXSR-24
36" (914mm)	4¼" (108mm)	76¼" (1937mm)	40¼" (1022mm)	38⅝" (968mm)	X3X-XXSR-36
	5¼" (133mm)	77¼" (1962mm)	41¼" (1048mm)	38⅝" (981mm)	X4X-XXSR-36
	6¼" (159mm)	78¼" (1988mm)	42¼" (1073mm)	39⅝" (994mm)	X5X-XXSR-36
	7¼" (814mm)	79¼" (2013mm)	43¼" (1099mm)	39⅝" (1006mm)	X6X-XXSR-36

Example: 238-12SR-12

Note: Use Adjustable Connectors for odd angles. Nominal 9" rung spacing maintained through centerline of all fittings.

VERTICAL TEE - DOWN [VT] & UP [OT]

CSA CERTIFIED FOR CSA SYSTEMS

VERTICAL TEE (VT)

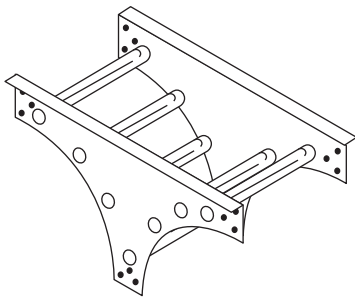

VERTICAL TEE - UP (OT)

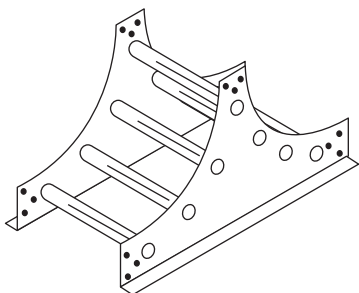

Radius - R	"H" Dimension	"A" Dimension	"B" Dimension	Part Number
12" (305mm)	4¼" (108mm)	16¼" (413mm)	14⅝" (359mm)	X3X-XX(VT/VO)-12
	5¼" (133mm)	17¼" (438mm)	14⅝" (371mm)	X4X-XX(VT/VO)-12
	6¼" (159mm)	18¼" (464mm)	15⅝" (384mm)	X5X-XX(VT/VO)-12
	7¼" (814mm)	19¼" (489mm)	15⅝" (397mm)	X6X-XX(VT/VO)-12
24" (610mm)	4¼" (108mm)	28¼" (718mm)	26⅝" (664mm)	X3X-XX(VT/VO)-24
	5¼" (133mm)	29¼" (743mm)	26⅝" (676mm)	X4X-XX(VT/VO)-24
	6¼" (159mm)	30¼" (768mm)	27⅝" (689mm)	X5X-XX(VT/VO)-24
	7¼" (814mm)	31¼" (794mm)	27⅝" (702mm)	X6X-XX(VT/VO)-24
36" (914mm)	4¼" (108mm)	40¼" (1022mm)	38⅝" (968mm)	X3X-XX(VT/VO)-36
	5¼" (133mm)	41¼" (1048mm)	38⅝" (981mm)	X4X-XX(VT/VO)-36
	6¼" (159mm)	42¼" (1073mm)	39⅝" (994mm)	X5X-XX(VT/VO)-36
	7¼" (814mm)	43¼" (1099mm)	39⅝" (1006mm)	X6X-XX(VT/VO)-36

Example: 238-12VT-12

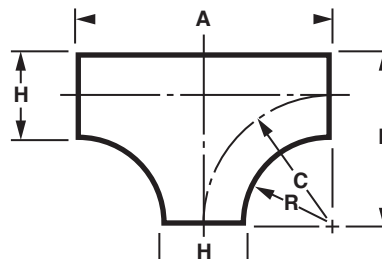

See Page 50
for Electrical
Grounding Chart

LADDER CABLE TRAY SYSTEM

ELECTRICAL GROUNDING CHART

Table 1 below provides the Minimum Cross Sectional area for two side rails. Using the Fitting Prefix Number (248), the proper value is determined by the Material (column 3), the Flange Width (column 1), and Load Depth (column 2). Locate the line containing the Load Depth (column 1) and follow it to the right to the appropriate Flange Width and Material.

TABLE 1

			Min. X-Sect for 2 Rails (NEC® Table 392.7B)			
			Aluminum		Steel	
Fitting Prefix Number			¹³ / ₁₆ " Flange	1 ¹ / ₄ " Flange	¹³ / ₁₆ " Flange	1 ¹ / ₄ " Flange
Flange	Load Depth	Material	X-Sect Area	X-Sect Area	X-Sect Area	X-Sect Area
2 - ¹³ / ₁₆ "	3"	6 - Mill Gal	0.60	0.60	0.40	0.70
4 - 1 ¹ / ₄ "	4"	7 - HDGAF	0.60	0.60	0.40	0.70
	5"	8 - Alum.	0.60	1.00	0.70	0.70
	6"		0.60	1.00	0.70	1.00

Find that value in Table 2, follow it to the right to the Material column to determine the Maximum Ground Fault Amperage.

TABLE 2

X-Sect Area	Maximum Ground Fault Amperage (in Amps)	
	Aluminum	Steel
.40 sq in	-	100
.60 sq in	1000	-
.70 sq in	-	200
1.00 sq in	1200	400

For Example:

If the fitting prefix is 248, the Flange is ¹³/₁₆" the Load Depth is 4", and the Material is Aluminum. The Minimum Cross Sectional Area (X-Sect Area) is 0.60 sq. in. The Amperage is 1000.

TYPICAL SPECIFICATIONS

By specifying the NEMA class designation, you will use the simplest, clearest, and most complete method of specification available and automatically incorporate support span in feet, working (allowable) load in pounds per linear foot, a safety factor of 1.5, a concentrated load, if present; and, all other design, manufacturing, and test standards including electrical continuity.

All you need to do is add the desired load depth, rung spacing, radius of fittings, metal, and finish. You may add accessory information pursuant to your project. Here is a typical specification for an outdoor tray system where the working (allowable) load has been determined to be approximately 75 pounds per foot on support spans of 12'-0".

SPECIFICATION ALUMINUM COPE LADDER SYSTEM

Cable Ladder shall be manufactured by a company regularly engaged in the manufacture of metal cable trays and shall be a member of NEMA. Trays shall conform to NEMA Metal Cable Tray Standard Publication VE-1 (latest issue).

1. Cable ladder shall be NEMA Classification 12B of the widths indicated.
2. Material shall be aluminum alloy with side rails and rungs of 6063.
3. Finish shall be natural.
4. Inside load depth to be NEMA Standard 3".
5. Fittings shall be 12" radius for control cables and 24" radius for power cables. (This must be commensurate with the cable manufacturer's recommended minimum bending radius.)
6. All top level trays in stacks and single runs to have raised, peaked aluminum ventilated covers with heavy duty hold down clamps every 3'-0".
7. Install expansion connectors, expansion guides, and hold down clamps per NEMA Standard VE-1

8. Where slopes or horizontal bends of trays are not at the Standard NEMA angles, use adjustable connectors. If the angle is too great for cable bending radius, use combinations of fitting and adjustable connectors.

9. Separate all cables of different volt ages in the same tray using the manufacturer's standard barriers and barrier hold down system.

10. The Cable Ladder system will be used as an equipment grounding conductor.

11. To save space fittings shall have no tangents. To facilitate field installation, use one pair of universal type connector plates for rigid joints.

12. Cable Ladder shall have outward facing side rails with tubular rungs assembled into side rails by cold swaging. Cable support surface on top of rungs to be flattened. Inside of tray shall not have flanges or other projections. Full access to the contents of the Cable Ladder shall be available.

13. Trays shall be Cope Cable Ladder System Number 3B38 as manufactured by Atkore International.

4



HAT



Economical Flange in Welded Cable Ladder/Trof System for Electrical, Telephone, Computer Control & Instrumentation Cable

Slotted Rungs provided on trays 6", 9", 12", 18" and 24" wide.
Solid Rungs provided on trays 30" and 36" wide.

CONTENTS

GENERAL & TECHNICAL INFORMATION

Selection Chart: Cope Hat - Aluminum	54 - 55
Selection Chart: Cope Hat - Steel.....	56 - 57
Overview	58 - 59
Ordering Information.....	60
Straight Length.....	61

COPE HAT FITTINGS

Horizontal Elbows	
90°	62
60°	62
45°	63
30°	63
Horizontal Tee	64, 66
Horizontal Cross.....	65, 67 - 68
Straight Reducers	69
Left and Right Hand Reducers	69
Adjustable Elbow	70
45° "Y" Branch	70
Vertical Elbows (Inside and Outside)	
90°	71
60°	71
45°	72
30°	72
90° Vertical Cable Support Elbow	73
Vertical Tee.....	73
Electrical Grounding Chart.....	74
Typical Specification.....	74

STRAIGHT LENGTH

Page 61

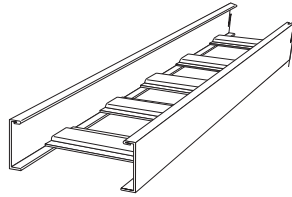

ADJUSTABLE ELBOWS

Page 70

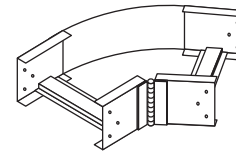

HORIZONTAL ELBOWS

Pages 62 - 63

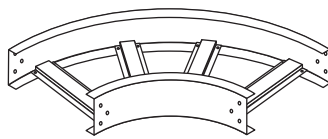

45° "Y" BRANCH

Page 70

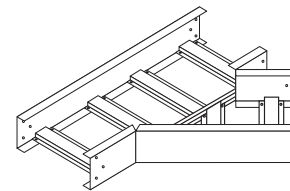

HORIZONTAL TEE

Pages 64, 66

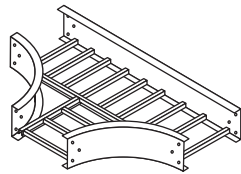

VERTICAL ELBOWS

Pages 71 - 72

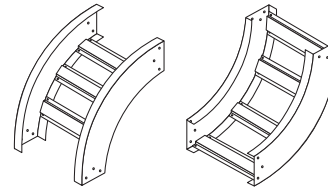

HORIZONTAL CROSS

Pages 65, 67 - 68

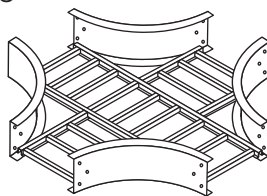

90° VERTICAL CABLE SUPPORT ELBOW

Page 73

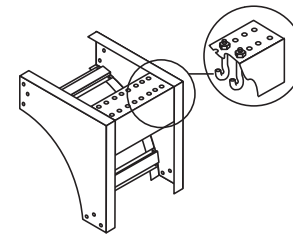

REDUCERS

Page 69

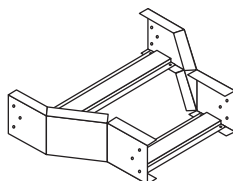

VERTICAL TEE

Page 73

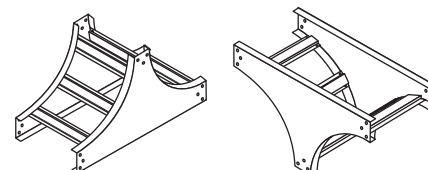

HAT CABLE TRAY SYSTEM

ALUMINUM TRAY

SELECTION CHART

NEMA CLASS, PHYSICAL AND STRUCTURAL PROPERTIES

NEMA Standard VE-1 Load/Span Class	Cope System Number	Nominal Load Depth	Side Rail Height		Flange Width (in.)		Section Modulus of 2 Rails Sx (in.3)	Moment of Inertia for 2 Rails Ix (in.4)	Min X-Sect. Area of 2 Rails per NEC 392.7 (in.2)
8A-12A 50 lb./ft. 12' span	523A	3"	(76mm)	3½"	(89mm)	13/16"	0.800	1.400	0.6
	1B4A	4"	(102mm)	4¼"	(108mm)	13/16"	1.898	1.822	0.6
	1B5A	5"	(127mm)	5¼"	(133mm)	13/16"	1.142	2.872	0.6
	3B6A	6"	(152mm)	6¼"	(159mm)	13/16"	1.614	4.720	1.0
12B 12' span	3B4A	4"	(102mm)	4¼"	(108mm)	13/16"	1.148	2.316	0.6
	1B5A	5"	(127mm)	5¼"	(133mm)	13/16"	1.142	2.872	0.6
	3B6A	6"	(152mm)	6¼"	(159mm)	13/16"	1.614	4.720	0.6
12C 100 lb./ft. 12' span	5B4A	4"	(102mm)	4¼"	(108mm)	13/16"	1.646	3.058	1.0
	3B5A	5"	(127mm)	5¼"	(133mm)	13/16"	1.522	3.734	1.0
	5B6A	6"	(152mm)	6¼"	(159mm)	13/16"	1.944	5.866	1.0
16A 50 lb./ft. 16' span	5B4A	4"	(102mm)	4¼"	(108mm)	13/16"	1.646	3.058	1.0
	745A	5"	(127mm)	5¼"	(133mm)	1¼"	2.396	6.292	1.5
	1D6A	6"	(152mm)	6¼"	(159mm)	1¼"	2.378	7.202	1.0
16B 75 lb./ft. 16' span	3D4A	4"	(102mm)	4¼"	(108mm)	1¼"	2.242	4.406	1.0
	745A	5"	(127mm)	5¼"	(133mm)	1¼"	2.396	6.292	1.5
	1D6A	6"	(152mm)	6¼"	(159mm)	1¼"	2.378	7.202	1.0
16C 100 lb./ft. 16' span	5D4A	4"	(102mm)	4¼"	(108mm)	1¼"	2.782	5.738	1.5
	3D5A	5"	(127mm)	5¼"	(133mm)	1¼"	3.434	8.746	2.0
	7D6A	6"	(152mm)	6¼"	(159mm)	1¼"	4.186	12.024	2.0
20A 50 lb./ft. 20' span	3D4A	4"	(102mm)	4¼"	(108mm)	1¼"	2.242	4.406	1.0
	745A	5"	(127mm)	5¼"	(133mm)	1¼"	2.396	6.292	1.5
	1D6A	6"	(152mm)	6¼"	(159mm)	1¼"	2.378	7.202	1.0
20B 75 lb./ft. 20' span	3D5A	5"	(127mm)	5¼"	(133mm)	1¼"	3.434	8.746	2.0
	7D6A	6"	(152mm)	6¼"	(159mm)	1¼"	4.186	12.024	2.0
20C 100 lb./ft. 20' span	5D5A	5"	(127mm)	5¼"	(108mm)	1¼"	3.910	10.020	2.0
	7D6A	6"	(152mm)	6¼"	(133mm)	1¼"	4.186	12.024	2.0
EXTRA HEAVY DUTY - VERY LONG SPAN TRAYS- 4", 6" OR 9" RUNG SPACING									
	9D6A	6"	(152mm)	6¼"	(159mm)	1¼"	5.130	15.700	2.0
	7G6A	6"	(152mm)	6¼"	(159mm)	2"	5.804	17.456	2.0

Note: Indicates most common systems. Consult factory for lead times on other systems.

Slotted Rungs provided on trays 6", 9", 12", 18" and 24" wide.

Solid Rungs provided on trays 30" and 36" wide.

**LOAD AND DEFLECTION DATA FOR ALUMINUM HAT WORKING (ALLOWABLE) LOAD CAPACITY,
EVENLY DISTRIBUTED-TESTED PER NEMA STANDARD VE-1,
SIMPLE BEAM - SAFETY FACTOR 1.5**

Cope Sys. No.	6 Ft. Span			8 Ft. Span			10 Ft. Span			12 Ft. Span			16 Ft. Span			20 Ft. Span			24 Ft. Span			25 Ft. Span		
	w	d	k	w	d	k	w	d	k	w	d	k	w	d	k	w	d	k	w	d	k	w	d	k
523A	207	0.43	0.002	117	0.77	0.007	75	1.20	0.016	52	1.73	0.033												
1B4A	222	0.35	0.002	125	0.63	0.005	80	0.99	0.012	55	1.42	0.026												
1B5A	324	0.33	0.001	182	0.59	0.003	117	0.87	0.007	77	1.26	0.016												
3B6A	359	0.22	†	191	0.37	0.002	115	0.55	0.005	75	74.00	0.010												
3B4A	354	0.45	0.001	191	0.76	0.004	117	1.14	0.010	78	1.57	0.020												
1B5A	324	0.33	0.001	182	0.59	0.003	117	0.87	0.007	77	1.26	0.016												
3B6A	359	0.22	†	191	0.37	0.002	115	0.55	0.005	75	0.74	0.010												
5B4A	362	0.32	†	251	0.69	0.003	161	1.08	0.007	112	1.55	0.014												
3B5A	394	0.31	†	222	0.55	0.002	142	0.86	0.006	100	1.24	0.012												
5B6A	480	0.24	†	257	0.40	0.002	156	0.60	0.004	102	0.81	0.008												
5B4A				251	0.69	0.003	161	1.08	0.007	112	1.55	0.014	51	2.26	0.044	25	2.75	0.110						
745A				349	0.51	0.001	223	0.80	0.004	155	1.15	0.007	79	1.85	0.023	51	2.89	0.057						
1D6A				380	0.49	0.001	222	0.69	0.003	154	1.00	0.006	78	1.61	0.021	50	2.51	0.050						
3D4A				342	0.72	0.002	219	1.12	0.005	152	1.61	0.011	82	2.74	0.033	52	4.27	0.082						
745A				349	0.51	0.001	223	0.80	0.004	155	1.15	0.007	79	1.85	0.023	51	2.89	0.057						
1D6A				380	0.49	0.001	222	0.69	0.003	154	1.00	0.006	78	1.61	0.021	50	2.51	0.050						
5D4A				444	0.71	0.002	284	0.70	0.002	188	1.53	0.008	106	2.73	0.026	65	4.07	0.063						
3D5A				525	0.55	0.001	336	0.86	0.003	233	1.24	0.005	119	2.01	0.017	76	3.14	0.041						
7D6A										229	1.00	0.004	116	1.60	0.014	75	2.50	0.033						
3D4A										152	1.61	0.011	82	2.74	0.033	52	4.27	0.082						
745A										155	1.15	0.007	79	1.85	0.023	51	2.89	0.057						
1D6A										154	1.00	0.006	78	1.61	0.021	50	2.51	0.050						
3D5A										233	1.24	0.005	119	2.01	0.017	76	3.14	0.041						
7D6A										229	1.00	0.004	116	1.60	0.014	75	2.50	0.033						
5D5A										290	1.35	0.005	156	2.30	0.015	100	3.59	0.036						
7D6A										284	1.09	0.004	158	1.94	0.012	101	3.02	0.030						
9D6A										412	1.22	0.003	214	2.00	0.009	131	3.01	0.023	68	3.23	0.048			
7G6A										451	1.20	0.003	253	2.14	0.008	162	3.35	0.020	112	4.79	0.043	104	5.24	0.05

Note: To convert 1.5 safety factor to 2.0 multiply w,d,k by .75.

W=Pounds per linear foot

Metric: for kg/m multiply w by 1.48

d=Deflection (inches)

k= Deflection (in.) for each pound of load

†= Denotes k is less than .001 inch

HAT CABLE TRAY SYSTEM

STEEL TRAY

SELECTION CHART

NEMA CLASS, PHYSICAL AND STRUCTURAL PROPERTIES

NEMA Standard VE-1 Load/ Span Class	Mill Galv. System Number	HDGAF System Number	Type 304 SS System Number	Nominal Load Depth		Side Rail Height		Flange Width (in.)	Section Modulus of 2 Rails Sx (in.3)	Moment of Inertia for 2 Rails ix (in.4)	Min. X-Sect. Area of 2 Rails per NEC 392-7 (in.2)
8A-12A 50 lb./ft. 12' span	823P	623G	823S	3"	(76mm)	3½"	(89mm)	13/16"	0.444	0.778	0.4
	824P	624G	824S	4"	(102mm)	4¼"	(108mm)	13/16"	0.592	1.258	0.4
	825P	625G	825S	5"	(127mm)	5¼"	(133mm)	13/16"	0.816	2.142	0.4
	826P	626G	826S	6"	(152mm)	6¼"	(159mm)	13/16"	1.072	3.352	0.7
12B 75 lb./ft. 12' span	423P	423G	423S	3"	(76mm)	3½"	(89mm)	13/16"	0.674	1.180	0.7
	8B4P	6B4G	8B4S	4"	(102mm)	4¼"	(108mm)	13/16"	0.678	1.370	0.4
	825P	625G	825S	5"	(127mm)	5¼"	(133mm)	13/16"	0.816	2.142	0.4
	826P	626G	826S	6"	(152mm)	6¼"	(159mm)	13/16"	1.072	3.352	0.7
12C 100 lb./ft. 12' span	6B4P	6B4G	6B4S	4"	(102mm)	4¼"	(108mm)	13/16"	0.834	1.690	0.7
	6B5P	6B5G	6B5S	5"	(127mm)	5¼"	(133mm)	13/16"	1.140	2.872	0.7
	626P	626G	626S	6"	(152mm)	6¼"	(159mm)	13/16"	1.330	4.158	0.7
16A 50 lb./ft. 16' span	8D4P	6D4G	8D4S	4"	(102mm)	4¼"	(108mm)	13/16"	0.852	1.736	0.4
	645P	645G	645S	5"	(127mm)	5¼"	(133mm)	1¼"	1.280	3.360	0.7
	646P	646G	646S	6"	(152mm)	6¼"	(159mm)	1¼"	1.652	5.160	0.7
16B 75 lb./ft. 16' span	6D4P	6D4G	6D4S	4"	(102mm)	4¼"	(108mm)	1¼"	1.056	2.152	0.7
	645P	645G	645S	5"	(127mm)	5¼"	(133mm)	1¼"	1.280	3.360	0.7
	646P	646G	646S	6"	(152mm)	6¼"	(159mm)	1¼"	1.652	5.160	0.7
16C 100 lb./ft. 16' span	4D4P	4D4G	4D4S	4"	(102mm)	4¼"	(108mm)	1¼"	1.298	2.652	1.0
	645P	645G	645S	5"	(127mm)	5¼"	(133mm)	1¼"	1.280	3.360	0.7
	646P	646G	646S	6"	(152mm)	6¼"	(159mm)	1¼"	1.652	5.160	0.7
20A 50 lb./ft. 20' span	6D4P	6D4G	6D4S	4"	(102mm)	4¼"	(108mm)	1¼"	1.056	2.152	0.7
	645P	645G	645S	5"	(127mm)	5¼"	(133mm)	1¼"	1.280	3.360	0.7
	646P	646G	646S	6"	(152mm)	6¼"	(159mm)	1¼"	1.652	5.160	1.0
20B 75 lb./ft. 20' span	2D4P	2D4G	2D4S	4"	(102mm)	4¼"	(108mm)	1¼"	1.758	3.604	1.0
	4D5P	4D5G	4D5S	5"	(127mm)	5¼"	(133mm)	1¼"	1.744	4.418	1.0
	6D6P	6D6G	6D6S	6"	(152mm)	6¼"	(159mm)	1¼"	1.814	5.486	1.0
20C 100 lb./ft. 20' span	2D5P	2D5G	2D5S	5"	(127mm)	5¼"	(133mm)	1¼"	2.370	6.026	1.5
	4D6P	4D6G	4D6S	6"	(143mm)	6¼"	(159mm)	1¼"	2.240	6.778	1.0
EXTRA HEAVY DUTY - VERY LONG SPAN TRAYS- 4", 6" OR 9" RUNG SPACING											
	2D6P	2D6G	2D6S	6"	(152mm)	6¼"	(159mm)	1¼"	3.052	9.270	1.5
	11D6P	11D6G	11D6S	6"	(152mm)	6¼"	(159mm)	1¼"	3.536	10.630	1.5

Note: indicates most common systems. Consult factory for lead times on other systems.
Slotted Rungs provided on trays 6", 9", 12", 18" and 24" wide.
Solid Rungs provided on trays 30" and 36" wide.

**LOAD AND DEFLECTION DATA FOR STEEL HAT
WORKING (ALLOWABLE) LOAD CAPACITY, EVENLY DISTRIBUTED-TESTED PER NEMA STANDARD VE-1,
SIMPLE BEAM - SAFETY FACTOR 1.5**

Cope Sys. No.	6 Ft. Span			8 Ft. Span			10 Ft. Span			12 Ft. Span			16 Ft. Span			20 Ft. Span			24 Ft. Span			25 Ft. Span		
	w	d	k	w	d	k	w	d	k	w	d	k	w	d	k	w	d	k	w	d	k	w	d	k
823P/G/S	230	0.30		126	0.52	0.004	79	0.79	0.010	53	1.11	0.021												
824P/G/S	292	0.23	†	164	0.42	0.003	103	0.63	0.006	69	0.89	0.013												
825P/G/S	383	0.18	†	210	0.31	0.001	127	0.46	0.004	83	0.62	0.007												
826P/G/S	357	0.11	†	194	0.18	†	119	0.28	0.002	79	0.38	0.005												
423P/G/S	358	0.30	†	197	0.53	0.003	124	0.81	0.007	83	1.13	0.014												
8B4P/G/S	360	0.26	†	198	0.46	0.002	124	0.70	0.006	84	0.98	0.012												
825P/G/S	383	0.18	†	210	0.31	0.001	127	0.46	0.004	83	0.62	0.007												
826P/G/S	357	0.11	†	194	0.18	†	119	0.28	0.002	79	0.38	0.005												
6B4P/G/S	453	0.27	†	249	0.47	0.002	156	0.71	0.005	106	1.00	0.009												
6B5P/G/S	591	0.21	†	325	0.36	0.001	203	0.55	0.003	137	0.77	0.006												
626P/G/S	460	0.11	†	250	0.19	†	154	0.29	0.002	103	0.40	0.004												
8D4P/G/S				290	0.53	0.002	182	0.81	0.004	126	1.17	0.009	65	1.91	0.290									
645P/G/S				444	0.42	†	273	0.63	0.002	186	0.89	0.005	100	1.51	0.015									
646P/G/S				574	0.42	†	367	0.55	0.001	245	0.76	0.003	123	1.22	0.010									
6D4P/G/S				381	0.56	0.001	244	0.88	0.004	169	1.27	0.008	88	2.08	0.024									
645P/G/S				444	0.42	†	273	0.63	0.002	186	0.89	0.005	100	1.51	0.015									
646P/G/S				574	0.42	†	367	0.55	0.001	245	0.76	0.003	123	1.22	0.010									
4D4P/G/S				487	0.58	0.001	312	0.91	0.003	216	1.31	0.006	113	2.16	0.019									
645P/G/S				444	0.42	†	273	0.63	0.002	186	0.89	0.005	100	1.51	0.015									
646P/G/S				574	0.42	†	367	0.55	0.001	245	0.76	0.003	123	1.22	0.010									
6D4P/G/S										169	1.27	0.008	88	2.08	0.024	52	2.98	0.057						
645P/G/S										186	0.89	0.005	100	1.51	0.015	53	1.94	0.037						
646P/G/S										245	0.76	0.003	123	1.22	0.010	66	1.59	0.024						
2D4P/G/S										304	1.36	0.004	159	2.24	0.014	94	3.23	0.034						
4D5P/G/S										280	1.02	0.004	145	1.67	0.012	85	2.40	0.028						
6D6P/G/S										269	0.80	0.003	139	1.28	0.009	81	1.82	0.022						
2D5P/G/S										395	1.05	0.003	206	1.74	0.008	121	2.50	0.021						
4D6P/G/S										296	0.79	0.003	152	1.28	0.008	105	1.91	0.018						
2D6P/G/S										300	0.85	0.002	221	1.40	0.006	149	2.00	0.013	79	1.91	0.024	73	2.38	0.033
11D6P/G/S										434	0.66	†	244	1.17	0.005	156	1.82	0.012	108	2.62	0.024	100	2.85	0.029

Note: To convert 1.5 safety factor to 2.0 multiply w, d, k by .75
W=Pounds per linear foot
Metric: for kg/m multiply w by 1.48
d=Deflection (inches)
k= Deflection (in.) for each pound of load
†= Denotes k is less than .001 inch

HAT CABLE TRAY SYSTEM

OVERVIEW

COPE HAT is a prefabricated metal structure consisting of reinforced hat-shaped rungs, arc-welded to the side rails, and is manufactured to NEMA Standard VE-1. Cope Hat rungs are fastened to the side rails with an automatic, self-indexing MIG-arc-welding system, plug welding a $\frac{1}{2}$ " diameter zone. The superior strength of the Cope plug weld withstands the rigors of shipping, handling, erection and cable support service.

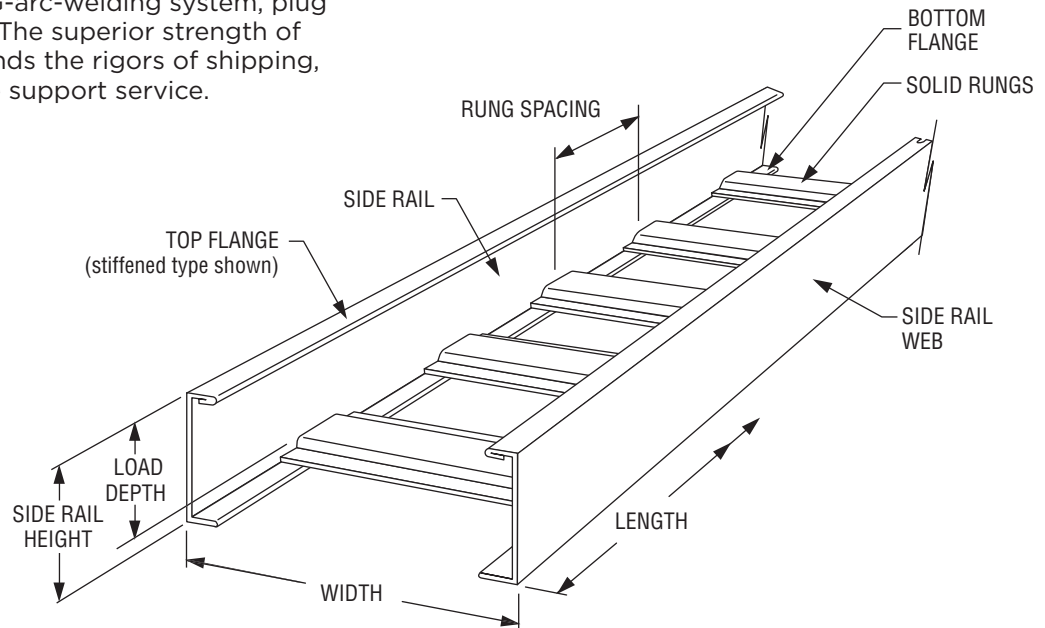

Side Members - Cope Hat side members are designed with top and bottom flanges turned inward. This minimizes the space requirements of the cable tray system, and allows a very low side rail height for each NEMA Standard VE-1 load depth.

Rungs - Cope Hat provides for hat shaped rungs.

Solid Rungs — Solid Hat shaped Rungs are standard on all tray widths.

Solid Hat Rungs for Steel trays are Hat shaped, $2\frac{1}{4}$ " wide and provide for a $\frac{7}{8}$ " cable bearing surface.

Solid Hat Rungs for Aluminum trays are Hat shaped, $3\frac{1}{4}$ " wide and provide for a $1\frac{1}{2}$ " cable bearing surface.

Slotted Rungs — are offered as a special order. Please contact Cope for more information

Rung Spacing - Cope manufactures straight lengths with four standard rung spacings; 6", 9", 12", and 18". The 6" rung spacing results in a $3\frac{3}{4}$ " opening between rungs allowing the tray to be classified as a ventilated tray per NEMA Standard VE-1.

Length - The longitudinal dimensions of standard Cope Hat cable tray are 10', 12', 20', and 24'.

Width - The transverse dimensions of Cope Hat cable tray are measured inside, (from side member web to side member web), and are furnished in seven standard widths: 6", 9", 12", 18", 24", 30" and 36".

Overall Width - Overall tray width is equal to the inside or nominal width plus the thickness of the two side rail webs.

$$\text{Overall Tray Width} = \text{Nominal} + \frac{3}{16}" \text{ Width}$$

Load Depth - Measured from the top surface of the rungs to the top of the side member. Cope manufactures four loading depths; $2\frac{7}{8}$ ", $3\frac{5}{8}$ ", $4\frac{5}{8}$ ", and $5\frac{5}{8}$ " corresponding to the four nominal loading depths in NEMA Standard VE-1; 3", 4", 5" and 6".

Overall Height - Cope Hat cable tray overall height is equal to the loading depth plus $\frac{5}{8}$ ".

Fittings - For changing direction both horizontally and vertically, Cope manufactures elbows, tees, and crosses in all widths and loading depths. Fittings are available in three standard radii; 12", 24", and 36". Standard fittings maintain a nominal 9" rung spacing through the centerline of the fitting. Cope manufactures all standard fittings with zero tangents.

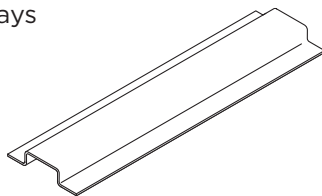

OVERVIEW

COPE HAT CABLE TRAY WITH Four IMPORTANT INDUSTRY-LEADING FEATURES:

1. Compact Economical System -

Cope Hat cable tray is an extremely compact economical flange in cable tray system which allows the designer to utilize this cable tray in tight locations. The extremely low profile Hat Rungs ($\frac{5}{8}$ " high) minimize the required side rail height while maintaining NEMA Standard VE-1 nominal load depths. Overall system height is only $\frac{5}{8}$ " greater than the actual loading depth.

2. Universal Curvilinear Splice Plate System -

The splice plates for rigid connections have a slight curve so they can be used on straight sections or fittings. Tightening of the fastener pulls the plate flush with the side rail. The fasteners are snug and the joint is superior structurally and electrically. Even when hand-tightened, there is pressure on the fastener to hold it securely.

Note: Heavy Duty, Mid Span Splice Plates available upon request.

3. Zero Tangent Fittings -

Tangent as referred to on cable tray fittings is the straight at the end of the curve to accommodate a flat splice plate. This wastes space in tightly packed areas, such as spreader rooms, where the heat of thousands of cables accumulate. Eliminating tangents allow more tray runs to distribute the heat.

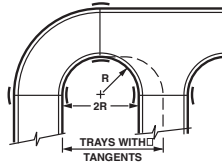

COPE ZERO TANGENT FITTINGS CAN SAVE UP TO 12" PER ROW OF TRAY.

BONUS: Inspection for proper installation of splice plate is visual. If the plate is bowed away from the rail, nuts must be tightened.

4. The Exclusive Auto MIG-Arc-Welded Assembly System -

Cope Hat rungs on straight sections are assembled to the side rails using an automatic, self indexing MIGArc- welding system fusing a $\frac{1}{2}$ " diameter zone. These welds are 700% larger and stronger than the common resistance (spot) weld in use today. Electrical properties of the assembly are unequalled; are well within the NEMA requirements due to the continuous electrical path. The mechanical strength of this welded assembly withstands the rigors of shipping, handling, installation, and service. The size of the weld keeps the vertical axis of the side rail from sloping inward under load. The weld maintains the 90° angle between the side rail and bottom. This allows full use of the section properties. Spot welds do not permit this. Also, stresses on spot welds (barely $\frac{1}{8}$ " in diameter) are so severe that breakage often occurs during shipping and installation. Cope Hat fittings are also assembled by MIG-arc welding.

See page 74
for Grounding
Chart Reference

HAT CABLE TRAY SYSTEM

PART NUMBERING SYSTEM:

STRAIGHT LENGTH

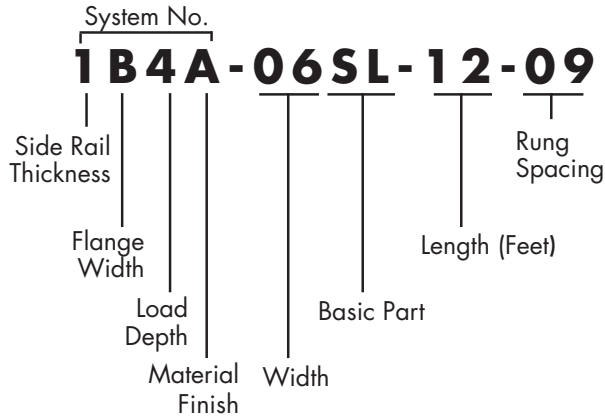

SYSTEM NUMBER (STRAIGHT SECTION ONLY)

The first four digits make up the system number which identifies the structural, dimensional, and material characteristics of the straight length. It is made up of the side rail digits indicating the side rail thickness and flange width, the load depth (inside, in inches) and material finish (galvanized, aluminum or coated).

PREFIX NUMBER (FITTINGS ONLY) - Fittings are ordered using the 3-digit prefix number given in the charts on the fitting pages. Fittings do not have stiffened upper flanges.

Thickness Steel (Ga.)	Flange Width	Load Depth	Material Finish
8 - 18 ga.	2 - 1 ⁹ / ₁₆ " (21mm)	3" (76mm)	P - Mill-Galv.
6 - 16 ga.	4 - 1 ¹ / ₄ " (32mm)	4" (102mm)	G - HDGAF
4 - 14 ga.	7 - 2" (51mm)	5" (127mm)	A - Aluminum
2 - 12 ga.	6" (152mm)	S - 304SS	
11 - 11 ga.			
Thickness Alum (in.)			
1 - Thinner	B - 1 ⁹ / ₁₆ " (21mm)		
3 -	D - 1 ¹ / ₄ " (32mm)		
5 -**	G - 2" (51mm)		
7 -			
9 - Thicker			

**Alum. extruded side rails are individually engineered to loads and spans.

Slotted Rungs provided on trays 6", 9", 12", 18" and 24" wide

Solid Rungs provided on trays 30" and 36" wide.

FITTINGS

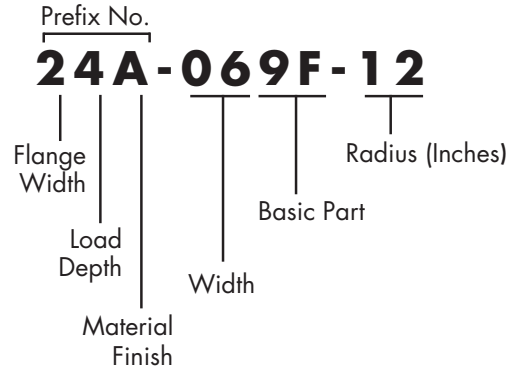

WIDTH - Identifies the inside width of the tray in inches.

BASIC PART NUMBER - Identifies the straight length, fitting, or accessory.

SECONDARY DIMENSION NUMBER - Identifies the length of a straight section in feet, the radius of a fitting in inches, or the second width of a reducer in inches.

RUNG SPACING - Identifies the center-to-center distance between rungs on straight length. Nominal 9" (229mm) rung spacing maintained through centerline of all fittings.

Description	Width (in.)	Basic Part Number	Length	Rung Spacing
-06=6"	(152mm)	SL (Straight Len.)	- 12' (3.7m)	06=6" (152mm)
-09=9"	(229mm)	9F (90° Horiz. El.)	- 24' (7.3m)	09=9" (229mm)
-12=12"	(305mm)	6F (60° Horiz. El.)	- 10' (3m)	12=12" (305mm)
-18=18"	(457mm)	4F (45° Horiz. El.)	- 20' (6m)	18=18" (457mm)
-24=24"	(610mm)	3F (30° Horiz. El.)		
-30=30"	(762mm)	90 (90° Out. Vert. El.)		
-36=36"	(914mm)	60 (60° Out. Vert. El.)		
		40 (45° Out. Vert. El.)		
		30 (30° Out. Vert. El.)		
		9I (90° In. Vert. El.)		
		6I (60° In. Vert. El.)		
		4I (45° In. Vert. El.)		
		3I (30° In. Vert. El.)		
		FT (Horiz. Tee)		
		FC (Horiz. Cross)		
		VT (Vert. Tee)		
		SR (Vert. Cable Support Elbow)		
		ST (Straight Reducer)		
		RH (Right Hand Reducer)		
		LH (Left Hand Reducer)		
		AF (Adjustable Elbow)		
		RY & LY (45° "Y" Branch)		
				Radius (in.)
				-12=12" (205mm)
				-24=24" (610mm)
				-36=36" (914mm)

STRAIGHT LENGTH [SL]

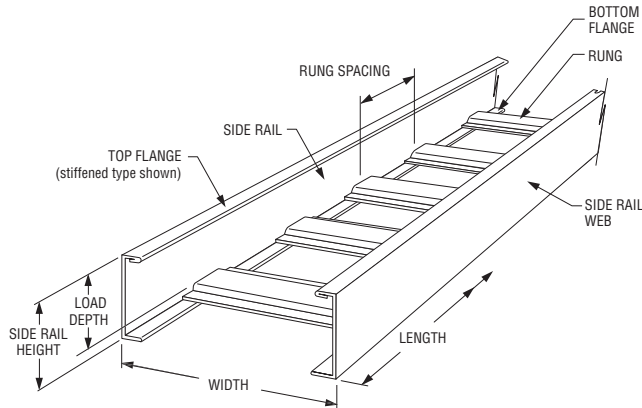

Cope Hat cable tray is manufactured in 10', 12', 20' and 24' lengths; 6", 9", 12", 18", 24", 30" and 36" widths and 3", 4", 5", and 6" nominal load depths. Sufficient connectors are supplied to assemble straight sections and fittings for each other. Connectors for field cuts must be ordered separately.

CATALOG NUMBER

SYSTEM	BASIC WIDTH	BASIC NO.	LENGTH (FT.)	RUNG SPACING
See Pages 102 – 105	-06	SL	-10	-04
	-09		-12	-06
	-12		-20	-09
	-18		-24	-12
	-24			-18
	-30			
	-36			

Example: 1B4A-06SL-12-09 is a 4" load depth aluminum Hat with a 1⁹/₁₆" flange, 6" wide, 12' long, with 9" rung spacing.

CONVERSION TABLE

English	6"	9"	12"	18"	24"	30"	36"	12'	24'	10'	20'
Metric (mm)	152	229	305	457	610	762	914	3.7m	7.3m	3m	6m

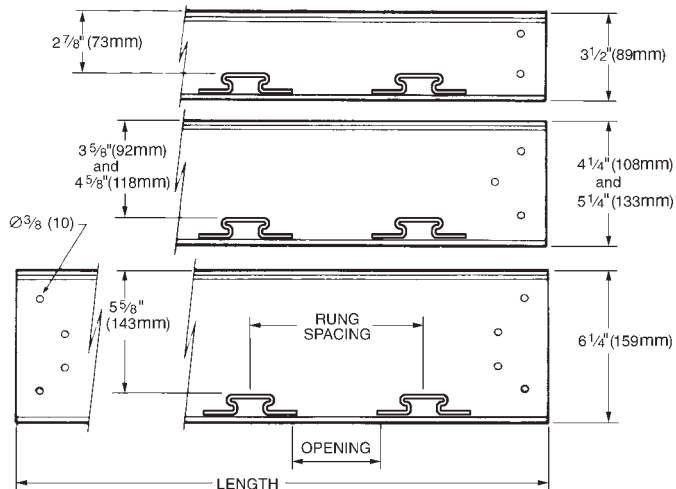
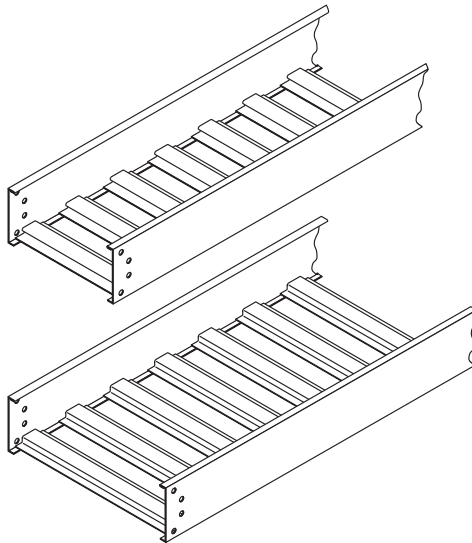

MATERIAL & FINISH SPECIFICATIONS (HAT CABLE TRAY)

	Pre-Galvanized Steel	Hot-Dip Galvanized after Fabrication ASTM A-123	Aluminum	Type 304 Stainless Steel
Siderails	ASTM A-653-G90 CS (18 & 16 Gage) ASTM A-653-G90 CS (14 & 12 Gage)	ASTM A-1008 (18 & 16 Gage) ASTM A-1011 (14 & 12 Gage)	AA-6063-T6 Extruded	ASTM A-240; Type 304
Rungs	ASTM A-653-G90 CS	ASTM A-1008	AA-6063-H34	ASTM A-269; Type 304
Splice Plate Finish	ASTM A-1011 ASTM A-591 Class C	ASTM A-1011 ASTM A-123 Grade 65	AA-5052-H34	ASTM A-240; Type 304 2B Finish (Typical)
Connector Bolts	SAE J429 Grade 1 (ASTM A-307 Grade A)	SAE J429 Grade 1 (ASTM A-307 Grade A)	SAE J429 Grade 1 (ASTM A-307 Grade A)	AISI Type 304 Stainless Steel
Bolt Plating	ASTM B-633.0002" Zinc	ASTM B-633.0002" Zinc	ASTM B-633.0002" Zinc	
Covers	ASTM A-653-G90 CQ	ASTM A-653-G90 CQ	AA-3003 H14 or 3150 H14	ASTM A-240; Type 304

HAT CABLE TRAY SYSTEM

90° HORIZONTAL ELBOW [9F]

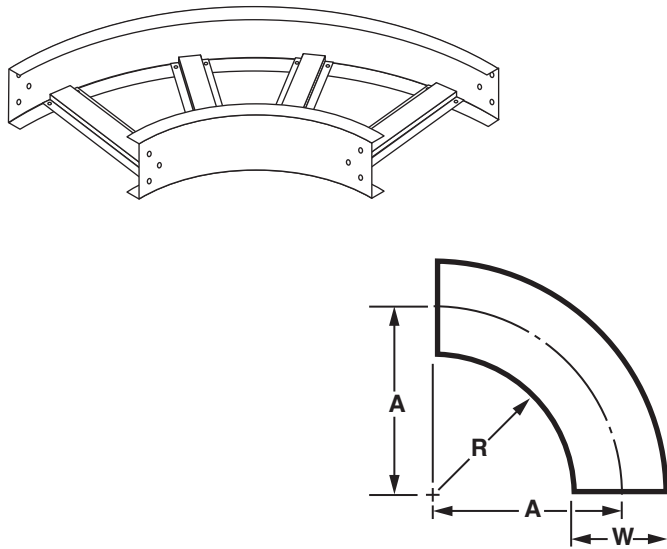

60° HORIZONTAL ELBOW [6F]

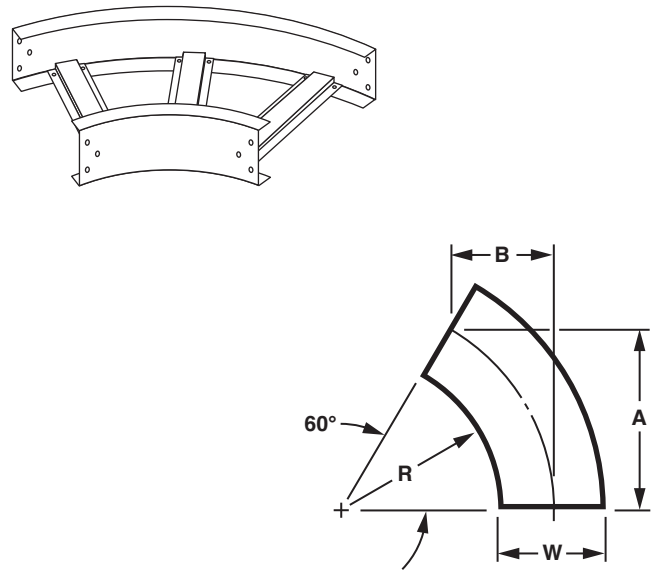

CSA CERTIFIED FOR CSA SYSTEMS

Radius - R	Width - W	"A" Dimension	Part Number
12" (305mm)	6" (152mm)	15" (381mm)	XXX-069F-12
	9" (229mm)	16½" (419mm)	XXX-099F-12
	12" (305mm)	18" (457mm)	XXX-129F-12
	18" (457mm)	21" (533mm)	XXX-189F-12
	24" (610mm)	24" (610mm)	XXX-249F-12
	30" (762mm)	27" (686mm)	XXX-309F-12
	36" (914mm)	30" (762mm)	XXX-369F-12
24" (610mm)	6" (152mm)	27" (686mm)	XXX-069F-24
	9" (229mm)	28½" (724mm)	XXX-099F-24
	12" (305mm)	30" (762mm)	XXX-129F-24
	18" (457mm)	33" (838mm)	XXX-189F-24
	24" (610mm)	36" (914mm)	XXX-249F-24
	30" (762mm)	39" (991mm)	XXX-309F-24
	36" (914mm)	42" (1067mm)	XXX-369F-24
36" (914mm)	6" (152mm)	39" (991mm)	XXX-069F-36
	9" (229mm)	40½" (1029mm)	XXX-099F-36
	12" (305mm)	42" (1067mm)	XXX-129F-36
	18" (457mm)	45" (1143mm)	XXX-189F-36
	24" (610mm)	48" (1219mm)	XXX-249F-36
	30" (762mm)	51" (1295mm)	XXX-309F-36
	36" (914mm)	54" (1372mm)	XXX-369F-36

Example: 24A-129F-12

CSA CERTIFIED FOR CSA SYSTEMS

Radius - R	Width - W	"A" Dimension	"B" Dimension	Part Number
12" (305mm)	6" (152mm)	13" (330mm)	7½" (191mm)	XXX-066F-12
	9" (229mm)	14¼" (362mm)	8¼" (210mm)	XXX-096F-12
	12" (305mm)	15⅝" (397mm)	9" (229mm)	XXX-126F-12
	18" (457mm)	18¼" (464mm)	10½" (267mm)	XXX-186F-12
	24" (610mm)	20¾" (527mm)	12" (305mm)	XXX-246F-12
	30" (762mm)	23⅜" (594mm)	13½" (343mm)	XXX-306F-12
	36" (914mm)	26" (660mm)	15" (381mm)	XXX-366F-12
24" (610mm)	6" (152mm)	23⅜" (594mm)	13½" (343mm)	XXX-066F-24
	9" (229mm)	24¾" (629mm)	14¼" (362mm)	XXX-096F-24
	12" (305mm)	26" (660mm)	15" (381mm)	XXX-126F-24
	18" (457mm)	28⅝" (727mm)	16½" (416mm)	XXX-186F-24
	24" (610mm)	31¼" (794mm)	18" (457mm)	XXX-246F-24
	30" (762mm)	33¾" (857mm)	19½" (495mm)	XXX-306F-24
	36" (914mm)	36⅝" (924mm)	21" (533mm)	XXX-366F-24
36" (914mm)	6" (152mm)	33¾" (857mm)	19½" (495mm)	XXX-066F-36
	9" (229mm)	35⅝" (892mm)	20¼" (514mm)	XXX-096F-36
	12" (305mm)	36⅝" (924mm)	21" (533mm)	XXX-126F-36
	18" (457mm)	39" (991mm)	22½" (572mm)	XXX-186F-36
	24" (610mm)	41⅝" (1057mm)	24" (610mm)	XXX-246F-36
	30" (762mm)	44⅝" (1121mm)	25½" (648mm)	XXX-306F-36
	36" (914mm)	46¾" (1187mm)	27" (686mm)	XXX-366F-36

Example: 24A-126F-12

See page 74
for Grounding
Chart Reference

45° HORIZONTAL ELBOW [4F]

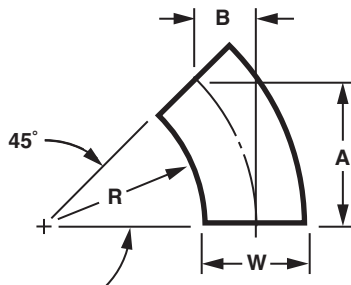
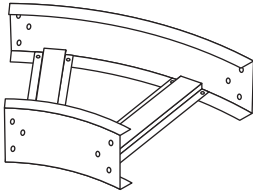

30° HORIZONTAL ELBOW [3F]

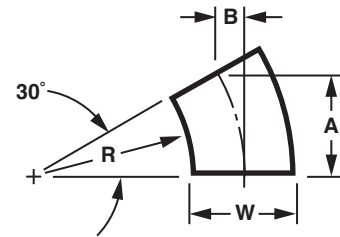
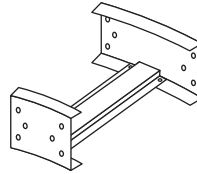

CSA CERTIFIED FOR CSA SYSTEMS

Radius - R	Width - W	"A" Dimension	"B" Dimension	Part Number
12" (305mm)	6" (152mm)	10 ⁵ / ₈ " (270mm)	4 ³ / ₈ " (111mm)	XXX-064F-12
	9" (229mm)	11 ⁵ / ₈ " (295mm)	4 ⁷ / ₈ " (124mm)	XXX-094F-12
	12" (305mm)	12 ³ / ₄ " (324mm)	5 ¹ / ₄ " (133mm)	XXX-124F-12
	18" (457mm)	14 ⁷ / ₈ " (378mm)	6 ¹ / ₈ " (156mm)	XXX-184F-12
	24" (610mm)	17" (432mm)	7" (178mm)	XXX-244F-12
	30" (762mm)	19 ⁷ / ₈ " (486mm)	7 ⁷ / ₈ " (200mm)	XXX-304F-12
36" (914mm)	21 ¹ / ₄ " (540mm)	8 ³ / ₄ " (222mm)	XXX-364F-12	
24" (610mm)	6" (152mm)	19 ¹ / ₈ " (486mm)	7 ⁷ / ₈ " (200mm)	XXX-064F-24
	9" (229mm)	20 ¹ / ₈ " (511mm)	8 ³ / ₈ " (213mm)	XXX-094F-24
	12" (305mm)	21 ¹ / ₄ " (540mm)	8 ³ / ₄ " (222mm)	XXX-124F-24
	18" (457mm)	23 ³ / ₈ " (594mm)	9 ⁵ / ₈ " (244mm)	XXX-184F-24
	24" (610mm)	25 ¹ / ₂ " (648mm)	10 ¹ / ₂ " (267mm)	XXX-244F-24
	30" (762mm)	27 ⁵ / ₈ " (702mm)	11 ¹ / ₂ " (292mm)	XXX-304F-24
36" (914mm)	29 ³ / ₄ " (756mm)	12 ³ / ₈ " (314mm)	XXX-364F-24	
36" (914mm)	6" (152mm)	27 ⁵ / ₈ " (702mm)	11 ¹ / ₂ " (292mm)	XXX-064F-36
	9" (229mm)	28 ⁵ / ₈ " (727mm)	11 ⁷ / ₈ " (302mm)	XXX-094F-36
	12" (305mm)	29 ³ / ₄ " (756mm)	12 ³ / ₈ " (314mm)	XXX-124F-36
	18" (457mm)	31 ¹ / ₈ " (810mm)	13 ¹ / ₄ " (337mm)	XXX-184F-36
	24" (610mm)	34" (864mm)	14 ¹ / ₈ " (359mm)	XXX-244F-36
	30" (762mm)	36 ¹ / ₈ " (918mm)	15" (381mm)	XXX-304F-36
36" (914mm)	38 ¹ / ₄ " (972mm)	15 ⁷ / ₈ " (403mm)	XXX-364F-36	

Example: 24A-124F-12

CSA CERTIFIED FOR CSA SYSTEMS

Radius - R	Width - W	"A" Dimension	"B" Dimension	Part Number
12" (305mm)	6" (152mm)	7 ¹ / ₂ " (191mm)	2" (51mm)	XXX-063F-12
	9" (229mm)	8 ¹ / ₄ " (210mm)	2 ¹ / ₄ " (57mm)	XXX-093F-12
	12" (305mm)	9" (229mm)	2 ⁵ / ₈ " (60mm)	XXX-123F-12
	18" (457mm)	10 ¹ / ₂ " (267mm)	2 ⁷ / ₈ " (73mm)	XXX-183F-12
	24" (610mm)	12" (305mm)	3 ¹ / ₄ " (83mm)	XXX-243F-12
	30" (762mm)	13 ¹ / ₂ " (343mm)	3 ⁵ / ₈ " (92mm)	XXX-303F-12
36" (914mm)	15" (381mm)	4" (102mm)	XXX-363F-12	
24" (610mm)	6" (152mm)	13 ¹ / ₂ " (343mm)	3 ⁵ / ₈ " (92mm)	XXX-063F-24
	9" (229mm)	14 ¹ / ₄ " (362mm)	3 ⁷ / ₈ " (98mm)	XXX-093F-24
	12" (305mm)	15" (381mm)	4" (102mm)	XXX-123F-24
	18" (457mm)	16 ¹ / ₂ " (419mm)	4 ³ / ₈ " (111mm)	XXX-183F-24
	24" (610mm)	18" (457mm)	4 ⁷ / ₈ " (124mm)	XXX-243F-24
	30" (762mm)	19 ¹ / ₂ " (495mm)	5 ¹ / ₄ " (133mm)	XXX-303F-24
36" (914mm)	21" (533mm)	5 ⁵ / ₈ " (143mm)	XXX-363F-24	
36" (914mm)	6" (152mm)	19 ¹ / ₂ " (495mm)	5 ¹ / ₄ " (133mm)	XXX-063F-36
	9" (229mm)	20 ¹ / ₄ " (514mm)	5 ¹ / ₂ " (140mm)	XXX-093F-36
	12" (305mm)	21" (533mm)	5 ⁵ / ₈ " (143mm)	XXX-123F-36
	18" (457mm)	22 ¹ / ₂ " (572mm)	6" (152mm)	XXX-183F-36
	24" (610mm)	24" (610mm)	6 ¹ / ₂ " (165mm)	XXX-243F-36
	30" (762mm)	25 ¹ / ₂ " (648mm)	6 ⁷ / ₈ " (175mm)	XXX-303F-36
36" (914mm)	27" (686mm)	7 ¹ / ₄ " (184mm)	XXX-363F-36	

Example: 24A-123F-12

See page 74
for Grounding
Chart Reference

HAT CABLE TRAY SYSTEM

HORIZONTAL TEE [FT]

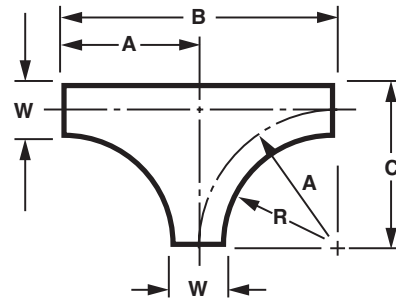
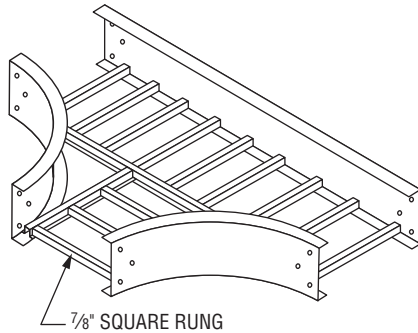

CSA CERTIFIED FOR CSA SYSTEMS

Radius - R	Width - W	"A" Dimension		"B" Dimension		"C" Dimension		Part Number
12" (305mm)	6" (152mm)	15"	(381mm)	30"	(762mm)	18"	(457mm)	XXX-06FT-12
	9" (229mm)	16½"	(419mm)	33"	(838mm)	21"	(533mm)	XXX-09FT-12
	12" (305mm)	18"	(457mm)	36"	(914mm)	24"	(610mm)	XXX-12FT-12
	18" (457mm)	21"	(533mm)	42"	(1067mm)	30"	(762mm)	XXX-18FT-12
	24" (610mm)	24"	(610mm)	48"	(1219mm)	36"	(914mm)	XXX-24FT-12
	30" (762mm)	27"	(686mm)	54"	(1372mm)	42"	(1067mm)	XXX-30FT-12
24" (610mm)	6" (152mm)	27"	(686mm)	54"	(1372mm)	30"	(762mm)	XXX-06FT-24
	9" (229mm)	28½"	(724mm)	57"	(1448mm)	33"	(838mm)	XXX-09FT-24
	12" (305mm)	30"	(762mm)	60"	(1524mm)	36"	(914mm)	XXX-12FT-24
	18" (457mm)	33"	(838mm)	66"	(1676mm)	42"	(1067mm)	XXX-18FT-24
	24" (610mm)	36"	(914mm)	72"	(1829mm)	48"	(1219mm)	XXX-24FT-24
	30" (762mm)	39"	(991mm)	78"	(1981mm)	54"	(1372mm)	XXX-30FT-24
36" (914mm)	6" (152mm)	39"	(991mm)	78"	(1981mm)	42"	(1067mm)	XXX-06FT-36
	9" (229mm)	40½"	(1029mm)	81"	(2057mm)	45"	(1143mm)	XXX-09FT-36
	12" (305mm)	42"	(1067mm)	84"	(2134mm)	48"	(1219mm)	XXX-12FT-36
	18" (457mm)	45"	(1143mm)	90"	(2286mm)	54"	(1372mm)	XXX-18FT-36
	24" (610mm)	48"	(1219mm)	96"	(2438mm)	60"	(1524mm)	XXX-24FT-36
	30" (762mm)	51"	(1295mm)	102"	(2591mm)	66"	(1676mm)	XXX-30FT-36
36" (914mm)	54"	(1372mm)	108"	(2743mm)	72"	(1829mm)	XXX-36FT-36	

Example: 24A-12FT-12

See page 74
for Grounding
Chart Reference

HORIZONTAL CROSS [FC]

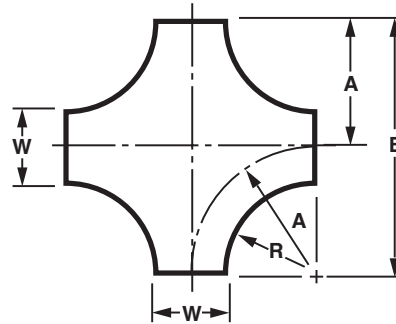
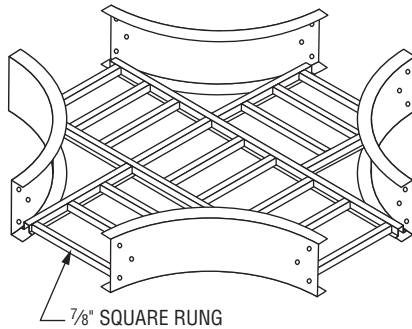

CSA CERTIFIED FOR CSA SYSTEMS

Radius - R	Width - W	"A" Dimension	"B" Dimension	Part Number
12" (305mm)	6" (152mm)	15" (381mm)	30" (762mm)	XXX-06FC-12
	9" (229mm)	16½" (419mm)	33" (838mm)	XXX-09FC-12
	12" (305mm)	18" (457mm)	36" (914mm)	XXX-12FC-12
	18" (457mm)	21" (533mm)	42" (1067mm)	XXX-18FC-12
	24" (610mm)	24" (610mm)	48" (1219mm)	XXX-24FC-12
	30" (762mm)	27" (686mm)	54" (1372mm)	XXX-30FC-12
24" (610mm)	36" (914mm)	30" (762mm)	60" (1524mm)	XXX-36FC-12
	6" (152mm)	27" (686mm)	54" (1372mm)	XXX-06FC-24
	9" (229mm)	28½" (724mm)	57" (1448mm)	XXX-09FC-24
	12" (305mm)	30" (762mm)	60" (1524mm)	XXX-12FC-24
	18" (457mm)	33" (838mm)	66" (1676mm)	XXX-18FC-24
	24" (610mm)	36" (914mm)	72" (1829mm)	XXX-24FC-24
36" (914mm)	30" (762mm)	39" (991mm)	78" (1981mm)	XXX-30FC-24
	36" (914mm)	42" (1067mm)	84" (2134mm)	XXX-36FC-24
	6" (152mm)	39" (991mm)	78" (1981mm)	XXX-06FC-36
	9" (229mm)	40½" (1029mm)	81" (2057mm)	XXX-09FC-36
	12" (305mm)	42" (1067mm)	84" (2134mm)	XXX-12FC-36
	18" (457mm)	45" (1143mm)	90" (2286mm)	XXX-18FC-36
36" (914mm)	24" (610mm)	48" (1219mm)	96" (2438mm)	XXX-24FC-36
	30" (762mm)	51" (1295mm)	102" (2591mm)	XXX-30FC-36
	36" (914mm)	54" (1372mm)	108" (2743mm)	XXX-36FC-36

Example: 24A-12FC-12

See page 74
for Grounding
Chart Reference

HAT CABLE TRAY SYSTEM

HORIZONTAL TAPPED TEE [TT]

CSA CERTIFIED FOR CSA SYSTEMS

R Radius	W Width	W1 Width	"A" Dimension	"C" Dimension	Part Number		
12" (305mm)	36" (914mm)	30" (762mm)	27" (686mm)	48" (1219mm)	XXX-36TT-30-12		
		24" (610mm)	24" (610mm)		XXX-36TT-24-12		
		18" (457mm)	21" (533mm)		XXX-36TT-18-12		
		12" (305mm)	18" (457mm)		XXX-36TT-12-12		
		9" (229mm)	16½" (419mm)		XXX-36TT-09-12		
		6" (152mm)	15" (381mm)		XXX-36TT-06-12		
	30" (762mm)	24" (610mm)	24" (610mm)	42" (1067mm)	XXX-30TT-24-12		
		18" (457mm)	21" (533mm)		XXX-30TT-18-12		
		12" (305mm)	18" (457mm)		XXX-30TT-12-12		
		9" (229mm)	16½" (419mm)		XXX-30TT-09-12		
		6" (152mm)	15" (381mm)		XXX-30TT-06-12		
		24" (610mm)	18" (457mm)		21" (533mm)	36" (914mm)	XXX-24TT-18-12
	12" (305mm)		18" (457mm)	XXX-24TT-12-12			
	9" (229mm)		16½" (419mm)	XXX-24TT-09-12			
	6" (152mm)		15" (381mm)	XXX-24TT-06-12			
	18" (457mm)		12" (305mm)	18" (457mm)	30" (762mm)		XXX-18TT-12-12
			9" (229mm)	16½" (419mm)			XXX-18TT-09-12
		6" (152mm)	15" (381mm)	XXX-18TT-06-12			
12" (305mm)	9" (229mm)	16½" (419mm)	24" (610mm)	XXX-12TT-09-12			
	6" (152mm)	15" (381mm)		XXX-12TT-06-12			
9" (229mm)	6" (152mm)	15" (381mm)	21" (533mm)	XXX-09TT-06-12			
24" (610mm)	36" (914mm)	30" (762mm)	39" (991mm)	60" (1524mm)	XXX-36TT-30-24		
		24" (610mm)	36" (914mm)		XXX-36TT-24-24		
		18" (457mm)	33" (838mm)		XXX-36TT-18-24		
		12" (305mm)	30" (762mm)		XXX-36TT-12-24		
		9" (229mm)	28½" (724mm)		XXX-36TT-09-24		
		6" (152mm)	27" (686mm)		XXX-36TT-06-24		
	30" (762mm)	24" (610mm)	36" (914mm)	54" 1372mm	XXX-30TT-24-24		
		18" (457mm)	33" (838mm)		XXX-30TT-18-24		
		12" (305mm)	30" (762mm)		XXX-30TT-12-24		
		9" (229mm)	28½" (724mm)		XXX-30TT-09-24		
		6" (152mm)	27" (686mm)		XXX-30TT-06-24		
		24" (610mm)	18" (457mm)		33" (838mm)	48" 1219mm	XXX-24TT-18-24
	12" (305mm)		30" (762mm)	XXX-24TT-12-24			
	9" (229mm)		28½" (724mm)	XXX-24TT-09-24			
	6" (152mm)		27" (686mm)	XXX-24TT-06-24			
	18" (457mm)		12" (305mm)	30" (762mm)	42" 1067mm		XXX-18TT-12-24
			9" (229mm)	28½" (724mm)			XXX-18TT-09-24
		6" (152mm)	27" (686mm)	XXX-18TT-06-24			
	12" (305mm)	9" (229mm)	28½" (724mm)	36" 914mm	XXX-12TT-09-24		
		6" (152mm)	27" (686mm)		XXX-12TT-06-24		
	9" (229mm)	6" (152mm)	27" (686mm)	33" 838mm	XXX-09TT-06-24		

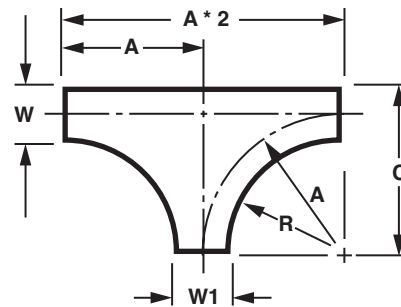
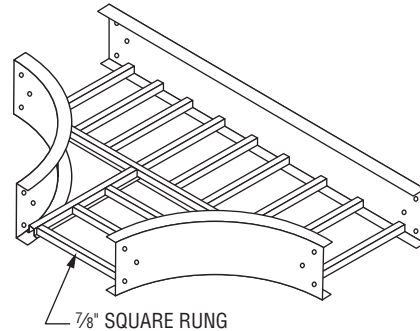

36" (914mm)	30" (762mm)	30" (762mm)	51" (1295mm)	72" (1829mm)	XXX-36TT-30-36		
		24" (610mm)	48" (1219mm)		XXX-36TT-24-36		
		18" (457mm)	45" (1143mm)		XXX-36TT-18-36		
		12" (305mm)	42" (1067mm)		XXX-36TT-12-36		
		9" (229mm)	40½" (1029mm)		XXX-36TT-09-36		
		6" (152mm)	39" (991mm)		XXX-36TT-06-36		
30" (762mm)	24" (610mm)	24" (610mm)	48" (1219mm)	66" (1676mm)	XXX-30TT-24-36		
		18" (457mm)	45" (1143mm)		XXX-30TT-18-36		
		12" (305mm)	42" (1067mm)		XXX-30TT-12-36		
		9" (229mm)	40½" (1029mm)		XXX-30TT-09-36		
		6" (152mm)	39" (991mm)		XXX-30TT-06-36		
		24" (610mm)	18" (457mm)		18" (457mm)	45" (1143mm)	60" (1524mm)
12" (305mm)	42" (1067mm)			XXX-24TT-12-36			
9" (229mm)	40½" (1029mm)			XXX-24TT-09-36			
6" (152mm)	39" (991mm)			XXX-24TT-06-36			
18" (457mm)	12" (305mm)			42" (1067mm)	54" (1372mm)	XXX-18TT-12-36	
	9" (229mm)			40½" (1029mm)		XXX-18TT-09-36	
	6" (152mm)	39" (991mm)	XXX-18TT-06-36				
12" (305mm)	9" (229mm)	40½" (1029mm)	48" (1219mm)	XXX-12TT-09-36			
	6" (152mm)	39" (991mm)		XXX-12TT-06-36			
9" (229mm)	6" (152mm)	39" (991mm)	45" (1143mm)	XXX-09TT-06-36			

See page 74
for Grounding
Chart Reference

HORIZONTAL TAPPED CROSS [TC] [PAGE 1 OF 2]

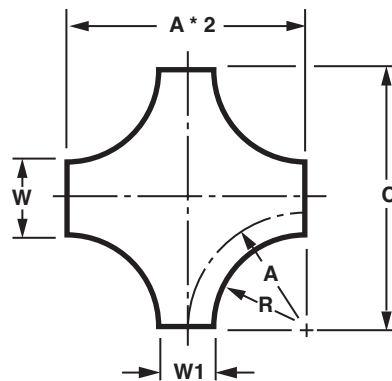
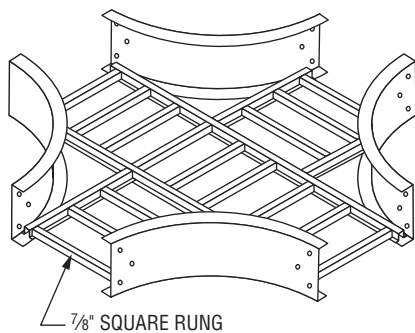

CSA CERTIFIED FOR CSA SYSTEMS

R Radius	W Width	W1 Width	"A" Dimension	"C" Dimension	Part Number
12" (305mm)	36" (914mm)	30" (762mm)	27" (686mm)	60" 1524mm	XXX-36TC-30-12
		24" (610mm)	24" (610mm)		XXX-36TC-24-12
		18" (457mm)	21" (533mm)		XXX-36TC-18-12
		12" (305mm)	18" (457mm)		XXX-36TC-12-12
		9" (229mm)	16½" (419mm)		XXX-36TC-09-12
		6" (152mm)	15" (381mm)		XXX-36TC-06-12
	30" (762mm)	24" (610mm)	24" (610mm)	54" 1372mm	XXX-30TC-24-12
		18" (457mm)	21" (533mm)		XXX-30TC-18-12
		12" (305mm)	18" (457mm)		XXX-30TC-12-12
		9" (229mm)	16½" (419mm)		XXX-30TC-09-12
		6" (152mm)	15" (381mm)		XXX-30TC-06-12
	24" (610mm)	18" (457mm)	21" (533mm)	48" 1219mm	XXX-24TC-18-12
		12" (305mm)	18" (457mm)		XXX-24TC-12-12
		9" (229mm)	16½" (419mm)		XXX-24TC-09-12
		6" (152mm)	15" (381mm)		XXX-24TC-06-12
	18" (457mm)	12" (305mm)	18" (457mm)	42" 1067mm	XXX-18TC-12-12
		9" (229mm)	16½" (419mm)		XXX-18TC-09-12
		6" (152mm)	15" (381mm)		XXX-18TC-06-12
	12" (305mm)	9" (229mm)	16½" (419mm)	36" 914mm	XXX-12TC-09-12
		6" (152mm)	15" (381mm)		XXX-12TC-06-12
	9" (229mm)	6" (152mm)	15" (381mm)	33" 838mm	XXX-09TC-06-12

See page 74
for Grounding
Chart Reference

HAT CABLE TRAY SYSTEM

HORIZONTAL TAPPED CROSS [TC] [PAGE 2 OF 2]

CSA CERTIFIED FOR CSA SYSTEMS

R Radius	W Width	W1 Width	"A" Dimension	"C" Dimension	Part Number
24" (610mm)	36" (914mm)	30" (762mm)	39" (991mm)	84" 2134mm	XXX-36TC-30-24
		24" (610mm)	36" (914mm)		XXX-36TC-24-24
		18" (457mm)	33" (838mm)		XXX-36TC-18-24
		12" (305mm)	30" (762mm)		XXX-36TC-12-24
		9" (229mm)	28½" (724mm)		XXX-36TC-09-24
		6" (152mm)	27" (686mm)		XXX-36TC-06-24
	30" (762mm)	24" (610mm)	36" (914mm)	78" 1981mm	XXX-30TC-24-24
		18" (457mm)	33" (838mm)		XXX-30TC-18-24
		12" (305mm)	30" (762mm)		XXX-30TC-12-24
		9" (229mm)	28½" (724mm)		XXX-30TC-09-24
		6" (152mm)	27" (686mm)		XXX-30TC-06-24
	24" (610mm)	18" (457mm)	33" (838mm)	72" 1829mm	XXX-24TC-18-24
		12" (305mm)	30" (762mm)		XXX-24TC-12-24
		9" (229mm)	28½" (724mm)		XXX-24TC-09-24
		6" (152mm)	27" (686mm)		XXX-24TC-06-24
	18" (457mm)	12" (305mm)	30" (762mm)	66" 1676mm	XXX-18TC-12-24
		9" (229mm)	28½" (724mm)		XXX-18TC-09-24
		6" (152mm)	27" (686mm)		XXX-18TC-06-24
	12" (305mm)	9" (229mm)	28½" (724mm)	60" 1524mm	XXX-12TC-09-24
		6" (152mm)	27" (686mm)		XXX-12TC-06-24
	9" (229mm)	6" (152mm)	27" (686mm)	57" 1448mm	XXX-09TC-06-24
36" (914mm)	36" (914mm)	30" (762mm)	51" (1295mm)	108" 2743mm	XXX-36TC-30-36
		24" (610mm)	48" (1219mm)		XXX-36TC-24-36
		18" (457mm)	45" (1143mm)		XXX-36TC-18-36
		12" (305mm)	42" (1067mm)		XXX-36TC-12-36
		9" (229mm)	40½" (1029mm)		XXX-36TC-09-36
		6" (152mm)	39" (991mm)		XXX-36TC-06-36
	30" (762mm)	24" (610mm)	48" (1219mm)	102" 2591mm	XXX-30TC-24-36
		18" (457mm)	45" (1143mm)		XXX-30TC-18-36
		12" (305mm)	42" (1067mm)		XXX-30TC-12-36
		9" (229mm)	40½" (1029mm)		XXX-30TC-09-36
		6" (152mm)	39" (991mm)		XXX-30TC-06-36
	24" (610mm)	18" (457mm)	45" (1143mm)	96" 2438mm	XXX-24TC-18-36
		12" (305mm)	42" (1067mm)		XXX-24TC-12-36
		9" (229mm)	40½" (1029mm)		XXX-24TC-09-36
		6" (152mm)	39" (991mm)		XXX-24TC-06-36
	18" (457mm)	12" (305mm)	42" (1067mm)	90" 2286mm	XXX-18TC-12-36
		9" (229mm)	40½" (1029mm)		XXX-18TC-09-36
		6" (152mm)	39" (991mm)		XXX-18TC-06-36
	12" (305mm)	9" (229mm)	40½" (1029mm)	84" 2134mm	XXX-12TC-09-36
		6" (152mm)	39" (991mm)		XXX-12TC-06-36
	9" (229mm)	6" (152mm)	39" (991mm)	81" 2057mm	XXX-09TC-06-36

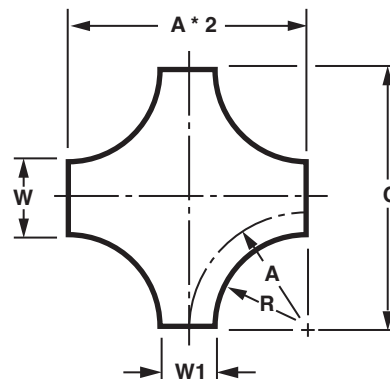

See page 74
for Grounding
Chart Reference

STRAIGHT REDUCER [ST]

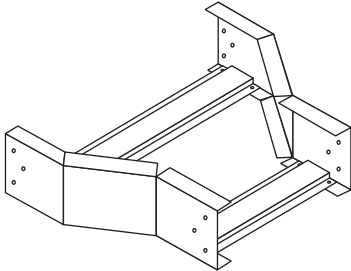

LEFT HAND [LH] & RIGHT HAND [RH] REDUCER

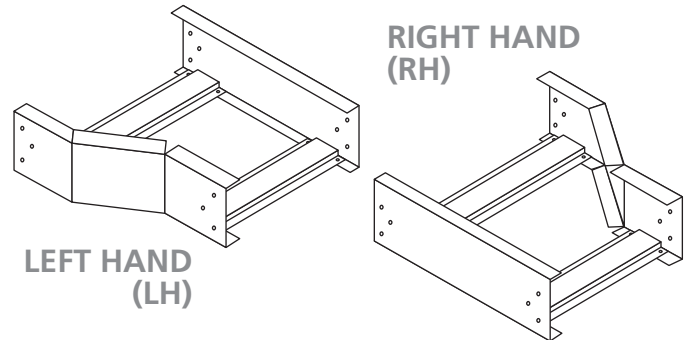

CSA CERTIFIED FOR CSA SYSTEMS

Width - W	Width - W1	"A" Dimension	Part Number
36" (914mm)	30" (762mm)	3" (76mm)	XXX-36ST-30
	24" (610mm)	6" (152mm)	XXX-36ST-24
	18" (457mm)	9" (229mm)	XXX-36ST-18
	12" (305mm)	12" (305mm)	XXX-36ST-12
	9" (229mm)	13½" (343mm)	XXX-36ST-09
	6" (152mm)	15" (381mm)	XXX-36ST-06
30" (762mm)	24" (610mm)	3" (76mm)	XXX-30ST-24
	18" (457mm)	6" (152mm)	XXX-30ST-18
	12" (305mm)	9" (229mm)	XXX-30ST-12
	9" (229mm)	10½" (267mm)	XXX-30ST-09
	6" (152mm)	12" (304mm)	XXX-30ST-06
24" (610mm)	18" (457mm)	3" (76mm)	XXX-24ST-18
	12" (305mm)	6" (152mm)	XXX-24ST-12
	9" (229mm)	7½" (191mm)	XXX-24ST-09
	6" (152mm)	9" (229mm)	XXX-24ST-06
18" (457mm)	12" (305mm)	3" (76mm)	XXX-18ST-12
	9" (229mm)	4½" (114mm)	XXX-18ST-09
	6" (152mm)	6" (152mm)	XXX-18ST-06
12" (305mm)	9" (229mm)	1½" (38mm)	XXX-12ST-09
	6" (152mm)	3" (76mm)	XXX-12ST-06
9" (229mm)	6" (152mm)	1½" (38mm)	XXX-09ST-06

Example: 24A-12ST-06

CSA CERTIFIED FOR CSA SYSTEMS

Width - W	"W1" Dim.	"A" Dim.	"B" Dim.	Part Number
36" (914mm)	30" (914mm)	6" (152mm)	15" (381mm)	XXX-36(LH/RH)-30
	24" (610mm)	12" (305mm)	12" (305mm)	XXX-36(LH/RH)-24
	18" (457mm)	18" (457mm)	9" (229mm)	XXX-36(LH/RH)-18
	12" (305mm)	24" (610mm)	6" (152mm)	XXX-36(LH/RH)-12
	9" (229mm)	27" (686mm)	4½" (114mm)	XXX-36(LH/RH)-09
	6" (152mm)	30" (762mm)	3" (76mm)	XXX-36(LH/RH)-06
30" (762mm)	24" (610mm)	6" (152mm)	12" (305mm)	XXX-30(LH/RH)-24
	18" (457mm)	12" (305mm)	9" (229mm)	XXX-30(LH/RH)-18
	12" (305mm)	18" (457mm)	6" (152mm)	XXX-30(LH/RH)-12
	9" (229mm)	21" (533mm)	4½" (114mm)	XXX-30(LH/RH)-09
	6" (152mm)	24" (610mm)	3" (76mm)	XXX-30(LH/RH)-06
24" (610mm)	18" (457mm)	6" (152mm)	9" (229mm)	XXX-24(LH/RH)-18
	12" (305mm)	12" (305mm)	6" (152mm)	XXX-24(LH/RH)-12
	9" (229mm)	15" (381mm)	4½" (114mm)	XXX-24(LH/RH)-09
	6" (152mm)	18" (457mm)	3" (76mm)	XXX-24(LH/RH)-06
18" (457mm)	12" (305mm)	6" (152mm)	6" (152mm)	XXX-18(LH/RH)-12
	9" (229mm)	9" (229mm)	4½" (114mm)	XXX-18(LH/RH)-09
	6" (152mm)	12" (305mm)	3" (76mm)	XXX-18(LH/RH)-06
12" (305mm)	9" (229mm)	3" (76mm)	4½" (114mm)	XXX-12(LH/RH)-09
	6" (152mm)	6" (152mm)	3" (76mm)	XXX-12(LH/RH)-06
9" (229mm)	6" (152mm)	3" (76mm)	3" (76mm)	XXX-09(LH/RH)-06

Example: 238-12LH-06

See page 74
for Grounding
Chart Reference

HAT CABLE TRAY SYSTEM

ADJUSTABLE ELBOW [AF]

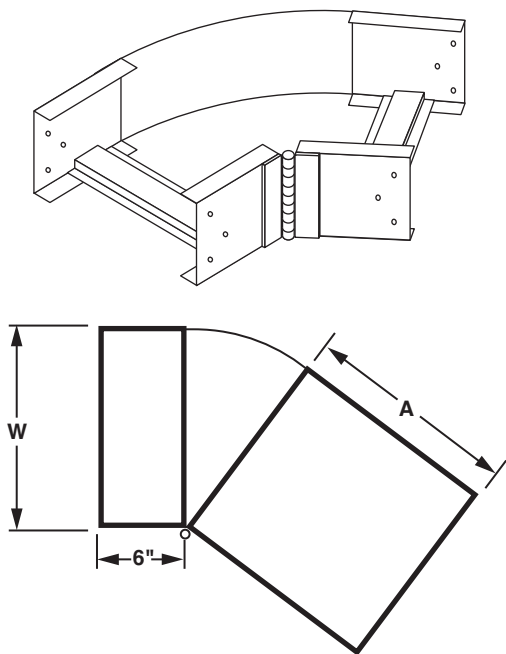

Width - W		"A" Dim.		Part Number
6"	(152mm)	8"	(203mm)	XXX-06AF
9"	(229mm)	11"	(279mm)	XXX-09AF
12"	(305mm)	14"	(356mm)	XXX-12AF
18"	(457mm)	20"	(508mm)	XXX-18AF
24"	(610mm)	26"	(660mm)	XXX-24AF
30"	(762mm)	32"	(813mm)	XXX-30AF
36"	(914mm)	38"	(965mm)	XXX-36AF

Both rails at hinge break to be bonded if fitting is used as equipment grounding conductor.

Example: 24A-12AF

45° "Y" BRANCH LEFT [LY] & RIGHT [RY]

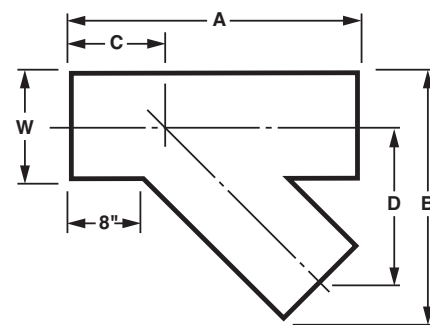
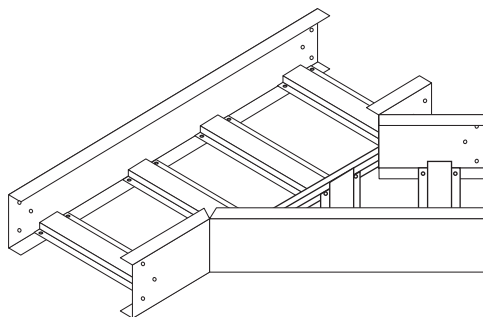

RIGHT SIDE [RY]
SHOWN

CSA CERTIFIED FOR CSA SYSTEMS

Width - W		"A" Dim.		"B" Dim.		"C" Dim.		"D" Dim.		Part Number
6"	(152mm)	22½"	(571mm)	16¼"	(413mm)	9¼"	(289mm)	11⅝"	(283mm)	XXX-06(LY/R)
9"	(229mm)	26¾"	(679mm)	21⅝"	(543mm)	9⅜"	(330mm)	13¾"	(349mm)	XXX-09(LY/R)
12"	(305mm)	31"	(787mm)	26½"	(673mm)	10½"	(375mm)	16¼"	(412mm)	XXX-12(LY/R)
18"	(457mm)	39½"	(1003mm)	36¾"	(933mm)	11¾"	(460mm)	21⅜"	(543mm)	XXX-18(LY/R)
24"	(610mm)	48"	(1219mm)	47"	(1193mm)	13"	(546mm)	26½"	(673mm)	XXX-24(LY/R)
30"	(762mm)	56⅝"	(1432mm)	57¼"	(1454mm)	14⅞"	(629mm)	31⅝"	(803mm)	XXX-30(LY/R)
36"	(914mm)	65"	(1651mm)	67½"	(1714mm)	15½"	(718mm)	36¾"	(933mm)	XXX-36(LY/R)

Example: 24A-12RY

See page 74
for Grounding
Chart Reference

90° VERTICAL ELBOW OUTSIDE [90] & INSIDE [9I]

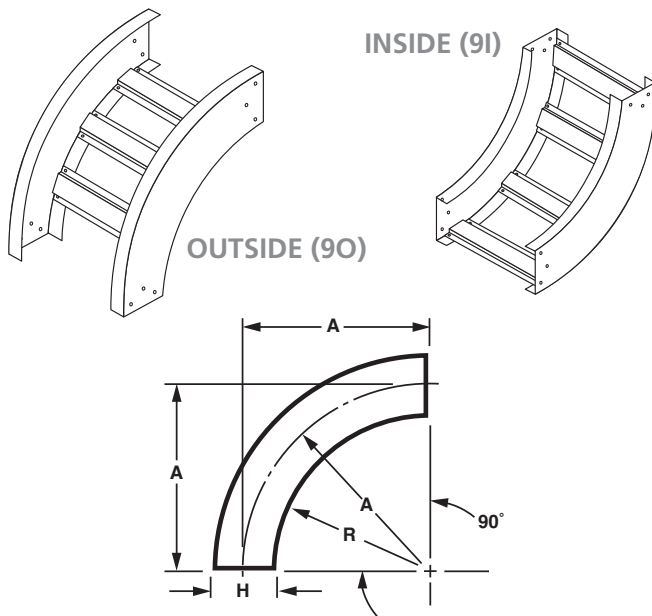

CSA CERTIFIED FOR CSA SYSTEMS

Radius - R	"H" Dim.	"A" Dim.	Part Number
12" (305mm)	3½" (89mm)	13¾" (349mm)	X3X-WW(90/9I)-12
	4¼" (108mm)	14⅞" (359mm)	X4X-WW(90/9I)-12
	5¼" (133mm)	14⅝" (372mm)	X5X-WW(90/9I)-12
	6¼" (159mm)	15⅞" (384mm)	X6X-WW(90/9I)-12
24" (610mm)	3½" (89mm)	25¾" (349mm)	X3X-WW(90/9I)-24
	4¼" (108mm)	26⅞" (664mm)	X4X-WW(90/9I)-24
	5¼" (133mm)	26⅝" (676mm)	X5X-WW(90/9I)-24
	6¼" (159mm)	27⅞" (689mm)	X6X-WW(90/9I)-24
36" (914mm)	7¼" (184mm)	37¾" (702mm)	X3X-WW(90/9I)-36
	4¼" (108mm)	38⅞" (969mm)	X4X-WW(90/9I)-36
	5¼" (133mm)	38⅝" (981mm)	X5X-WW(90/9I)-36
	6¼" (159mm)	39⅞" (994mm)	X6X-WW(90/9I)-36

Example: 24A-129O-12

60° VERTICAL ELBOW OUTSIDE [60] & INSIDE [6I]

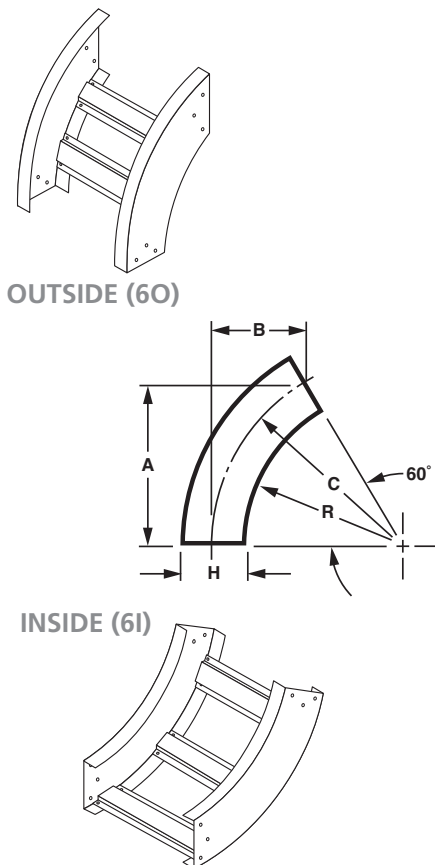

CSA CERTIFIED FOR CSA SYSTEMS

Radius - R	"H" Dim.	"A" Dim.	"B" Dim.	"C" Dim.	Part Number
12" (305mm)	3½" (89mm)	11⅞" (302mm)	6⅞" (175mm)	13¾" (349mm)	X3X-WW(60/6I)-12
	4¼" (108mm)	12¼" (311mm)	7⅞" (181mm)	14⅞" (359mm)	X4X-WW(60/6I)-12
	5¼" (133mm)	12⅝" (321mm)	7⅞" (187mm)	14⅞" (372mm)	X5X-WW(60/6I)-12
	6¼" (159mm)	13⅞" (334mm)	7⅞" (194mm)	15⅞" (384mm)	X6X-WW(60/6I)-12
24" (610mm)	3½" (89mm)	22¼" (565mm)	12⅞" (327mm)	25¾" (654mm)	X3X-WW(60/6I)-24
	4¼" (108mm)	22⅝" (575mm)	13⅞" (334mm)	26⅞" (664mm)	X4X-WW(60/6I)-24
	5¼" (133mm)	23⅞" (588mm)	13⅞" (340mm)	26⅝" (676mm)	X5X-WW(60/6I)-24
	6¼" (159mm)	23½" (597mm)	13" (330mm)	27⅞" (689mm)	X6X-WW(60/6I)-24
36" (914mm)	3½" (89mm)	32¾" (832mm)	18⅞" (480mm)	37¾" (959mm)	X3X-WW(60/6I)-36
	4¼" (108mm)	33" (838mm)	19⅞" (486mm)	38⅞" (969mm)	X4X-WW(60/6I)-36
	5¼" (133mm)	33½" (851mm)	19⅞" (492mm)	38⅝" (981mm)	X5X-WW(60/6I)-36
	6¼" (159mm)	33⅞" (861mm)	19⅞" (499mm)	39⅞" (994mm)	X6X-WW(60/6I)-36

Example: 24A-126O-12

See page 74
for Grounding
Chart Reference

HAT CABLE TRAY SYSTEM

45° VERTICAL ELBOW OUTSIDE [40] & INSIDE [41]

OUTSIDE (40)

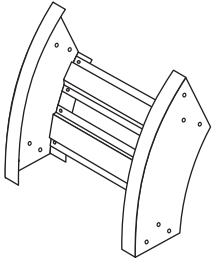

INSIDE (41)

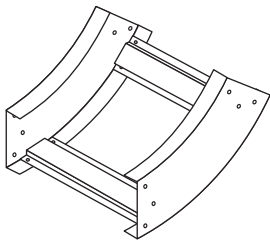

CSA CERTIFIED FOR CSA SYSTEMS

Radius - R	"H" Dim.	"A" Dim.	"B" Dim.	"C" Dim.	Part Number
12" (305mm)	3½" (89mm)	9¾" (248mm)	4" (102mm)	13¾" (349mm)	X3X-WW(40/4)-12
	4¼" (108mm)	10" (254mm)	4⅞" (105mm)	14⅞" (359mm)	X4X-WW(40/4)-12
	5¼" (133mm)	10⅝" (264mm)	4¼" (108mm)	14⅝" (372mm)	X5X-WW(40/4)-12
	6¼" (159mm)	10¾" (273mm)	4½" (114mm)	15⅝" (384mm)	X6X-WW(40/4)-12
24" (610mm)	4¼" (108mm)	18½" (470mm)	7⅞" (194mm)	26⅞" (664mm)	X3X-WW(40/4)-24
	5¼" (133mm)	18⅞" (480mm)	7⅞" (200mm)	26⅞" (676mm)	X4X-WW(40/4)-24
	6¼" (159mm)	19¼" (489mm)	8" (203mm)	27⅞" (689mm)	X5X-WW(40/4)-24
	3½" (89mm)	18¼" (464mm)	7½" (191mm)	25¾" (654mm)	X6X-WW(40/4)-24
36" (914mm)	3½" (89mm)	9¾" (248mm)	4" (102mm)	13¾" (349mm)	X3X-WW(40/4)-36
	4¼" (108mm)	27" (686mm)	11⅞" (283mm)	38⅞" (969mm)	X4X-WW(40/4)-36
	5¼" (133mm)	27⅞" (695mm)	11⅞" (289mm)	38⅞" (981mm)	X5X-WW(40/4)-36
	6¼" (159mm)	27⅞" (702mm)	11½" (292mm)	39⅞" (994mm)	X6X-WW(40/4)-36

Example: 24A-1240-12

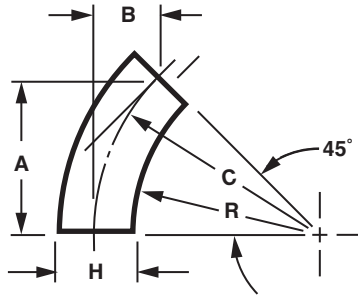

30° VERTICAL ELBOW OUTSIDE [30] & INSIDE [31]

OUTSIDE (30)

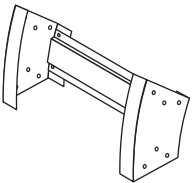

INSIDE (31)

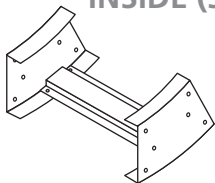

CSA CERTIFIED FOR CSA SYSTEMS

Radius - R	"H" Dim.	"A" Dim.	"B" Dim.	"C" Dim.	Part Number
12" (305mm)	3½" (89mm)	6⅞" (175mm)	1⅞" (48mm)	13¾" (349mm)	X3X-WW(30/3)-12
	4¼" (108mm)	7⅞" (181mm)	1⅞" (48mm)	14⅞" (359mm)	X4X-WW(30/3)-12
	5¼" (133mm)	7⅞" (187mm)	2" (51mm)	14⅞" (372mm)	X5X-WW(30/3)-12
	6¼" (159mm)	7⅞" (194mm)	2" (51mm)	15⅝" (384mm)	X6X-WW(30/3)-12
24" (610mm)	3½" (89mm)	12⅞" (327mm)	3½" (89mm)	24¾" (654mm)	X3X-WW(30/3)-24
	4¼" (108mm)	13⅞" (334mm)	3½" (89mm)	26⅞" (664mm)	X4X-WW(30/3)-24
	5¼" (133mm)	13⅞" (340mm)	3⅝" (92mm)	26⅞" (676mm)	X5X-WW(30/3)-24
	6¼" (159mm)	13⅞" (346mm)	3⅝" (92mm)	27⅞" (689mm)	X6X-WW(30/3)-24
36" (914mm)	3½" (89mm)	18⅞" (480mm)	5⅞" (130mm)	37¾" (959mm)	X3X-WW(30/3)-36
	4¼" (108mm)	19⅞" (486mm)	5⅞" (130mm)	38⅞" (969mm)	X4X-WW(30/3)-36
	5¼" (133mm)	19⅞" (492mm)	5¼" (133mm)	38⅞" (981mm)	X5X-WW(30/3)-36
	6¼" (159mm)	19⅞" (499mm)	5¼" (133mm)	39⅞" (994mm)	X6X-WW(30/3)-36

Example: 24A-1230-12

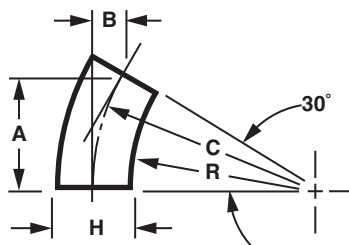

See page 74
for Grounding
Chart Reference

90° VERTICAL CABLE SUPPORT ELBOW (SR)

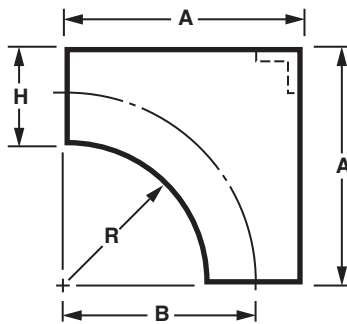
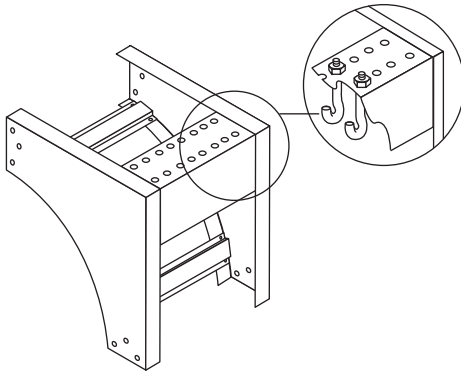

CSA CERTIFIED FOR CSA SYSTEMS

Radius - R	"H" Dim.	"A" Dim.	"B" Dim.	Part Number
12" (305mm)	3½" (89mm)	15½" (394mm)	13¾" (349mm)	X3X-WWSR-12
	4¼" (108mm)	16¼" (413mm)	14⅞" (359mm)	X4X-WWSR-12
	5¼" (133mm)	17¼" (438mm)	14⅞" (371mm)	X5X-WWSR-12
	6¼" (159mm)	18¼" (464mm)	15⅞" (384mm)	X6X-WWSR-12
24" (610mm)	3½" (89mm)	27½" (699mm)	25¾" (654mm)	X3X-WWSR-24
	4¼" (108mm)	28¼" (718mm)	26⅞" (664mm)	X4X-WWSR-24
	5¼" (133mm)	29¼" (743mm)	26⅞" (676mm)	X5X-WWSR-24
	6¼" (159mm)	30¼" (768mm)	27⅞" (689mm)	X6X-WWSR-24
36" (914mm)	3½" (89mm)	39½" (1003mm)	37¾" (959mm)	X3X-WWSR-36
	4¼" (108mm)	40¼" (1022mm)	38⅞" (968mm)	X4X-WWSR-36
	5¼" (133mm)	41¼" (1048mm)	38⅞" (981mm)	X5X-WWSR-36
	6¼" (159mm)	42¼" (1073mm)	39⅞" (994mm)	X6X-WWSR-36

Example: 24A-12SR-12

VERTICAL TEE DOWN [VT] & UP [OT]

CSA CERTIFIED FOR CSA SYSTEMS

Radius - R	"H" Dim.	"A" Dim.	"C" Dim.	"C" Dim.	Part Number
12" (305mm)	3½" (89mm)	27½" (718mm)	15½" (394mm)	13¾" (349mm)	X3X-WW(VT/OT)-12
	4¼" (108mm)	28¼" (743mm)	16¼" (413mm)	14⅞" (359mm)	X4X-WW(VT/OT)-12
	5¼" (133mm)	29¼" (768mm)	17¼" (438mm)	14⅞" (371mm)	X5X-WW(VT/OT)-12
	6¼" (159mm)	30¼" (794mm)	18¼" (464mm)	15⅞" (384mm)	X6X-WW(VT/OT)-12
24" (610mm)	3½" (89mm)	51½" (1327mm)	27½" (699mm)	25¾" (654mm)	X3X-WW(VT/OT)-24
	4¼" (108mm)	52¼" (1353mm)	28¼" (718mm)	26⅞" (664mm)	X4X-WW(VT/OT)-24
	5¼" (133mm)	53¼" (1378mm)	29¼" (743mm)	26⅞" (676mm)	X5X-WW(VT/OT)-24
	6¼" (159mm)	54¼" (1403mm)	30¼" (768mm)	27⅞" (689mm)	X6X-WW(VT/OT)-24
36" (914mm)	3½" (89mm)	75½" (1937mm)	39½" (1003mm)	37¾" (959mm)	X3X-WW(VT/OT)-36
	4¼" (108mm)	76¼" (1962mm)	40¼" (1022mm)	38⅞" (968mm)	X4X-WW(VT/OT)-36
	5¼" (133mm)	77¼" (1988mm)	41¼" (1048mm)	38⅞" (981mm)	X5X-WW(VT/OT)-36
	6¼" (159mm)	78¼" (2013mm)	42¼" (1073mm)	39⅞" (994mm)	X6X-WW(VT/OT)-36

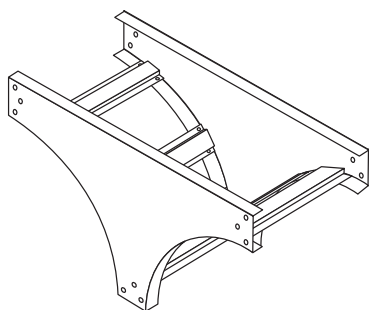

VERTICAL TEE - UP (OT)

Example: 24A-12VT-12

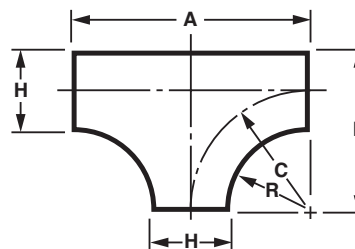
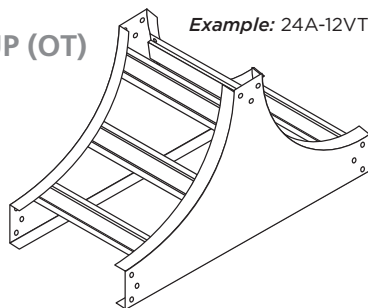

See page 74
for Grounding
Chart Reference

HAT CABLE TRAY SYSTEM

ELECTRICAL GROUNDING CHART

Table 1 below provides the Minimum Cross Sectional area for two side rails. Using the Fitting Prefix Number (24A), the proper value is determined by the Material (column 3), the Flange Width (column 1) and Load Depth (column 2). Locate the line containing the Load Depth (column 1) and follow it to the right to the appropriate Flange Width and Material.

TABLE 1

			Min. X-Sect for 2 Rails (NEC® Table 392.7B)			
			Aluminum		Steel	
Fitting Prefix Number			¹³ / ₁₆ " Flange	1 ¹ / ₄ " Flange	¹³ / ₁₆ " Flange	1 ¹ / ₄ " Flange
Flange	Load Depth	Material	X-Sect Area	X-Sect Area	X-Sect Area	X-Sect Area
2 - ¹³ / ₁₆ "	3"	6 - Mill Gal	0.60	0.60	0.40	0.70
4 - 1 ¹ / ₄ "	4"	7 - HDGAF	0.60	0.60	0.40	0.70
	5"	8 - Alum.	0.60	1.00	0.70	0.70
	6"		0.60	1.00	0.70	1.00

Find that value in Table 2, follow it to the right to the Material column to determine the Maximum Ground Fault Amperage.

TABLE 2

X-Sect Area	Maximum Ground Fault Amperage (in Amps)	
	Aluminum	Steel
.40 sq in	-	100
.60 sq in	1000	-
.70 sq in	-	200
1.00 sq in	1200	400

For Example:

If the fitting prefix is 24A, the Flange is ¹³/₁₆", the Load Depth is 4", and the Material is Aluminum. The Minimum Cross Sectional Area (X-Sect Area) is 0.60 sq. in. The Amperage is 1000.

TYPICAL SPECIFICATIONS

By specifying the NEMA class designation, you will use the simplest, clearest, and most complete method of specification available and automatically incorporate support span in feet, working (allowable) load in pounds per linear foot, a safety factor of 1.5, a concentrated load if present, and, all other design, manufacturing, and test standards including electrical continuity.

All you need to do is add the desired load depth, rung spacing, radius of fittings, metal and finish. You may add accessory information pursuant to your project. Here is a typical specification for an outdoor tray system where the working (allowable) load has been determined to be approximately 75 pounds per foot on support spans of 12'-0".

SPECIFICATION - COPE HAT LADDER SYSTEM

Cable Hat Ladder shall be manufactured by a company regularly engaged in the manufacture of metal cable trays and shall be a member of NEMA. Trays shall conform to NEMA Metal Cable Tray Standard Publication VE-1 (latest issue).

1. Cable ladder shall be NEMA Classification 12B of the widths indicated.
2. Material shall be aluminum alloy 6063-T6 for side rails and 5052-H34 for rungs.
3. Finish shall be natural.
4. Inside load depth to be NEMA Standard 4".
5. Fittings shall be 12" radius for control cables and 24" radius for power cables. (This must be commensurate with the cable manufacturer's recommended minimum bending radius.)
6. All top level trays in stacks, and single runs to have raised peaked, aluminum ventilated covers with heavy duty hold down clamps every 3'-0"
7. Install expansion connectors, expansion guides, and hold down clamps per NEMA Standard VE-1.

8. Where slopes or horizontal bends of trays are not at the Standard NEMA angles, use adjustable connectors. If the angle is too great for cable bending radius, use combinations of fitting and adjustable connectors.

9. Separate all cables of different voltages in the same tray using the manufacturer's standard barriers and barrier hold down system.

10. The Cable Hat Ladder system will be used as an equipment grounding conductor.

11. To save space, fittings shall have no tangents. To facilitate field installation use one pair of universal type connector plates for rigid joints.

12. Cable Ladder to have hat type rungs arc welded to side rails. Rungs shall not protrude below side rails. Outside depth shall not exceed inside depth by more than ⁵/₈". Side rails to have flanges facing in. Trays shall be Cope Hat Ladder System No. 3B4A as manufactured by Atkore International.

5



TROF



Corrugated Bottom Cable TROF System for Power, Control, Instrumentation Cable, & Pneumatic Tubing

CONTENTS

GENERAL & TECHNICAL INFORMATION

Selection Chart: Cope Trof - Aluminum	78 - 79
Selection Chart: Cope Trof - Steel.....	80 - 81
Overview	82
Ordering Information.....	83
CSA Selection Chart: Aluminum/Steel	84
CSA Ordering Information.....	85
Straight Length.....	86

COPE TROF FITTINGS

Horizontal Elbows	
90°	87
60°	87
45°	88
30°	88
Horizontal Tee	89 - 91
Horizontal Cross	89, 92 - 93
Straight Reducers	94
Left and Right Hand Reducers	94
Adjustable Elbow	95
45° “Y” Branch	95
Vertical Elbows (Inside and Outside)	
90°	96
60°	96
45°	97
30°	97
90° Vertical Cable Support Elbow	98
Vertical Tee	98
Typical Specification.....	99
Electrical Grounding Information	100

STRAIGHT LENGTH

Page 86

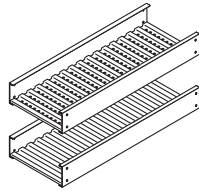

ADJUSTABLE ELBOWS

Page 95

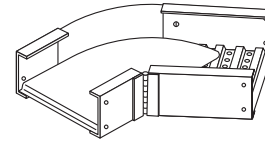

HORIZONTAL ELBOWS

Pages 87 - 88

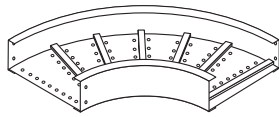

45° "Y" BRANCH

Page 95

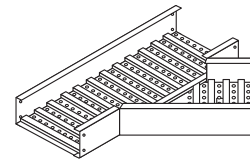

HORIZONTAL TEE

Pages 89 - 91

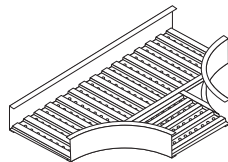

VERTICAL ELBOWS

Pages 96 - 97

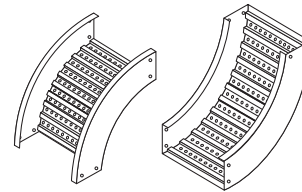

HORIZONTAL CROSS

Pages 89, 92 - 93

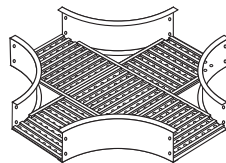

90° VERTICAL CABLE SUPPORT ELBOW

Page 98

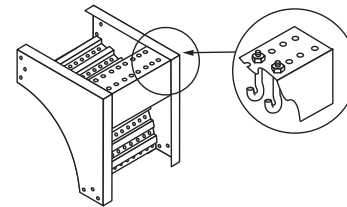

REDUCERS

Page 94

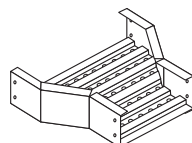

VERTICAL TEE

Page 98

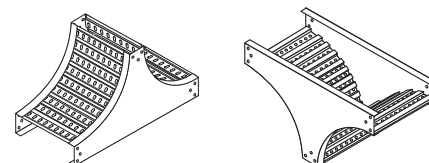

TROF CABLE TRAY SYSTEM

ALUMINUM TRAY

SELECTION CHART

NEMA CLASS, PHYSICAL AND STRUCTURAL PROPERTIES

NEMA Standard VE-1 Load/Span Class	Cope System Number	Cope Systems Certified by CSA	Nominal Load Depth	Side Rail Height	Flange Width (in.)	Section Modulus of 2 Rails Sx (in.3)	Moment of Inertia for 2 Rails Ix (in.4)	Min X-Sect. Area of 2 Rails per NEC 392.7 (in.2)
8A-12A 50 lb./ft. 12' span	5234	-	3" (76mm)	3½" (89mm)	1⅜"	0.800	1.400	0.60
	1B44	1B44	4" (102mm)	4¼" (108mm)	1⅜"	0.898	1.822	0.60
	1B54	1B54	5" (127mm)	5¼" (133mm)	1⅜"	1.142	2.872	0.60
	3B64	-	6" (152mm)	6¼" (159mm)	1⅜"	1.614	4.720	1.00
12B 75 lb./ft. 12' span	3B44	-	4" (102mm)	4¼" (108mm)	1⅜"	1.148	2.316	0.60
	1B54	1B54	5" (127mm)	5¼" (133mm)	1⅜"	1.142	2.872	0.60
	3B64	-	6" (152mm)	6¼" (159mm)	1⅜"	1.614	4.720	0.60
12C 100 lb./ft. 12' span	5B44	-	4" (102mm)	4¾" (108mm)	1⅜"	1.646	3.058	1.00
	3B54	-	5" (127mm)	5¼" (133mm)	1⅜"	1.522	3.734	1.00
	5B64	-	6" (152mm)	6¼" (159mm)	1⅜"	1.944	5.866	1.00
16A 50 lb./ft. 16' span	5B44	-	4" (102mm)	4¼" (108mm)	1⅜"	1.646	3.058	1.00
	7454	7454	5" (127mm)	5¼" (133mm)	1¼"	2.396	6.292	1.50
	1D64	1D64	6" (152mm)	6¼" (159mm)	1¼"	2.378	7.202	1.00
16B 75 lb./ft. 16' span	3D44	3D44	4" (102mm)	4¼" (108mm)	1¼"	2.242	4.406	1.00
	7454	7454	5" (127mm)	5¼" (133mm)	1¼"	2.396	6.292	1.50
	1D64	1D64	6" (152mm)	6¼" (159mm)	1¼"	2.378	7.202	1.00
16C 100 lb./ft. 16' span	5D44	5D44	4" (102mm)	4¼" (108mm)	1¼"	2.782	5.738	1.50
	3D54	3D54	5" (127mm)	5¼" (133mm)	1¼"	3.434	8.746	2.00
	7D64	-	6" (152mm)	6¼" (159mm)	1¼"	4.186	12.024	2.00
20A 50 lb./ft. 20' span	3D44	-	4" (102mm)	4¼" (108mm)	1¼"	2.242	4.406	1.00
	7454	7454	5" (127mm)	5¼" (133mm)	1¼"	2.396	6.292	1.50
	1D64	1D64	6" (152mm)	6¼" (159mm)	1¼"	2.378	7.202	1.00
20B 75 lb./ft. 20' span	3D54	3D54	5" (127mm)	5¼" (133mm)	1¼"	3.434	8.746	2.00
	7D64	7D64	6" (152mm)	6¼" (159mm)	1¼"	4.186	12.024	2.00
20C 100 lb./ft. 20' span	5E44	5E44	4" (102mm)	4¼" (108mm)	1½"	3.716	3.879	2.00
	5D54	-	5" (127mm)	5¼" (133mm)	1¼"	3.910	10.020	2.00
	7D64	7D64	6" (152mm)	6¼" (159mm)	1¼"	4.186	12.024	2.00
EXTRA HEAVY DUTY - VERY LONG SPAN TRAYS - SOLID OR VENTILATED BOTTOMS								
	9D64	-	6" (152mm)	6¼" (159mm)	1¼"	5.130	15.700	2.00
	7G64	-	6" (152mm)	6¼" (159mm)	2"	5.804	17.456	2.00

Note: indicates most common systems. Consult factory for lead times on other systems.

**LOAD AND DEFLECTION DATA FOR ALUMINUM TROF WORKING (ALLOWABLE) LOAD CAPACITY,
EVENLY DISTRIBUTED - TESTED PER NEMA STANDARD VE-1
SPAN (FT.) - SIMPLE BEAM - SAFETY FACTOR: 1.5**

Cope Sys. No.	6 Ft. Span			8 Ft. Span			10 Ft. Span			12 Ft. Span			16 Ft. Span			20 Ft. Span			24 Ft. Span			25 Ft. Span		
	w	d	k	w	d	k	w	d	k	w	d	k	w	d	k	w	d	k	w	d	k	w	d	k
5234	207	0.43	0.002	117	0.77	0.007	75	1.20	0.016	52	1.73	0.033												
1B44	222	0.35	0.002	125	0.63	0.005	80	0.99	0.012	55	1.42	0.026												
1B54	324	0.33	0.001	182	0.59	0.003	117	0.87	0.007	77	1.26	0.016												
3B64	359	0.22	†	191	0.37	0.002	115	0.55	0.005	75	0.74	0.010												
3B44	354	0.45	0.001	191	0.76	0.004	117	1.14	0.010	78	1.57	0.020												
1B54	324	0.33	0.001	182	0.59	0.003	117	0.87	0.007	77	1.26	0.016												
3B64	359	0.22	†	191	0.37	0.002	115	0.55	0.005	75	0.74	0.010												
5B44	362	0.32	†	251	0.69	0.003	161	1.08	0.007	112	1.55	0.014												
3B54	394	0.31	†	222	0.55	0.002	142	0.86	0.006	100	1.24	0.012												
5B64	480	0.24	†	257	0.40	0.002	156	0.60	0.040	102	0.81	0.008												
5B44				251	0.69	0.003	161	1.08	0.007	112	1.55	0.014	51	2.26	0.044	25	2.75	0.110						
7454				349	0.51	0.001	223	0.80	0.004	155	1.15	0.007	79	1.85	0.023	51	2.89	0.057						
1D64				380	0.49	0.001	222	0.69	0.003	154	1.00	0.006	78	1.61	0.021	50	2.51	0.050						
3D44				342	0.72	0.002	219	1.12	0.005	152	1.61	0.011	82	2.74	0.033	52	4.27	0.082						
7454				349	0.51	0.001	223	0.80	0.004	155	1.15	0.007	79	1.85	0.023	51	2.89	0.057						
1D64				380	0.49	0.001	222	0.69	0.003	154	1.00	0.006	78	1.61	0.021	50	2.51	0.050						
5D44				444	0.71	0.002	284	1.10	0.004	188	1.53	0.008	106	2.73	0.026	65	4.07	0.063						
3D54				525	0.55	0.001	336	0.86	0.003	233	1.24	0.005	119	2.01	0.017	76	3.14	0.041						
7D64							404	0.76	0.002	281	1.09	0.004	158	1.94	0.012	101	3.02	0.030						
3D44										152	1.61	0.011	82	2.74	0.033	52	4.27	0.082						
7454										155	1.15	0.007	79	1.85	0.023	51	2.89	0.057						
1D64										154	1.00	0.006	78	1.61	0.021	50	2.51	0.050						
3D54										233	1.24	0.005	119	2.01	0.017	76	3.14	0.041						
7D64										281	1.09	0.004	158	1.94	0.012	101	3.02	0.030						
5E44										298	1.79	0.006	161	3.07	0.019	103	4.79	0.047						
5D54										290	1.35	0.005	156	2.30	0.015	100	3.59	0.036						
7D64										281	1.09	0.004	158	1.94	0.012	101	3.02	0.030						
9D64										412	1.22	0.003	214	2.00	0.009	131	3.01	0.023	68	3.23	0.048			
7G64										451	1.20	0.003	253	2.14	0.008	162	3.35	0.020	112	4.79	0.043	104	5.24	0.05

Note: To convert 1.5 safety factor to 2.0 multiply w, d, k by .75
w=Pounds per linear foot
Metric: for kg/m multiply w by 1.48
d=Deflection (inches)
k=Deflection (in.) for each pound of load
†=Denotes k is less than .001 inch Selection Chart: Steel Tray

TROF CABLE TRAY SYSTEM

STEEL TRAY

SELECTION CHART

NEMA CLASS, PHYSICAL AND STRUCTURAL PROPERTIES

VE-1 Load/ Span Class NEMA Load/Span	System No. Mill Galv	System No. HDGAF	System No. 304 SS	HDGAF Certified by CSA	Nominal Load Depth	Side Rail Height	Flange	Section Modulus of 2 Rails Sx (in.3)	Moment of Inertia for 2 Rails Ix (in.4)	Minimum X-Sect. Area of 2 Rails per NEC 392.7 (in.2)
8A - 12A 50 lb./ft. 12' span	8232	6233	823U	-	3" (76mm)	3½" (89mm)	1 13/16"	0.444	1.378	0.4
	8242	6243	824U	8242/3	4" (102mm)	4¼" (108mm)	1 3/16"	0.592	1.258	0.4
	8252	6253	825U	-	5" (127mm)	5¼" (133mm)	1 3/16"	0.816	2.142	0.4
	8262	6263	826U	8262/3	6" (152mm)	6¼" (159mm)	1 3/16"	1.072	3.352	0.7
12B 75 lb./ft. 12' span	4232	4233	423U	-	3" (76mm)	3½" (89mm)	1 3/16"	0.674	1.180	0.7
	8B42	6B43	8B4U	-	4" (102mm)	4¼" (108mm)	1 3/16"	0.678	1.370	0.4
	8252	6253	825U	-	5" (127mm)	5¼" (133mm)	1 3/16"	0.816	2.142	0.4
	8262	6263	826U	8262/3	6" (152mm)	6¼" (159mm)	1 3/16"	1.072	3.352	0.7
12C 100 lb./ft. 12' span	6B42	6B43	6B4U	-	4" (102mm)	4¼" (108mm)	1 3/16"	0.834	1.690	0.7
	6B52	6B53	6B5U	-	5" (127mm)	5¼" (133mm)	1 3/16"	1.14	2.872	0.7
	6262	6263	626U	-	6" (152mm)	6¼" (159mm)	1 3/16"	1.33	4.158	0.7
16A 50 lb./ft. 16' span	8D42	6D43	8D4U	-	4" (102mm)	4¼" (108mm)	1 ¼"	0.852	1.736	0.4
	6452	6453	645U	6452/3	5" (127mm)	5¼" (133mm)	1 ¼"	1.28	3.360	0.7
	6462	6463	646U	6462/3	6" (152mm)	6¼" (159mm)	1 ¼"	1.652	5.160	0.7
16B 75 lb./ft. 16' span	6D42	6D43	6D4U	-	4" (102mm)	4¼" (108mm)	1 ¼"	1.056	2.152	0.7
	6452	6453	645U	6452/3	5" (127mm)	5¼" (133mm)	1 ¼"	1.28	3.360	0.7
	6462	6463	646U	6462/3	6" (152mm)	6¼" (159mm)	1 ¼"	1.652	5.160	0.7
16C 100 lb./ft. 16' span	4D42	4D43	4D4U	-	4" (102mm)	4¼" (108mm)	1 ¼"	1.298	2.652	1.0
	6452	6453	645U	6452/3	5" (127mm)	5¼" (133mm)	1 ¼"	1.28	3.360	0.7
	6462	6463	646U	6462/3	6" (152mm)	6¼" (159mm)	1 ¼"	1.652	5.160	0.7
20A 50 lb./ft. 20' span	6D42	6D43	6D4U	-	4" (102mm)	4¼" (108mm)	1 ¼"	1.056	2.152	0.7
	6452	6453	645U	6452/3	5" (127mm)	5¼" (133mm)	1 ¼"	1.28	3.360	0.7
	6462	6463	646U	6462/3	6" (152mm)	6¼" (159mm)	1 ¼"	1.652	5.160	1.0
20B 75 lb./ft. 20' span	2D42	2D43	2D4U	-	4" (102mm)	4¼" (108mm)	1 ¼"	1.758	3.604	1.0
	4D52	4D53	4D5U	4D52/3	5" (127mm)	5¼" (133mm)	1 ¼"	1.744	4.418	1.0
	6D62	6D63	6D6U	-	6" (152mm)	6¼" (159mm)	1 ¼"	1.814	5.486	1.0
20C 100 lb./ft. 20' span	2D52	2D53	2D5U	-	5" (127mm)	5¼" (133mm)	1 ¼"	2.37	6.026	1.5
	4D62	4D63	4D6U	4D62/3	6" (152mm)	6¼" (159mm)	1 ¼"	2.24	6.778	1.0
EXTRA HEAVY DUTY - VERY LONG SPAN TRAYS - SOLID OR VENTILATED BOTTOMS										
	2D62	2D63	2D6U	-	6" (152mm)	6¼" (159mm)	1 ¼"	3.056	9.270	1.5
	11D62	11D63	11D6U	-	6" (152mm)	6¼" (159mm)	1 ¼"	3.536	10.630	1.5

Note: Indicates most common systems. Consult factory for lead times on other systems.

**LOAD AND DEFLECTION DATA FOR STEEL TROF
WORKING (ALLOWABLE) LOAD CAPACITY, EVENLY DISTRIBUTED-TESTED PER NEMA STANDARD VE-1
SPAN (FT.) - SIMPLE BEAM - SAFETY FACTOR: 1.5**

Cope Sys. No.	6 Ft. Span			8 Ft. Span			10 Ft. Span			12 Ft. Span			16 Ft. Span			20 Ft. Span			24 Ft. Span			25 Ft. Span		
	w	d	k	w	d	k	w	d	k	w	d	k	w	d	k	w	d	k	w	d	k	w	d	k
8232/3/U	230	0.30	0.001	126	0.52	0.004	79	0.79	0.010	53	1.11	0.021												
8242/3/U	292	0.23	†	164	0.42	0.003	103	0.63	0.006	69	0.89	0.013												
8252/3/U	383	0.18	†	210	0.31	0.001	127	0.46	0.004	83	0.62	0.007												
8262/3/U	357	0.11	†	194	0.18	†	119	0.28	0.002	79	0.38	0.005												
4232/3/U	358	0.30	†	197	0.53	0.003	124	0.81	0.007	83	1.13	0.014												
8B42/3/U	360	0.26	†	198	0.46	0.002	124	0.70	0.006	84	0.98	0.012												
8252/3/U	383	0.18	†	210	0.31	0.001	127	0.46	0.004	83	0.62	0.007												
8262/3/U	357	0.11	†	194	0.18	†	119	0.28	0.002	79	0.38	0.005												
6B42/3/U	453	0.27	†	249	0.47	0.002	156	0.71	0.005	106	1.00	0.009												
6B52/3/U	591	0.21	†	325	0.36	0.001	203	0.55	0.003	137	0.77	0.006												
6262/3/U	460	0.11	†	250	0.19	†	154	0.29	0.002	103	0.40	0.004												
8D42/3/U				290	0.53	0.002	182	0.81	0.004	126	1.17	0.009	65	1.91	0.029									
6452/3/U				444	0.42	†	273	0.63	0.002	186	0.89	0.005	100	1.51	0.015									
6462/3/U				574	0.42	†	367	0.55	0.001	245	0.76	0.003	123	1.22	0.010									
6D42/3/U				381	0.56	0.001	244	0.88	0.004	169	1.27	0.008	88	2.08	0.024									
6452/3/U				444	0.42	†	273	0.63	0.002	186	0.89	0.005	100	1.51	0.015									
6462/3/U				574	0.42	†	367	0.55	0.001	245	0.76	0.003	123	1.22	0.010									
4D42/3/U				487	0.58	0.001	312	0.91	0.003	216	1.31	0.006	113	2.16	0.019									
6452/3/U				444	0.42	†	273	0.63	0.002	186	0.89	0.005	100	1.51	0.015									
6462/3/U				574	0.42	†	367	0.55	0.001	245	0.76	0.003	123	1.22	0.010									
6D42/3/U										169	1.27	0.008	88	2.08	0.024	52	2.98	0.057						
6452/3/U										186	0.89	0.005	100	1.51	0.015	53	1.94	0.037						
6462/3/U										245	0.76	0.003	123	1.22	0.010	66	1.59	0.024						
2D42/3/U										304	1.36	0.004	159	2.24	0.014	94	3.23	0.034						
4D52/3/U										280	1.02	0.004	145	1.67	0.012	85	2.40	0.028						
6D62/3/U										269	0.80	0.003	139	1.28	0.009	81	1.82	0.022						
2D52/3/U										395	1.05	0.003	206	1.74	0.008	121	2.50	0.021						
4D62/3/U										296	0.79	0.003	152	1.28	0.008	105	1.91	0.018						
2D62/3/U										390	0.85	0.002	221	1.40	0.006	149	2.00	0.013	79	1.91	0.024	73	2.38	0.033
11D62/3/U										434	0.66	†	244	1.17	0.005	156	1.82	0.012	108	2.62	0.024	100	2.85	0.029

Note: To convert 1.5 safety factor to 2.0 multiply w, d, k by .75
w = Pounds per linear foot
Metric: for kg/m multiply by 1.48
d = Deflection (inches)
k = Deflection (in.) for each pound of load
† = Denotes k is less than .001 inch

TROF CABLE TRAY SYSTEM

OVERVIEW

COPE TROF is a prefabricated metal structure consisting of ventilated or solid bottoms, welded to the side rails, and are manufactured and tested to NEMA Standard VE-1. Straight sections, fittings (elbows, tees, crosses, reducers, etc.) and a full line of matching and interfacing accessories are available. Corrugations give great lateral rigidity to the bottom transmitting the load to the side rails. Lateral (transverse) deflection is nearly eliminated compared to rung type trofs where the rails are not continuously braced by the bottom.

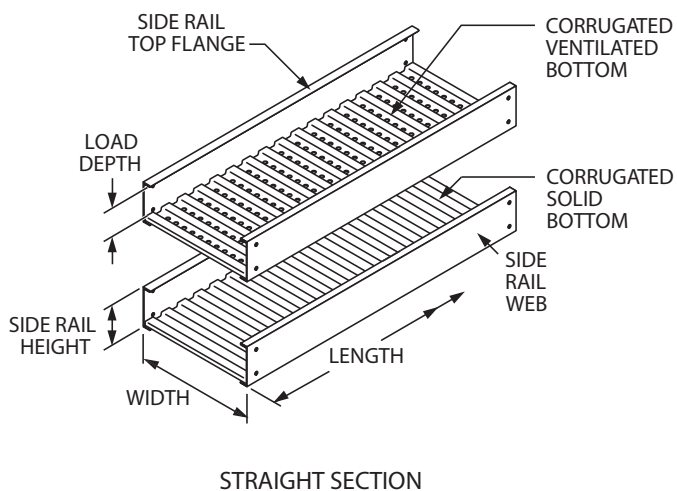

Cope Corrugated bottoms do NOT limit the tray load capacity. Corrugated bottoms have 1" wide ribs on 2" centers. Ventilation holes in the valleys of the corrugations are $\frac{1}{16}$ " diameter on one inch (1") centers. Free passage of air through the openings results in a 68% open area at the elevated cable support surface on top of ribs. Solid Trof have the same corrugations but have no holes.

Note: Where drain holes are required, one can be placed in the center of each valley, if specified.

COPE TROF WITH Three IMPORTANT INDUSTRY-LEADING FEATURES:

1. New Universal Curvilinear Splice Plate System

The splice plates for rigid connections have a slight curve so they can be used on straight sections or fittings. Tightening of the fastener pulls the plate flush with the side rail. The fasteners are snug and the joint is structurally and electrically superior. Even when hand-tightened, there is pressure on the fastener to hold it securely.

Note: Heavy Duty, Mid Span Splice Plates available upon request.

2. Zero Tangent Fittings

Tangent as referred to on cable tray fittings is the straight at the end of the curve to accommodate a flat splice plate. This wastes space in tightly packed areas, such as spreader rooms, where the heat of thousands of cables accumulate. Eliminating tangents allow more tray runs to distribute the heat. COPE ZERO TANGENT FITTINGS CAN SAVE UP TO 12" PER ROW OF TRAY.

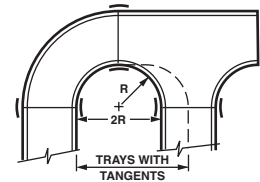

BONUS: Inspection for proper installation of splice plate is visual. If the plate is bowed away from the rail, nuts must be tightened.

3. The Exclusive Auto Arc-Welded Assembly System

Corrugated bottoms on straight sections are assembled to the side rails using an automatic, self indexing MIG-arc-welding system fusing a $\frac{1}{2}$ " diameter zone. These welds are 700% larger and stronger than the common resistance (spot) weld in use today. Electrical properties of the assembly are unequalled; are well within the NEMA requirements due to the continuous electrical path. The mechanical strength of this welded assembly withstands the rigors of shipping, handling, installation and service. The size of the weld keeps the vertical axis of the side rail from sloping inward under load. The weld maintains the 90° angle between the side rail and bottom. This allows full use of the section properties. Spot welds do not permit this. Also, stresses on spot welds (barely $\frac{1}{8}$ " in diameter) are so severe that breakage often occurs during shipping and installation. Cope Trof fittings are also assembled by MIG-arc-welding.

USES OF COPE TROF

Generally, Cope Trof is optimum for ANY size cable. It offers continuous support with or without ventilation. The bottom design offers safety and security from unauthorized personnel. The vent holes may be bushed with a grommet for dropping out communication cables (Cat. DOG-2).

PART NUMBERING SYSTEM:

STRAIGHT LENGTH

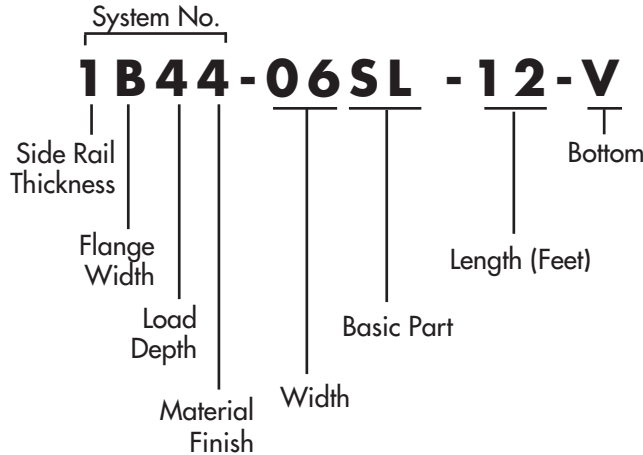

SYSTEM NUMBER (STRAIGHT SECTION ONLY)-

The first four digits make up the system number which identifies the structural, dimensional, and material characteristics of the straight length. It is made up of the side rail digits indicating the side rail thickness and flange width, the load depth (inside, in inches), and material finish (galvanized, aluminum or coated).

PREFIX NUMBER (FITTINGS ONLY) - Fittings are ordered using the 3-digit prefix number given in the charts on the fitting pages. Fittings do not have stiffened upper flanges.

WIDTH - Identifies the inside width of the tray in inches.

SYSTEM STRAIGHT SECTION ONLY

Thickness Steel (Ga.)	Flange Width	Load Depth		Material Finish
8 - 18 ga.	2 - 1 ³ / ₁₆ "	(21mm)	3" (76mm)	2 - Mill-Galv.
6 - 16 ga.	4 - 1 ¹ / ₄ "	(32mm)	4" (102mm)	3 - HDGAF
4 - 14 ga.	5 - 1 ¹ / ₂ "	(38mm)	5" (127mm)	4 - Aluminum
2 - 12 ga.	7 - 2"	(51mm)	6" (152mm)	U - 304SS
11 - 11 ga.				
Thickness Alum (in.)				
1 - Thinner	B - 1 ³ / ₁₆ "	(21mm)		
3 -	D - 1 ¹ / ₄ "	(32mm)		
5 -**	E - 1 ¹ / ₂ "	(38mm)		
7 -	G - 2"	(51mm)		
9 - Thicker				

**Alum. extruded side rails are individually engineered to loads and spans.
Slotted Rungs provided on trays 6", 9", 12", 18", and 24" wide
Solid Rungs provided on trays 30" and 36" wide.

FITTINGS

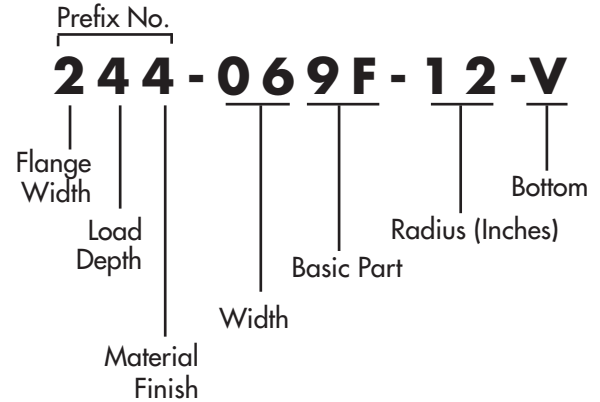

BASIC PART NUMBER - Identifies the straight length, fitting, or accessory.

SECONDARY DIMENSION NUMBER - Identifies the length of a straight section in feet, the radius of a fitting in inches, or the second width of a reducer in inches.

BOTTOM TYPE- Identifies the type bottom: V (Ventilated) or S (Solid). Example: 1B44-06SL-12-V is a 4" load depth aluminum Trof with a 1³/₁₆" flange, 6" wide, straight length 12' long with a ventilated bottom.

SYSTEM FITTINGS

Width (in.)	Basic Part Number	Length	Bottom
06=6" (152mm)	SL (Straight Len.)	- 12' (3.7m)	-V (ventilated) -S (solid)
09=9" (229mm)	9F (90° Horiz. El.)	- 24' (7.3m)	
12=12" (305mm)	6F (60° Horiz. El.)	- 10' (3m, CSA)	
18=18" (457mm)	4F (45° Horiz. El.)	- 20' (6m, CSA)	
24=24" (610mm)	3F (30° Horiz. El.)		
30=30" (762mm)	90 (90° Out. Vert. El.)		
36=36" (914mm)	60 (60° Out. Vert. El.)		
	40 (45° Out. Vert. El.)		
	30 (30° Out. Vert. El.)		
	9I (90° In. Vert. El.)		Radius (in.)
	6I (60° In. Vert. El.)		12=12" (305mm)
	4I (45° In. Vert. El.)		24=24" (610mm)
	3I (30° In. Vert. El.)		36=36" (914mm)
	FT (Horiz. Tee)		
	FC (Horiz. Cross)		
	VT (Vert. Tee)		
	SR (Vert. Cable Support Elbow)		
	ST (Straight Reducer)		
	RH (Right Hand Reducer)		
	LH (Left Hand Reducer)		
	AF (Adjustable Elbow)		
	RY & LY (45° "Y" Branch)		

TROF CABLE TRAY SYSTEM

CSA ORDERING INFORMATION

COPE CSA STANDARDS C22-2 CABLE TROF VENTILATED & SOLID BOTTOM TYPE

HOW TO ORDER:

Explanation of Cope's Canadian Standards cable tray catalog numbers is described below. Use the system numbers given in selection charts for straight sections, or the fitting prefix numbers given in fitting tables. Be sure to follow system number or the fitting prefix with the item "description" number. The list below gives the CSA certified items carrying the CSA label.

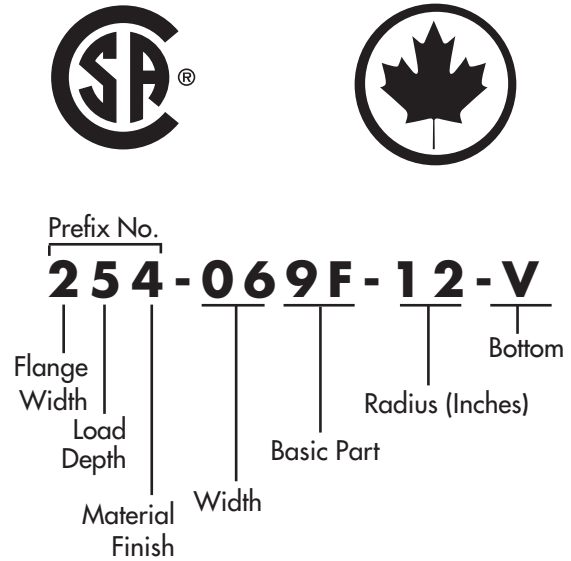
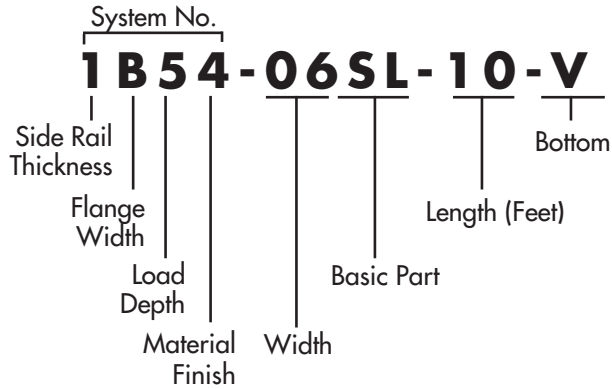

SYSTEM NUMBER (STRAIGHT SECTION ONLY) -

The first four digits make up the system number which identifies the structural, dimensional, and material characteristics of the straight length. It is made up of the side rail digits indicating the side rail thickness and flange width, the load depth (inside, in inches), and material finish (galvanized, aluminum or coated).

PREFIX NUMBER (FITTINGS ONLY) - Fittings are ordered using the 3-digit prefix number given in the charts on the fitting pages. Fittings do not have stiffened upper flanges.

WIDTH - Identifies the inside width of the tray (in inches).

BASIC PART NUMBER - Identifies the straight length, fitting, or accessory.

SECONDARY DIMENSION NUMBER - Identifies the length of a straight section (in feet), the radius of a fitting (in inches), or the second width of a reducer (in inches).

BOTTOM TYPE - Identifies the type bottom: V (Ventilated) or S (Solid)

CSA STRAIGHT LENGTH SYSTEM NUMBER

Thickness Steel (Ga.)	Flange Width	Load Depth	Material Finish
8 - 18 ga.	2 - 13/16"	(21mm) 4"	3 - HDGAF, CSA Class 1
6 - 16 ga.	4 - 1 1/4"	(32mm) 5"	4 - Aluminum Plain Finish
4 - 14 ga.	6"	(152mm)	
Thickness Alum (in.)**			
1 - thinner	*B - 13/16"	(21mm)	
3 -	*D - 1 1/4"	(32mm)	
5 - **	*E - 1 1/2"	(38mm)	
7 -			
9 - thicker			

**Alum. extruded side rails are individually engineered to loads and spans.

DESCRIPTION FITTINGS

Width (in.)	Basic Part No.	Length	Bottom
06=6"	(152mm)	SL (Straight Length)	10 - 10' -V (ventilated)
09=9"	(229mm)	9F (90° Horiz. Elbow)	20 - 20' -S (solid)
12=12"	(305mm)	6F (60° Horiz. Elbow)	
18=18"	(457mm)	4F (45° Horiz. Elbow)	
24=24"	(610mm)	3F (30° Horiz. Elbow)	
30=30"	(762mm)	90 (90° Out. Vert. Elbow)	
36=36"	(914mm)	60 (60° Out. Vert. Elbow)	
		40 (45° Out. Vert. Elbow)	
		30 (30° Out. Vert. Elbow)	
		9I (90° In. Vert. Elbow)	
		6I (60° In. Vert. Elbow)	
		4I (45° In. Vert. Elbow)	
		3I (30° In. Vert. Elbow)	
		FT (Horiz. Tee)	
		FC (Horiz. Cross)	
		VT (Vert. Tee)	
		SR (Vert. Cable Support Elbow)	
		ST (Straight Reducer)	
		RH (Right Hand Reducer)	
		LH (Left Hand Reducer)	
		AF (Adjustable Elbow)	
		RY & LY (45° "Y" Branch)	
		AF (Adjustable Elbow)	
		RY & LY (45° "Y" Branch)	

Radius (in.)

12=12"
24=24"
36=36"



CERTIFIED COPE SYSTEMS THAT MEET PERFORMANCE CLASS CSA STD.C22.2

CSA Class	Cope System	Load Depth	Side Rail	Flange Width	Max. Load Kg/m (lb/ft)	Maximum Support Span	Deflection at Max Support Span	Meets CSA Elec. Tests
ALUMINUM TROF TRAY - Safety Factor: 1.5								
C	1B44	4" (102mm)	4¼" (108mm)	⅜" (21mm)	97 (65)	3m	25.1mm	Yes
20A	3D44	4" (102mm)	4¼" (108mm)	1¼" (32mm)	74 (50)	6m (1)	108.5mm	Yes
16C	5D44	4" (102mm)	4¼" (108mm)	1¼" (32mm)	149 (100)	4.9m	71.4mm	Yes
20C	5E44	4" (102mm)	4¼" (108mm)	1½" (38mm)	149 (100)	6m (1)	121.7mm	Yes
C	1B54	5" (127mm)	5¼" (133mm)	⅜" (21mm)	97 (65)	3m	22.1mm	Yes
20A	7454	5" (127mm)	5¼" (133mm)	1¼" (32mm)	74 (50)	6m (1)	73.4mm	Yes
20B	3D54	5" (127mm)	5¼" (133mm)	1¼" (32mm)	112 (75)	6m (1)	78.7mm	Yes
20A	1D64	6" (152mm)	6¼" (159mm)	1¼" (32mm)	74 (50)	6m (1)	63.8mm	Yes
20C	7D64	6" (152mm)	6¼" (159mm)	1¼" (32mm)	149 (100)	6m (1)	76.7mm	Yes
Mil Gal STEEL TROF TRAY - Safety Factor: 1.5								
C	8242	3¾" (95mm)	4¼" (108mm)	⅜" (21mm)	97 (65)	3m	16.0mm	Yes
20A	6452	5" (127mm)	5¼" (133mm)	1¼" (32mm)	74 (50)	6m (1)	49.3mm	Yes
20B	4D52	5" (127mm)	5¼" (133mm)	1¼" (32mm)	112 (75)	6m (1)	61.0mm	Yes
12B	8262	6" (152mm)	6¼" (159mm)	⅜" (21mm)	112 (75)	3.7m	9.7mm	Yes
20A	6462	6" (152mm)	6¼" (159mm)	1¼" (32mm)	74 (50)	6m (1)	40.4mm	Yes
20C	4D62	6" (152mm)	6¼" (159mm)	1¼" (32mm)	149 (100)	6m	48.5mm	Yes
HDGAF STEEL TROF TRAY - Safety Factor: 1.5								
C	8243	3¾" (95mm)	4¼" (108mm)	⅜" (21mm)	97 (65)	3m	16.0mm	Yes
20A	6453	5" (127mm)	5¼" (133mm)	1¼" (32mm)	74 (50)	6m (1)	49.3mm	Yes
20B	4D53	5" (127mm)	5¼" (133mm)	1¼" (32mm)	112 (75)	6m (1)	61.0mm	Yes
12B	8263	6" (152mm)	6¼" (159mm)	⅜" (21mm)	112 (75)	3.7m	9.7mm	Yes
20A	6463	6" (152mm)	6¼" (159mm)	1¼" (32mm)	74 (50)	6m (1)	40.4mm	Yes
20C	4D63	6" (152mm)	6¼" (159mm)	1¼" (32mm)	149 (100)	6m	48.5mm	Yes

Notes: (1) Also recommended for 3 meter support spans

Note: indicates most common systems. Consult factory for lead times on other systems.

CSA Loads

Identify the desired load designation needed for your project from the chart below. Both CSA Class and NEMA designations are listed by load capability and span. Then, select the CSA Certified Cope System from the table above. Where CSA C22.2 is not mandatory, you may want to consider one of the other Cope systems offered on the selection charts (page 142 thru 143).

HISTORICAL LOAD/SPAN CLASS DESIGNATION

Load, kg/m (lb/ft)	Span, m (ft)				
	2.4 (8)	3.0 (10)	3.7 (12)	4.9 (16)	6.0 (20)
37 (25)	-	A	-	-	-
67 (45)	-	-	-	-	D
74 (50)	8A	-	12A	16A	20A
97 (65)	-	C	-	-	-
112 (75)	8B	-	12B	16B	E or 20B
149 (100)	8C	-	12C	16C	20C
179 (120)	-	D	-	-	-
299 (200)	-	E	-	-	-

Note: 8A/B/C, 12A/B/C, 16A/B/C, and 20A/B/C have been NEMA designations. A, B, C, D and E have been CSA designations

Receiving, Installing, and Maintenance

The proper care and handling of cable Trofs by the receiver and installers is very important to insure a safe installation that will meet the intended service life. Cope has an installation guide available to assist the installers and those who will maintain the installed system.

Dimensions and Structural Properties: Cope CSA Systems

The performance of the Cope cable Trof systems certified by CSA is given above. Structural properties of straight sections, though not required to be listed, are given in the Cope NEMA selection charts, in English units. Dimensions of straight sections and certified fittings are furnished in English and metric units for use in layout and/or entry into computerized systems.

Note: For other CSA approved systems please contact the factory.

TROF CABLE TRAY SYSTEM

STRAIGHT LENGTH [SL]

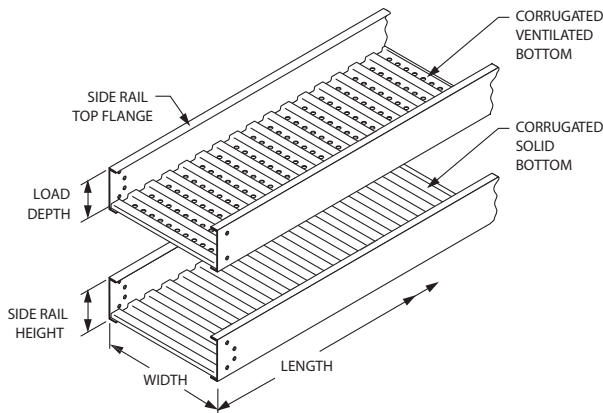

COPE TROF is manufactured in 10' (CSA), 12', 20' (CSA) and 24' lengths; 6", 9", 12", 18", 24", 30" and 36" widths; and, 3", 4", 5", and 6" nominal load depths. A complete line of fittings and accessories are available.

Corrugated bottoms have 1" wide ribs on 2" centers. Ventilation holes in the valleys of the corrugations are 1/16" diameter on one inch (1") centers. Free passage of air through the openings results in a 68% open area. Corrugations give great lateral rigidity to the bottom transmitting the load to the side rails.

Solid Trof have the same corrugations but have no holes. Materials: Aluminum, Hot Dip-Mill galvanized (pre-galvanized) to ASTM A-924, Hot Dip Galvanized after Fabrication (HDGAF) to ASTM A-123.

Sufficient connectors are supplied to assemble straight sections and fittings for each order. Connectors for field cuts to be ordered separately.

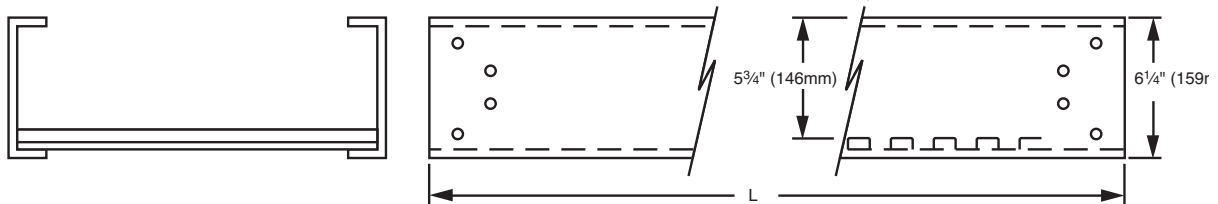

CATALOG NUMBER

System	Width	Basic No.	Length	Bottom Type
See Pages 136 to 139	-06=6" (152mm)	SL	NEMA	-S (solid)
	-09=9" (229mm)			-V (ventilated)
	-12=12" (305mm)		12' (3.7m)*	24' (7.3m)*
	-18=18" (457mm)		10' (3m)*	
	-24=24" (610mm)		20' (6m)*	CSA
	-30=30" (762mm)		-10' (3m)	
	-36=36" (914mm)		-20' (6m)	

*10', 12' all NEMA Classes, 20', 24' NEMA Classes 16A, 16B, 16C, 20A, 20B, 20C.

Example: 1B44-06SL-12-V is a 4" load depth aluminum Trof with 1/16" flange, 6" wide, 12' long, with ventilated bottom.

CONVERSION TABLE

English	6"	9"	12"	18"	24"	30"	36"	12'-0"	24'-0"	10'-0"	20'-0"
Metric (mm)	152	229	305	457	610	762	914	3658	7316	3048	6096

MATERIAL & FINISH SPECIFICATIONS (COPE TROF)

	Pre-Galvanized Steel	Hot-Dip Galvanized after Fabrication ASTM A-123	Aluminum	Type 304 Stainless Steel
Siderails	ASTM A-653-G90 CS (18 & 16 Gage) ASTM A-653-G90 CS (14 & 12 Gage)	ASTM A-1008 (18 & 16 Gage) ASTM A-1011 (14 & 12 Gage)	AA-6063-T6 Extruded	ASTM A-240; Type 304
Bottom	ASTM A-653-G90 CS	ASTM A-1008	AA-6063-H34	ASTM A-269; Type 304
Splice Plate Finish	ASTM A-1011	ASTM A-1011	AA-5052-H34	ASTM A-240; Type 304
	ASTM A-591 Class C	ASTM A-123 Grade 65	2B Finish (Typical)	
Connector	SAE J429 Grade 1	SAE J429 Grade 1	SAE J429 Grade 1	
Bolts	(ASTM A-307 Grade A)	(ASTM A-307 Grade A)	(ASTM A-307 Grade A)	AISI Type 304 Stainless Steel
Bolt Plating	ASTM B-633.0002" Zinc	ASTM B-633.0002" Zinc	ASTM B-633.0002" Zinc	
Covers	ASTM A-653-G90 CQ	ASTM A-653-G90 CQ	AA-3003 H14 or 3150 H14	ASTM A-240; Type 304

90° HORIZONTAL ELBOW [9F]

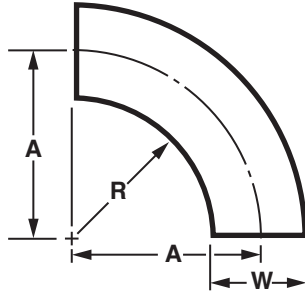
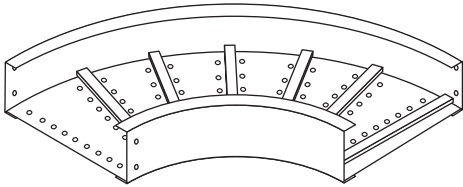

CSA CERTIFIED FOR CSA SYSTEMS

Radius - R	Width - W	"A" Dimension	Part Number
12" (305mm)	6" (152mm)	15" (381mm)	XXX-069F-12-B
	9" (229mm)	16½" (419mm)	XXX-099F-12-B
	12" (305mm)	18" (457mm)	XXX-129F-12-B
	18" (457mm)	21" (533mm)	XXX-189F-12-B
	24" (610mm)	24" (610mm)	XXX-249F-12-B
	30" (762mm)	27" (686mm)	XXX-309F-12-B
	36" (914mm)	30" (762mm)	XXX-369F-12-B
24" (610mm)	6" (152mm)	27" (686mm)	XXX-069F-24-B
	9" (229mm)	28½" (724mm)	XXX-099F-24-B
	12" (305mm)	30" (762mm)	XXX-129F-24-B
	18" (457mm)	33" (838mm)	XXX-189F-24-B
	24" (610mm)	36" (914mm)	XXX-249F-24-B
	30" (762mm)	39" (991mm)	XXX-309F-24-B
	36" (914mm)	42" (1067mm)	XXX-369F-24-B
36" (914mm)	6" (152mm)	39" (991mm)	XXX-069F-36-B
	9" (229mm)	40½" (1029mm)	XXX-099F-36-B
	12" (305mm)	42" (1067mm)	XXX-129F-36-B
	18" (457mm)	45" (1143mm)	XXX-189F-36-B
	24" (610mm)	48" (1219mm)	XXX-249F-36-B
	30" (762mm)	51" (1295mm)	XXX-309F-36-B
	36" (914mm)	54" (1372mm)	XXX-369F-36-B

*Add Suffix -V (vented) or -S (solid) to catalog number.

Example: 234-129F-12-V

Note: When small or in-between angles are needed, use Cope's Adjustable Connectors.

60° HORIZONTAL ELBOW [6F]

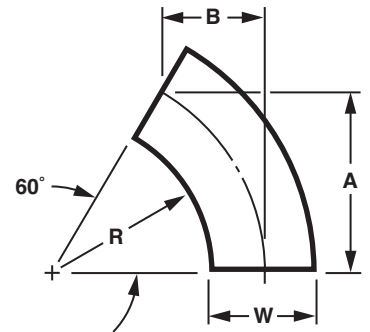
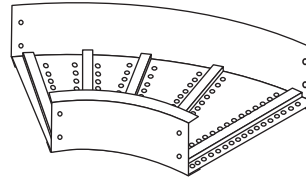

CSA CERTIFIED FOR CSA SYSTEMS

Radius - R	Width - W	"A" Dimension	"B" Dimension	Part Number
12" (305mm)	6" (152mm)	13" (330mm)	7½" (191mm)	XXX-066F-12-B
	9" (229mm)	14¼" (362mm)	8¼" (210mm)	XXX-096F-12-B
	12" (305mm)	15⅝" (397mm)	9" (229mm)	XXX-126F-12-B
	18" (457mm)	18¼" (464mm)	10½" (267mm)	XXX-186F-12-B
	24" (610mm)	20¾" (527mm)	12" (305mm)	XXX-246F-12-B
	30" (762mm)	23⅜" (594mm)	13½" (343mm)	XXX-306F-12-B
	36" (914mm)	26" (660mm)	15" (381mm)	XXX-366F-12-B
24" (610mm)	6" (152mm)	23⅜" (594mm)	13½" (343mm)	XXX-066F-24-B
	9" (229mm)	24¾" (629mm)	14¼" (362mm)	XXX-096F-24-B
	12" (305mm)	26" (660mm)	15" (381mm)	XXX-126F-24-B
	18" (457mm)	28⅝" (727mm)	16½" (416mm)	XXX-186F-24-B
	24" (610mm)	31¼" (794mm)	18" (457mm)	XXX-246F-24-B
	30" (762mm)	33¾" (857mm)	19½" (495mm)	XXX-306F-24-B
	36" (914mm)	36⅝" (924mm)	21" (533mm)	XXX-366F-24-B
36" (914mm)	6" (152mm)	33¾" (857mm)	19½" (495mm)	XXX-066F-36-B
	9" (229mm)	35⅝" (892mm)	20¼" (514mm)	XXX-096F-36-B
	12" (305mm)	36⅝" (924mm)	21" (533mm)	XXX-126F-36-B
	18" (457mm)	39" (991mm)	22½" (572mm)	XXX-186F-36-B
	24" (610mm)	41⅝" (1057mm)	24" (610mm)	XXX-246F-36-B
	30" (762mm)	44⅞" (1121mm)	25½" (648mm)	XXX-306F-36-B
	36" (914mm)	46¾" (1187mm)	27" (686mm)	XXX-366F-36-B

*Add suffix -V (vented) or -S (solid) to catalog number.

Example: 234-126F-12-V

TROF CABLE TRAY SYSTEM

45° HORIZONTAL ELBOW [4F]

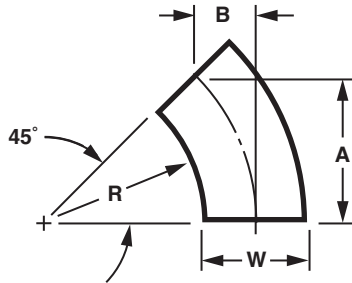
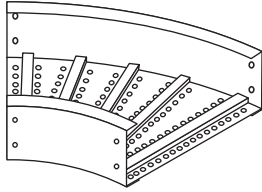

30° HORIZONTAL ELBOW [3F]

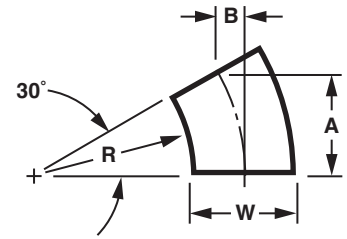
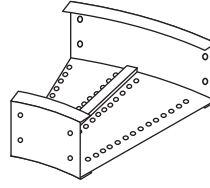

CSA CERTIFIED FOR CSA SYSTEMS

Radius - R	Width - W	"A" Dimension	"B" Dimension	Part Number
12" (305mm)	6" (152mm)	10 ⁵ / ₈ " (270mm)	4 ⁵ / ₈ " (111mm)	XXX-064F-12-B
	9" (229mm)	11 ¹ / ₈ " (295mm)	4 ⁷ / ₈ " (124mm)	XXX-094F-12-B
	12" (305mm)	12 ³ / ₄ " (324mm)	5 ¹ / ₄ " (133mm)	XXX-124F-12-B
	18" (457mm)	14 ⁷ / ₈ " (378mm)	6 ¹ / ₈ " (156mm)	XXX-184F-12-B
	24" (610mm)	17" (432mm)	7" (178mm)	XXX-244F-12-B
	30" (762mm)	19 ¹ / ₈ " (486mm)	7 ⁷ / ₈ " (200mm)	XXX-304F-12-B
	36" (914mm)	21 ¹ / ₄ " (540mm)	8 ³ / ₄ " (222mm)	XXX-364F-12-B
24" (610mm)	6" (152mm)	19 ¹ / ₈ " (486mm)	7 ⁷ / ₈ " (200mm)	XXX-064F-24-B
	9" (229mm)	20 ¹ / ₈ " (511mm)	8 ³ / ₈ " (213mm)	XXX-094F-24-B
	12" (305mm)	21 ¹ / ₄ " (540mm)	8 ³ / ₄ " (222mm)	XXX-124F-24-B
	18" (457mm)	23 ³ / ₈ " (594mm)	9 ⁵ / ₈ " (244mm)	XXX-184F-24-B
	24" (610mm)	25 ¹ / ₂ " (702mm)	10 ¹ / ₂ " (267mm)	XXX-244F-24-B
	30" (762mm)	27 ⁵ / ₈ " (702mm)	11 ¹ / ₂ " (292mm)	XXX-304F-24-B
	36" (914mm)	29 ³ / ₄ " (756mm)	12 ³ / ₈ " (314mm)	XXX-364F-24-B
36" (914mm)	6" (152mm)	27 ⁵ / ₈ " (702mm)	11 ¹ / ₂ " (292mm)	XXX-064F-36-B
	9" (229mm)	28 ⁵ / ₈ " (727mm)	11 ⁷ / ₈ " (302mm)	XXX-094F-36-B
	12" (305mm)	29 ³ / ₄ " (756mm)	12 ³ / ₈ " (314mm)	XXX-124F-36-B
	18" (457mm)	31 ¹ / ₈ " (810mm)	13 ¹ / ₄ " (337mm)	XXX-184F-36-B
	24" (610mm)	34" (864mm)	14 ¹ / ₈ " (359mm)	XXX-244F-36-B
	30" (762mm)	36 ¹ / ₈ " (918mm)	15" (381mm)	XXX-304F-36-B
	36" (914mm)	38 ¹ / ₄ " (972mm)	15 ⁷ / ₈ " (403mm)	XXX-364F-36-B

CSA CERTIFIED FOR CSA SYSTEMS

Radius - R	Width - W	"A" Dimension	"B" Dimension	Part Number
12" (305mm)	6" (152mm)	7 ¹ / ₂ " (191mm)	2" (51mm)	XXX-063F-12-B
	9" (229mm)	8 ¹ / ₄ " (210mm)	2 ¹ / ₄ " (57mm)	XXX-093F-12-B
	12" (305mm)	9" (229mm)	2 ⁵ / ₈ " (60mm)	XXX-123F-12-B
	18" (457mm)	10 ¹ / ₂ " (267mm)	2 ¹ / ₈ " (73mm)	XXX-183F-12-B
	24" (610mm)	12" (305mm)	3 ¹ / ₄ " (83mm)	XXX-243F-12-B
	30" (762mm)	13 ¹ / ₂ " (343mm)	3 ⁵ / ₈ " (92mm)	XXX-303F-12-B
	36" (914mm)	15" (381mm)	4" (102mm)	XXX-363F-12-B
24" (610mm)	6" (152mm)	13 ¹ / ₂ " (343mm)	3 ⁵ / ₈ " (92mm)	XXX-063F-24-B
	9" (229mm)	14 ¹ / ₄ " (362mm)	3 ³ / ₈ " (98mm)	XXX-093F-24-B
	12" (305mm)	15" (381mm)	4" (102mm)	XXX-123F-24-B
	18" (457mm)	16 ¹ / ₂ " (419mm)	4 ¹ / ₈ " (111mm)	XXX-183F-24-B
	24" (610mm)	18" (457mm)	4 ¹ / ₈ " (124mm)	XXX-243F-24-B
	30" (762mm)	19 ¹ / ₂ " (495mm)	5 ¹ / ₄ " (133mm)	XXX-303F-24-B
	36" (914mm)	21" (533mm)	5 ⁵ / ₈ " (143mm)	XXX-363F-24-B
36" (914mm)	6" (152mm)	19 ¹ / ₂ " (495mm)	5 ¹ / ₄ " (133mm)	XXX-063F-36-B
	9" (229mm)	20 ¹ / ₄ " (514mm)	5 ¹ / ₂ " (140mm)	XXX-093F-36-B
	12" (305mm)	21" (533mm)	5 ⁵ / ₈ " (143mm)	XXX-123F-36-B
	18" (457mm)	22 ¹ / ₂ " (572mm)	6" (152mm)	XXX-183F-36-B
	24" (610mm)	24" (610mm)	6 ¹ / ₂ " (165mm)	XXX-243F-36-B
	30" (762mm)	25 ¹ / ₂ " (648mm)	6 ³ / ₈ " (175mm)	XXX-303F-36-B
	36" (914mm)	27" (686mm)	7 ¹ / ₄ " (184mm)	XXX-363F-36-B

*Add suffix -V (vented) or -S (solid) to catalog number.

Example: 234-124F-12-V

Note: When small or in-between angles are needed, use Cope's Adjustable Connectors.

*Add suffix -V (vented) or -S (solid) to catalog number.

Example: 234-123F-12-V

HORIZONTAL TEE [FT]

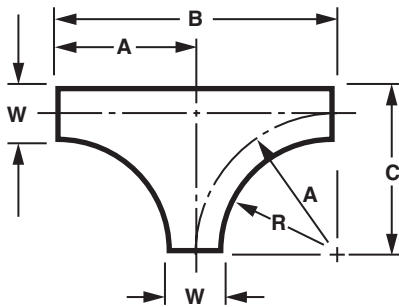
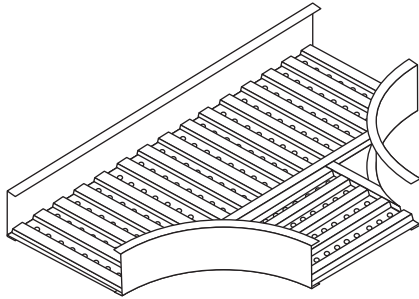

CSA CERTIFIED FOR CSA SYSTEMS

Radius - R	Width - W	"A" Dimension		"B" Dimension		"C" Dimension		Part Number
12" (305mm)	6" (152mm)	15"	(381mm)	30"	(762mm)	18"	(457mm)	XXX-06FT-12-B
	9" (229mm)	16½"	(419mm)	33"	(838mm)	21"	(533mm)	XXX-09FT-12-B
	12" (305mm)	18"	(457mm)	36"	(914mm)	24"	(610mm)	XXX-12FT-12-B
	18" (457mm)	21"	(533mm)	42"	(1067mm)	30"	(762mm)	XXX-18FT-12-B
	24" (610mm)	24"	(610mm)	48"	(1219mm)	36"	(914mm)	XXX-24FT-12-B
	30" (762mm)	27"	(686mm)	54"	(1372mm)	42"	(1067mm)	XXX-30FT-12-B
24" (610mm)	36" (914mm)	30"	(762mm)	60"	(1524mm)	48"	(1219mm)	XXX-36FT-12-B
	6" (152mm)	27"	(686mm)	54"	(1372mm)	30"	(762mm)	XXX-06FT-24-B
	9" (229mm)	28½"	(724mm)	57"	(1448mm)	33"	(838mm)	XXX-09FT-24-B
	12" (305mm)	30"	(762mm)	60"	(1524mm)	36"	(914mm)	XXX-12FT-24-B
	18" (457mm)	33"	(838mm)	66"	(1676mm)	42"	(1067mm)	XXX-18FT-24-B
	24" (610mm)	36"	(914mm)	72"	(1829mm)	48"	(1219mm)	XXX-24FT-24-B
36" (914mm)	30" (762mm)	39"	(991mm)	78"	(1981mm)	54"	(1372mm)	XXX-30FT-24-B
	36" (914mm)	42"	(1067mm)	84"	(2134mm)	60"	(1524mm)	XXX-36FT-24-B
	6" (152mm)	39"	(991mm)	78"	(1981mm)	42"	(1067mm)	XXX-06FT-36-B
	9" (229mm)	40½"	(1029mm)	81"	(2057mm)	45"	(1143mm)	XXX-09FT-36-B
	12" (305mm)	42"	(1067mm)	84"	(2134mm)	48"	(1219mm)	XXX-12FT-36-B
	18" (457mm)	45"	(1143mm)	90"	(2286mm)	54"	(1372mm)	XXX-18FT-36-B
36" (914mm)	24" (610mm)	48"	(1219mm)	96"	(2438mm)	60"	(1524mm)	XXX-24FT-36-B
	30" (762mm)	51"	(1295mm)	102"	(2591mm)	66"	(1676mm)	XXX-30FT-36-B
	36" (914mm)	54"	(1372mm)	108"	(2743mm)	72"	(1829mm)	XXX-36FT-36-B

* Add suffix -V (vented) or -S (solid) to catalog number. - Example: 234-12FT-12-V

HORIZONTAL CROSS [FC]

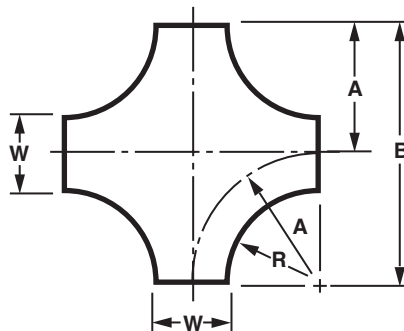
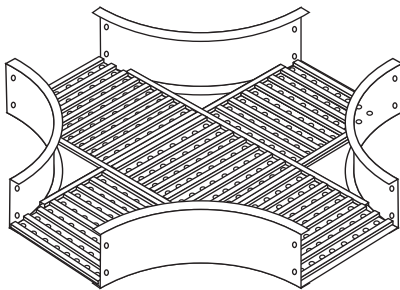

CSA CERTIFIED FOR CSA SYSTEMS

Radius - R	Width - W	"A" Dimension		"B" Dimension		Part Number
12" (305mm)	6" (152mm)	15"	(381mm)	30"	(762mm)	XXX-06FC-12-B
	9" (229mm)	16½"	(419mm)	33"	(838mm)	XXX-09FC-12-B
	12" (305mm)	18"	(457mm)	36"	(914mm)	XXX-12FC-12-B
	18" (457mm)	21"	(533mm)	42"	(1067mm)	XXX-18FC-12-B
	24" (610mm)	24"	(610mm)	48"	(1219mm)	XXX-24FC-12-B
	30" (762mm)	27"	(686mm)	54"	(1372mm)	XXX-30FC-12-B
24" (610mm)	36" (914mm)	30"	(762mm)	60"	(1524mm)	XXX-36FC-12-B
	6" (152mm)	27"	(686mm)	54"	(1372mm)	XXX-06FC-24-B
	9" (229mm)	28½"	(724mm)	57"	(1448mm)	XXX-09FC-24-B
	12" (305mm)	30"	(762mm)	60"	(1524mm)	XXX-12FC-24-B
	18" (457mm)	33"	(838mm)	66"	(1676mm)	XXX-18FC-24-B
	24" (610mm)	36"	(914mm)	72"	(1829mm)	XXX-24FC-24-B
36" (914mm)	30" (762mm)	39"	(991mm)	78"	(1981mm)	XXX-30FC-24-B
	36" (914mm)	42"	(1067mm)	84"	(2134mm)	XXX-36FC-24-B
	6" (152mm)	39"	(991mm)	78"	(1981mm)	XXX-06FC-36-B
	9" (229mm)	40½"	(1029mm)	81"	(2057mm)	XXX-09FC-36-B
	12" (305mm)	42"	(1067mm)	84"	(2134mm)	XXX-12FC-36-B
	18" (457mm)	45"	(1143mm)	90"	(2286mm)	XXX-18FC-36-B
36" (914mm)	24" (610mm)	48"	(1219mm)	96"	(2438mm)	XXX-24FC-36-B
	30" (762mm)	51"	(1295mm)	102"	(2591mm)	XXX-30FC-36-B
	36" (914mm)	54"	(1372mm)	108"	(2743mm)	XXX-36FC-36-B

*Add suffix -V (vented) or -S (solid) to catalog number.

Example: 234-12FC-12-V

Note: Nominal 9" rung spacing maintained through centerline of all fittings.

TROF CABLE TRAY SYSTEM

HORIZONTAL TAPPED TEE [TT]

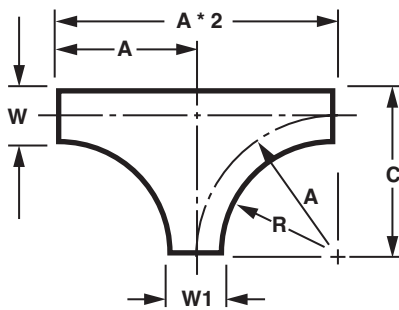
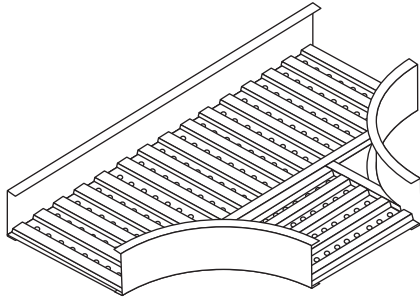

CSA CERTIFIED FOR CSA SYSTEMS

R Radius	W Width	W1 Width	"A" Dimension	"C" Dimension	Part Number	
12" (305mm)	36" (914mm)	30" (762mm)	27" (686mm)	48" (1219mm)	XXX-36TT-30-12-B	
		24" (610mm)	24" (610mm)		XXX-36TT-24-12-B	
		18" (457mm)	21" (533mm)		XXX-36TT-18-12-B	
		12" (305mm)	18" (457mm)		XXX-36TT-12-12-B	
		9" (229mm)	16½" (419mm)		XXX-36TT-09-12-B	
		6" (152mm)	15" (381mm)		XXX-36TT-06-12-B	
	30" (762mm)	24" (610mm)	24" (610mm)	42" (1067mm)	XXX-30TT-24-12-B	
		18" (457mm)	21" (533mm)		XXX-30TT-18-12-B	
		12" (305mm)	18" (457mm)		XXX-30TT-12-12-B	
		9" (229mm)	16½" (419mm)		XXX-30TT-09-12-B	
		6" (152mm)	15" (381mm)		XXX-30TT-06-12-B	
		24" (610mm)	18" (457mm)		21" (533mm)	36" (914mm)
12" (305mm)	18" (457mm)		XXX-24TT-12-12-B			
9" (229mm)	16½" (419mm)		XXX-24TT-09-12-B			
6" (152mm)	15" (381mm)		XXX-24TT-06-12-B			
18" (457mm)	12" (305mm)		18" (457mm)	30" (762mm)	XXX-18TT-12-12-B	
	9" (229mm)		16½" (419mm)		XXX-18TT-09-12-B	
	6" (152mm)	15" (381mm)	XXX-18TT-06-12-B			
12" (305mm)	9" (229mm)	16½" (419mm)	24" (610mm)	XXX-12TT-09-12-B		
	6" (152mm)	15" (381mm)		XXX-12TT-06-12-B		
9" (229mm)	6" (152mm)	15" (381mm)	21" (533mm)	XXX-09TT-06-12-B		

HORIZONTAL TAPPED TEE [TT] (CONT.)

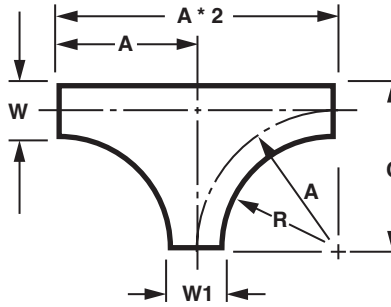

CSA CERTIFIED FOR CSA SYSTEMS

R Radius	W Width	W1 Width	"A" Dimension	"C" Dimension	Part Number		
24" (610mm)	36" (914mm)	30" (762mm)	39" (991mm)	60" (1524mm)	XXX-36TT-30-24-B		
		24" (610mm)	36" (914mm)		XXX-36TT-24-24-B		
		18" (457mm)	33" (838mm)		XXX-36TT-18-24-B		
		12" (305mm)	30" (762mm)		XXX-36TT-12-24-B		
		9" (229mm)	28½" (724mm)		XXX-36TT-09-24-B		
		6" (152mm)	27" (686mm)		XXX-36TT-06-24-B		
	30" (762mm)	24" (610mm)	36" (914mm)	54" (1372mm)	XXX-30TT-24-24-B		
		18" (457mm)	33" (838mm)		XXX-30TT-18-24-B		
		12" (305mm)	30" (762mm)		XXX-30TT-12-24-B		
		9" (229mm)	28½" (724mm)		XXX-30TT-09-24-B		
		6" (152mm)	27" (686mm)		XXX-30TT-06-24-B		
		24" (610mm)	18" (457mm)		33" (838mm)	48" (1219mm)	XXX-24TT-18-24-B
	12" (305mm)		30" (762mm)	XXX-24TT-12-24-B			
	9" (229mm)		28½" (724mm)	XXX-24TT-09-24-B			
	6" (152mm)		27" (686mm)	XXX-24TT-06-24-B			
	18" (457mm)		12" (305mm)	30" (762mm)	42" (1067mm)		XXX-18TT-12-24-B
			9" (229mm)	28½" (724mm)			XXX-18TT-09-24-B
		6" (152mm)	27" (686mm)	XXX-18TT-06-24-B			
	12" (305mm)	9" (229mm)	28½" (724mm)	36" (914mm)	XXX-12TT-09-24-B		
		6" (152mm)	27" (686mm)		XXX-12TT-06-24-B		
		9" (229mm)	27" (686mm)		XXX-09TT-06-24-B		

CSA CERTIFIED FOR CSA SYSTEMS

R Radius	W Width	W1 Width	"A" Dimension	"C" Dimension	Part Number		
36" (914mm)	36" (914mm)	30" (762mm)	51" (1295mm)	72" (1829mm)	XXX-36TT-30-36-B		
		24" (610mm)	48" (1219mm)		XXX-36TT-24-36-B		
		18" (457mm)	45" (1143mm)		XXX-36TT-18-36-B		
		12" (305mm)	42" (1067mm)		XXX-36TT-12-36-B		
		9" (229mm)	40½" (1029mm)		XXX-36TT-09-36-B		
		6" (152mm)	39" (991mm)		XXX-36TT-06-36-B		
	30" (762mm)	24" (610mm)	48" (1219mm)	66" (1676mm)	XXX-30TT-24-36-B		
		18" (457mm)	45" (1143mm)		XXX-30TT-18-36-B		
		12" (305mm)	42" (1067mm)		XXX-30TT-12-36-B		
		9" (229mm)	40½" (1029mm)		XXX-30TT-09-36-B		
		6" (152mm)	39" (991mm)		XXX-30TT-06-36-B		
		24" (610mm)	18" (457mm)		45" (1143mm)	60" (1524mm)	XXX-24TT-18-36-B
	12" (305mm)		42" (1067mm)	XXX-24TT-12-36-B			
	9" (229mm)		40½" (1029mm)	XXX-24TT-09-36-B			
	6" (152mm)		39" (991mm)	XXX-24TT-06-36-B			
	18" (457mm)		12" (305mm)	v (1067mm)	54" (1372mm)		XXX-18TT-12-36-B
			9" (229mm)	40½" (1029mm)			XXX-18TT-09-36-B
		6" (152mm)	39" (991mm)	XXX-18TT-06-36-B			
	12" (305mm)	9" (229mm)	40½" (1029mm)	48" (1219mm)	XXX-12TT-09-36-B		
		6" (152mm)	39" (991mm)		XXX-12TT-06-36-B		
		9" (229mm)	39" (991mm)		XXX-09TT-06-36-B		

Note: Nominal 9" rung spacing maintained through centerline of all fittings.

TROF CABLE TRAY SYSTEM

HORIZONTAL TAPPED CROSS [TC]

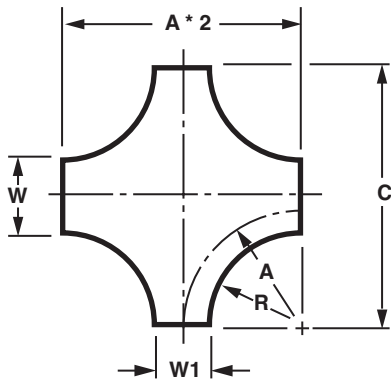
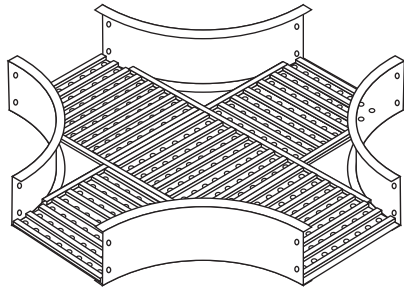

CSA CERTIFIED FOR CSA SYSTEMS

R Radius	W Width	W1 Width	"A" Dimension	"C" Dimension	Part Number
36" (914mm)		30" (762mm)	27" (686mm)	60" (1524mm)	XXX-36TC-30-12-B
		24" (610mm)	24" (610mm)		XXX-36TC-24-12-B
		18" (457mm)	21" (533mm)		XXX-36TC-18-12-B
		12" (305mm)	18" (457mm)		XXX-36TC-12-12-B
		9" (229mm)	16½" (419mm)		XXX-36TC-09-12-B
		6" (152mm)	15" (381mm)		XXX-36TC-06-12-B
30" (762mm)		24" (610mm)	24" (610mm)	54" (1372mm)	XXX-30TC-24-12-B
		18" (457mm)	21" (533mm)		XXX-30TC-18-12-B
		12" (305mm)	18" (457mm)		XXX-30TC-12-12-B
		9" (229mm)	16½" (419mm)		XXX-30TC-09-12-B
12" (305mm)		6" (152mm)	15" (381mm)		XXX-30TC-06-12-B
		18" (457mm)	21" (533mm)		XXX-24TC-18-12-B
		12" (305mm)	18" (457mm)		XXX-24TC-12-12-B
		9" (229mm)	16½" (419mm)		XXX-24TC-09-12-B
18" (457mm)		6" (152mm)	15" (381mm)	48" (1219mm)	XXX-24TC-06-12-B
		12" (305mm)	18" (457mm)		XXX-18TC-12-12-B
		9" (229mm)	16½" (419mm)		XXX-18TC-09-12-B
12" (305mm)		6" (152mm)	15" (381mm)	42" (1067mm)	XXX-18TC-06-12-B
		9" (229mm)	16½" (419mm)		XXX-12TC-09-12-B
		6" (152mm)	15" (381mm)		XXX-12TC-06-12-B
9" (229mm)		6" (152mm)	15" (381mm)	36" (914mm)	XXX-09TC-06-12-B
				33" (838mm)	XXX-09TC-06-12-B

HORIZONTAL TAPPED CROSS [TC] (CONT.)

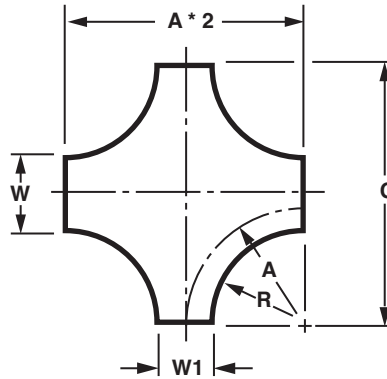

CSA CERTIFIED FOR CSA SYSTEMS

R Radius	W Width	W1 Width	"A" Dimension	"C" Dimension	Part Number		
24" (610mm)	36" (914mm)	30" (762mm)	39" (991mm)	84" (2134mm)	XXX-36TC-30-24-B		
		24" (610mm)	36" (914mm)		XXX-36TC-24-24-B		
		18" (457mm)	33" (838mm)		XXX-36TC-18-24-B		
		12" (305mm)	30" (762mm)		XXX-36TC-12-24-B		
		9" (229mm)	28½" (724mm)		XXX-36TC-09-24-B		
		6" (152mm)	27" (686mm)		XXX-36TC-06-24-B		
	30" (762mm)	24" (610mm)	36" (914mm)	78" (1981mm)	XXX-30TC-24-24-B		
		18" (457mm)	33" (838mm)		XXX-30TC-18-24-B		
		12" (305mm)	30" (762mm)		XXX-30TC-12-24-B		
		9" (229mm)	28½" (724mm)		XXX-30TC-09-24-B		
		6" (152mm)	27" (686mm)		XXX-30TC-06-24-B		
		24" (610mm)	18" (457mm)		33" (838mm)	72" (1829mm)	XXX-24TC-18-24-B
	12" (305mm)		30" (762mm)	XXX-24TC-12-24-B			
	9" (229mm)		28½" (724mm)	XXX-24TC-09-24-B			
	6" (152mm)		27" (686mm)	XXX-24TC-06-24-B			
	18" (457mm)		12" (305mm)	30" (762mm)	66" (1676mm)		XXX-18TC-12-24-B
			9" (229mm)	28½" (724mm)			XXX-18TC-09-24-B
		6" (152mm)	27" (686mm)	XXX-18TC-06-24-B			
	12" (305mm)	9" (229mm)	28½" (724mm)	60" (1524mm)	XXX-12TC-09-24-B		
		6" (152mm)	27" (686mm)		XXX-12TC-06-24-B		
	9" (229mm)	6" (152mm)	27" (686mm)	57" (1448mm)	XXX-09TC-06-24-B		

CSA CERTIFIED FOR CSA SYSTEMS

R Radius	W Width	W1 Width	"A" Dimension	"C" Dimension	Part Number		
36" (914mm)	36" (914mm)	30" (762mm)	51" (1295mm)	108" (2743mm)	XXX-36TC-30-36-B		
		24" (610mm)	48" (1219mm)		XXX-36TC-24-36-B		
		18" (457mm)	45" (1143mm)		XXX-36TC-18-36-B		
		12" (305mm)	42" (1067mm)		XXX-36TC-12-36-B		
		9" (229mm)	40½" (1029mm)		XXX-36TC-09-36-B		
		6" (152mm)	39" (991mm)		XXX-36TC-06-36-B		
	30" (762mm)	24" (610mm)	48" (1219mm)	102" (2591mm)	XXX-30TC-24-36-B		
		18" (457mm)	45" (1143mm)		XXX-30TC-18-36-B		
		12" (305mm)	42" (1067mm)		XXX-30TC-12-36-B		
		9" (229mm)	40½" (1029mm)		XXX-30TC-09-36-B		
		6" (152mm)	39" (991mm)		XXX-30TC-06-36-B		
		24" (610mm)	18" (457mm)		45" (1143mm)	96" (2438mm)	XXX-24TC-18-36-B
	12" (305mm)		42" (1067mm)	XXX-24TC-12-36-B			
	9" (229mm)		40½" (1029mm)	XXX-24TC-09-36-B			
	6" (152mm)		39" (991mm)	XXX-24TC-06-36-B			
	18" (457mm)		12" (305mm)	42" (1067mm)	90" (2286mm)		XXX-18TC-12-36-B
			9" (229mm)	40½" (1029mm)			XXX-18TC-09-36-B
		6" (152mm)	39" (991mm)	XXX-18TC-06-36-B			
	12" (305mm)	9" (229mm)	40½" (1029mm)	84" (2134mm)	XXX-12TC-09-36-B		
		6" (152mm)	39" (991mm)		XXX-12TC-06-36-B		
	9" (229mm)	6" (152mm)	39" (991mm)	81" (2057mm)	XXX-09TC-06-36-B		

TROF CABLE TRAY SYSTEM

STRAIGHT REDUCER [ST]

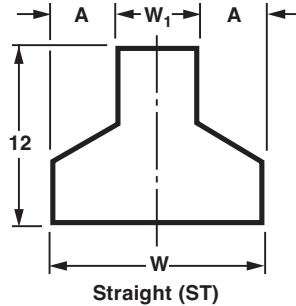
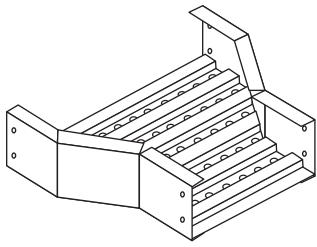

CSA CERTIFIED FOR CSA SYSTEMS

Width - W	Width - W1	"A" Dimension	Part Number
36" (914mm)	30" (762mm)	3" (76mm)	XXX-36ST-30-B
	24" (610mm)	6" (152mm)	XXX-36ST-24-B
	18" (457mm)	9" (229mm)	XXX-36ST-18-B
	12" (305mm)	12" (305mm)	XXX-36ST-12-B
	9" (229mm)	13½" (343mm)	XXX-36ST-09-B
	6" (152mm)	15" (381mm)	XXX-36ST-06-B
30" (762mm)	24" (610mm)	3" (76mm)	XXX-30ST-24-B
	18" (457mm)	6" (152mm)	XXX-30ST-18-B
	12" (305mm)	9" (229mm)	XXX-30ST-12-B
	9" (229mm)	10½" (267mm)	XXX-30ST-09-B
	6" (152mm)	12" (304mm)	XXX-30ST-06-B
24" (610mm)	18" (457mm)	3" (76mm)	XXX-24ST-18-B
	12" (305mm)	6" (152mm)	XXX-24ST-12-B
	9" (229mm)	7½" (191mm)	XXX-24ST-09-B
	6" (152mm)	9" (229mm)	XXX-24ST-06-B
18" (457mm)	12" (305mm)	3" (76mm)	XXX-18ST-12-B
	9" (229mm)	4½" (114mm)	XXX-18ST-09-B
	6" (152mm)	6" (152mm)	XXX-18ST-06-B
12" (305mm)	9" (229mm)	1½" (38mm)	XXX-12ST-09-B
	6" (152mm)	3" (76mm)	XXX-12ST-06-B
9" (229mm)	6" (152mm)	1½" (38mm)	XXX-09ST-06-B

*Add suffix -V (vented) or -S (solid) to catalog number.

Example: 234-36ST-12-V

Left Hand [LH] & Right Hand [RH] Reducer

LEFT HAND [LH] & RIGHT HAND [RH] REDUCER

LEFT HAND (LH)

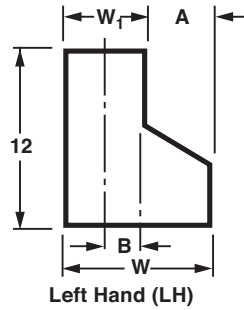
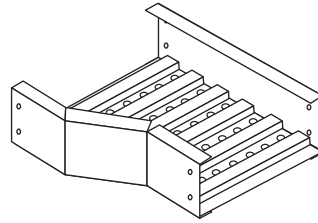

RIGHT HAND (RH)

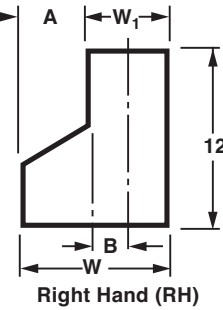
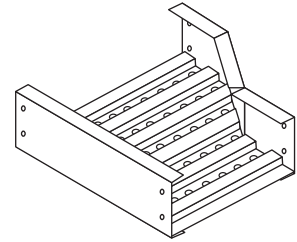

CSA CERTIFIED FOR CSA SYSTEMS

Width - W	"W1" Dim.	"A" Dim.	"B" Dim.	Part Number
36" (914mm)	30" (914mm)	6" (152mm)	15" (381mm)	XXX-36(LH/RH)-30-B
	24" (610mm)	12" (305mm)	12" (305mm)	XXX-36(LH/RH)-24-B
	18" (457mm)	18" (457mm)	9" (229mm)	XXX-36(LH/RH)-18-B
	12" (305mm)	24" (610mm)	6" (152mm)	XXX-36(LH/RH)-12-B
	9" (229mm)	27" (686mm)	4½" (114mm)	XXX-36(LH/RH)-09-B
	6" (152mm)	30" (762mm)	3" (76mm)	XXX-36(LH/RH)-06-B
30" (762mm)	24" (610mm)	6" (152mm)	12" (305mm)	XXX-30(LH/RH)-24-B
	18" (457mm)	12" (305mm)	9" (229mm)	XXX-30(LH/RH)-18-B
	12" (305mm)	18" (457mm)	6" (152mm)	XXX-30(LH/RH)-12-B
	9" (229mm)	21" (533mm)	4½" (114mm)	XXX-30(LH/RH)-09-B
	6" (152mm)	24" (610mm)	3" (76mm)	XXX-30(LH/RH)-06-B
24" (610mm)	18" (457mm)	6" (152mm)	9" (229mm)	XXX-24(LH/RH)-18-B
	12" (305mm)	12" (305mm)	6" (152mm)	XXX-24(LH/RH)-12-B
	9" (229mm)	15" (381mm)	4½" (114mm)	XXX-24(LH/RH)-09-B
	6" (152mm)	18" (457mm)	3" (76mm)	XXX-24(LH/RH)-06-B
18" (457mm)	12" (305mm)	6" (152mm)	6" (152mm)	XXX-18(LH/RH)-12-B
	9" (229mm)	9" (229mm)	4½" (114mm)	XXX-18(LH/RH)-09-B
	6" (152mm)	12" (305mm)	3" (76mm)	XXX-18(LH/RH)-06-B
12" (305mm)	9" (229mm)	3" (76mm)	4½" (114mm)	XXX-12(LH/RH)-09-B
	6" (152mm)	6" (152mm)	3" (76mm)	XXX-12(LH/RH)-06-B
9" (229mm)	6" (152mm)	3" (76mm)	3" (76mm)	XXX-09(LH/RH)-06-B

*Add suffix -V (vented) or -S (solid) to catalog number.

Example: 234-36LH-12-V

Note: COPE FITTINGS are offered in 12", 24", and 36" radius.

When small or in-between angles are needed, use Cope's Adjustable Connectors.

ADJUSTABLE ELBOW [AF]

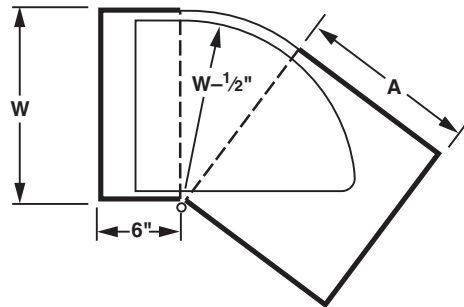
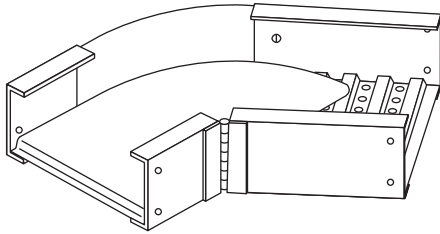

CSA CERTIFIED FOR CSA SYSTEMS

Width - W	"A" Dimension	Part Number
6" (152mm)	8" (203mm)	XXX-06AF-B
9" (229mm)	11" (279mm)	XXX-09AF-B
12" (305mm)	14" (356mm)	XXX-12AF-B
18" (457mm)	20" (508mm)	XXX-18AF-B
24" (610mm)	26" (660mm)	XXX-24AF-B
30" (762mm)	32" (813mm)	XXX-30AF-B
36" (914mm)	38" (965mm)	XXX-36AF-B

Both rails at hinge break to be bonded if fitting is used as equipment grounding conductor. * Add suffix -V (vented) or -S (solid) to catalog number. Example: 234-12AF-V

45° "Y" BRANCH LEFT [LY] & RIGHT [RY]

RIGHT HAND [RY]
SHOWN

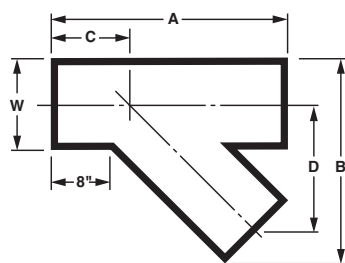
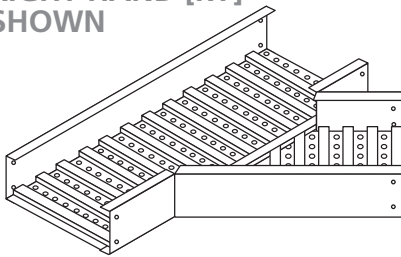

CSA CERTIFIED FOR CSA SYSTEMS

Width - W	"A" Dim.	"B" Dim.	"C" Dim.	"D" Dim.	Part Number
6" (152mm)	22½" (571mm)	16¼" (413mm)	11⅜" (289mm)	11⅞" (283mm)	XXX-06(LY/Ry)-B
9" (229mm)	26¾" (679mm)	21⅝" (543mm)	13" (330mm)	13¾" (349mm)	XXX-09(LY/Ry)-B
12" (305mm)	31" (787mm)	26½" (673mm)	14¾" (375mm)	16¼" (412mm)	XXX-12(LY/Ry)-B
18" (457mm)	39½" (1003mm)	36¾" (933mm)	18⅞" (460mm)	21⅝" (543mm)	XXX-18(LY/Ry)-B
24" (610mm)	48" (1219mm)	47" (1193mm)	21½" (546mm)	26½" (673mm)	XXX-24(LY/Ry)-B
30" (762mm)	56⅝" (1432mm)	57¼" (1454mm)	24¾" (629mm)	31⅞" (803mm)	XXX-30(LY/Ry)-B
36" (914mm)	65" (1651mm)	67½" (1714mm)	28¼" (718mm)	36¾" (933mm)	XXX-36(LY/Ry)-B

*Add suffix -V (vented) or -S (solid) to catalog number.
Example: 234-12RY-V

TROF CABLE TRAY SYSTEM

90° VERTICAL ELBOW OUTSIDE [90] & INSIDE [9I]

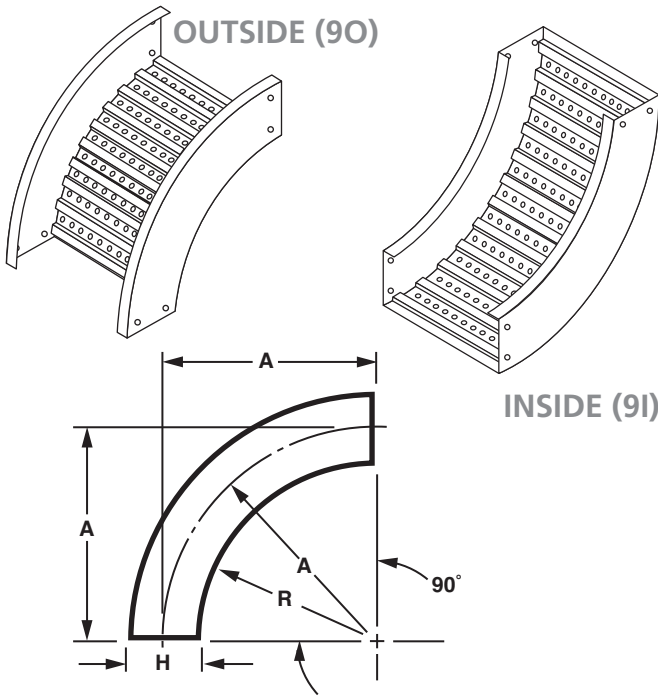

CSA CERTIFIED FOR CSA SYSTEMS

Radius - R	"H" Dim.	"A" Dim.	Part Number
12" (305mm)	3½" (89mm)	13¾" (349mm)	X3X-WW(90/9I)-12-B
	4¼" (108mm)	14⅞" (359mm)	X4X-WW(90/9I)-12-B
	5¼" (133mm)	14⅝" (372mm)	X5X-WW(90/9I)-12-B
	6¼" (159mm)	15⅞" (384mm)	X6X-WW(90/9I)-12-B
24" (610mm)	3½" (89mm)	25¾" (654mm)	X3X-WW(90/9I)-24-B
	4¼" (108mm)	26⅞" (664mm)	X4X-WW(90/9I)-24-B
	5¼" (133mm)	26⅝" (676mm)	X5X-WW(90/9I)-24-B
36" (914mm)	6¼" (159mm)	27⅞" (689mm)	X6X-WW(90/9I)-24-B
	3½" (89mm)	37¾" (959mm)	X3X-WW(90/9I)-36-B
	4¼" (108mm)	36⅞" (969mm)	X4X-WW(90/9I)-36-B
	5¼" (133mm)	36⅝" (981mm)	X5X-WW(90/9I)-36-B
6¼" (159mm)	39⅞" (994mm)	X6X-WW(90/9I)-36-B	

*Add suffix -V (vented) or -S (solid) to catalog number.
Example: 234-129O-12-V

60° VERTICAL ELBOW OUTSIDE [60] & INSIDE [6I]

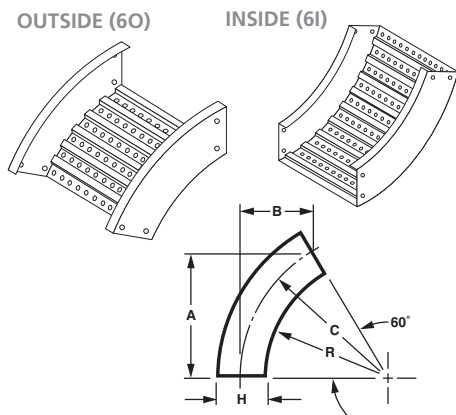

CSA CERTIFIED FOR CSA SYSTEMS

Radius - R	"H" Dim.	"A" Dim.	"B" Dim.	"C" Dim.	Part Number
12" (305mm)	3½" (89mm)	11⅞" (302mm)	6⅞" (175mm)	13¾" (349mm)	X3X-WW(60/6I)-12-B
	4¼" (108mm)	12¼" (311mm)	7⅞" (181mm)	14⅞" (359mm)	X4X-WW(60/6I)-12-B
	5¼" (133mm)	12⅝" (321mm)	7⅞" (187mm)	14⅝" (372mm)	X5X-WW(60/6I)-12-B
	6¼" (159mm)	13⅞" (334mm)	7⅞" (194mm)	15⅞" (384mm)	X6X-WW(60/6I)-12-B
24" (610mm)	3½" (89mm)	22¼" (565mm)	12⅞" (327mm)	25¾" (654mm)	X3X-WW(60/6I)-24-B
	4¼" (108mm)	22⅝" (575mm)	13⅞" (334mm)	26⅞" (664mm)	X4X-WW(60/6I)-24-B
	5¼" (133mm)	23⅞" (588mm)	13⅞" (340mm)	26⅝" (676mm)	X5X-WW(60/6I)-24-B
	6¼" (159mm)	23½" (597mm)	13" (330mm)	27⅞" (689mm)	X6X-WW(60/6I)-24-B
36" (914mm)	3½" (89mm)	32¾" (832mm)	18⅞" (480mm)	37¾" (959mm)	X3X-WW(60/6I)-36-B
	4¼" (108mm)	33" (838mm)	19⅞" (486mm)	38⅞" (969mm)	X4X-WW(60/6I)-36-B
	5¼" (133mm)	33½" (851mm)	19⅞" (492mm)	38⅝" (981mm)	X5X-WW(60/6I)-36-B
	6¼" (159mm)	33⅞" (861mm)	19⅞" (499mm)	39⅞" (994mm)	X6X-WW(60/6I)-36-B

*Add suffix -V (vented) or -S (solid) to catalog number.

Example: 234-126O-12-V 90° Vertical Elbow Outside [90] & Inside [9I]

45° VERTICAL ELBOW OUTSIDE [40] & INSIDE [4I]

OUTSIDE (40)

INSIDE (4I)

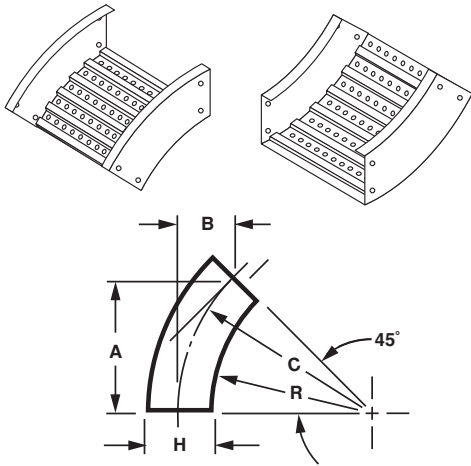

CSA CERTIFIED FOR CSA SYSTEMS

Radius - R	"H" Dim.	"A" Dim.	"B" Dim.	"C" Dim.	Part Number
12" (305mm)	3½" (89mm)	9¾" (248mm)	4" (102mm)	13¾" (349mm)	X3X-WW(40/4I)-12-B
	4¼" (108mm)	10" (254mm)	4½" (105mm)	14½" (359mm)	X4X-WW(40/4I)-12-B
	5¼" (133mm)	10⅝" (264mm)	4¾" (108mm)	14⅝" (372mm)	X5X-WW(40/4I)-12-B
	6¼" (159mm)	10¾" (273mm)	4½" (114mm)	15½" (384mm)	X6X-WW(40/4I)-12-B
24" (610mm)	3½" (89mm)	18¼" (464mm)	7½" (191mm)	25¾" (654mm)	X3X-WW(40/4I)-24-B
	4¼" (108mm)	18½" (470mm)	7⅝" (194mm)	26⅝" (664mm)	X4X-WW(40/4I)-24-B
	5¼" (133mm)	18⅞" (480mm)	7⅞" (200mm)	26⅞" (676mm)	X5X-WW(40/4I)-24-B
	6¼" (159mm)	19¼" (489mm)	8" (203mm)	27⅞" (689mm)	X6X-WW(40/4I)-24-B
36" (914mm)	3½" (89mm)	26¾" (679mm)	11⅞" (283mm)	37¾" (959mm)	X3X-WW(40/4I)-36-B
	4¼" (108mm)	27" (686mm)	11⅞" (283mm)	38⅞" (969mm)	X4X-WW(40/4I)-36-B
	5¼" (133mm)	27⅝" (695mm)	11⅞" (289mm)	38⅞" (981mm)	X5X-WW(40/4I)-36-B
	6¼" (159mm)	27⅞" (702mm)	11½" (292mm)	39⅞" (994mm)	X6X-WW(40/4I)-36-B

*Add suffix -V (vented) or -S (solid) to catalog number.

Example: 234-124I-12-V

30° VERTICAL ELBOW OUTSIDE [30] & INSIDE [3I]

OUTSIDE (30)

INSIDE (3I)

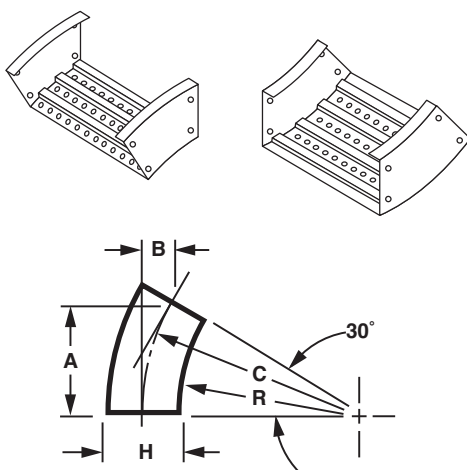

CSA CERTIFIED FOR CSA SYSTEMS

Radius - R	"H" Dim.	"A" Dim.	"B" Dim.	"C" Dim.	Part Number
12" (305mm)	3½" (89mm)	6⅞" (175mm)	1⅞" (48mm)	13¾" (349mm)	X3X-WW(30/3I)-12-B
	4¼" (108mm)	7⅞" (181mm)	1⅞" (48mm)	14½" (359mm)	X4X-WW(30/3I)-12-B
	5¼" (133mm)	7⅞" (187mm)	2" (51mm)	14⅝" (372mm)	X5X-WW(30/3I)-12-B
	6¼" (159mm)	7⅞" (194mm)	2" (51mm)	15½" (384mm)	X6X-WW(30/3I)-12-B
24" (610mm)	3½" (89mm)	12⅞" (327mm)	3½" (89mm)	25¾" (654mm)	X3X-WW(30/3I)-24-B
	4¼" (108mm)	13⅞" (334mm)	3½" (89mm)	26⅞" (664mm)	X4X-WW(30/3I)-24-B
	5¼" (133mm)	13⅞" (340mm)	3⅞" (92mm)	26⅞" (676mm)	X5X-WW(30/3I)-24-B
	6¼" (159mm)	13⅞" (346mm)	3⅞" (92mm)	27⅞" (689mm)	X6X-WW(30/3I)-24-B
36" (914mm)	3½" (89mm)	18⅞" (480mm)	5⅞" (130mm)	37¾" (959mm)	X3X-WW(30/3I)-36-B
	4¼" (108mm)	19⅞" (486mm)	5⅞" (130mm)	38⅞" (969mm)	X4X-WW(30/3I)-36-B
	5¼" (133mm)	19⅞" (492mm)	5¼" (133mm)	38⅞" (981mm)	X5X-WW(30/3I)-36-B
	6¼" (159mm)	19⅞" (499mm)	5¼" (133mm)	39⅞" (994mm)	X6X-WW(30/3I)-36-B

*Add suffix -V (vented) or -S (solid) to catalog number.

Example: 234-123I-12-V

TROF CABLE TRAY SYSTEM

VERTICAL TEE DOWN [VT] & UP [OT]

*J" hooks not included.
Order separately (Cat. No. 75170).

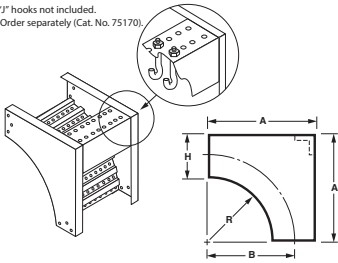

CSA CERTIFIED FOR CSA SYSTEMS

Radius-R	"H" Dim.	"A" Dimension	"B" Dimension	"C" Dimension	Part Number
12" (305mm)	3½" (89mm)	27½" (699mm)	15½" (394mm)	13¾" (349mm)	X3X-WW(VT/OT)-12-B
	4¼" (108mm)	28¼" (718mm)	16¼" (413mm)	14⅞" (359mm)	X4X-WW(VT/OT)-12-B
	5¼" (133mm)	29¼" (743mm)	17¼" (438mm)	14⅝" (371mm)	X5X-WW(VT/OT)-12-B
	6¼" (159mm)	30¼" (768mm)	18¼" (464mm)	15⅞" (384mm)	X6X-WW(VT/OT)-12-B
24" (610mm)	3½" (89mm)	51½" (1308mm)	27½" (699mm)	25¾" (654mm)	X3X-WW(VT/OT)-24-B
	4¼" (108mm)	52¼" (1327mm)	28¼" (718mm)	26⅞" (664mm)	X4X-WW(VT/OT)-24-B
	5¼" (133mm)	53¼" (1353mm)	29¼" (743mm)	26⅝" (676mm)	X5X-WW(VT/OT)-24-B
	6¼" (159mm)	54¼" (1378mm)	30¼" (768mm)	27⅞" (689mm)	X6X-WW(VT/OT)-24-B
36" (914mm)	3½" (89mm)	75½" (1918mm)	39½" (1003mm)	37¾" (959mm)	X3X-WW(VT/OT)-36-B
	4¼" (108mm)	76¼" (1937mm)	40¼" (1022mm)	38⅞" (968mm)	X4X-WW(VT/OT)-36-B
	5¼" (133mm)	77¼" (1962mm)	41¼" (1048mm)	38⅝" (981mm)	X5X-WW(VT/OT)-36-B
	6¼" (159mm)	78¼" (1988mm)	42¼" (1073mm)	39⅞" (994mm)	X6X-WW(VT/OT)-36-B

*Add suffix -V (vented) or -S (solid) to catalog number.
Example: 234-12VT-12-V

90° VERTICAL CABLE SUPPORT ELBOW [SR]

VERTICAL TEE - DOWN (VT)

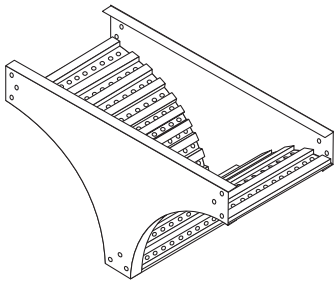

VERTICAL TEE - UP (OT)

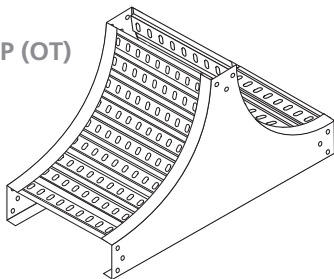

CSA CERTIFIED FOR CSA SYSTEMS

Radius-R	"H" Dim.	"A" Dimension	"B" Dimension	Part Number
12" (305mm)	3½" (89mm)	15½" (394mm)	13¾" (349mm)	X3X-WWSR-12-B
	4¼" (108mm)	16¼" (413mm)	14⅞" (359mm)	X4X-WWSR-12-B
	5¼" (133mm)	17¼" (438mm)	14⅝" (371mm)	X5X-WWSR-12-B
	6¼" (159mm)	18¼" (464mm)	15⅞" (384mm)	X6X-WWSR-12-B
24" (610mm)	3½" (89mm)	27½" (699mm)	25¾" (654mm)	X3X-WWSR-24-B
	4¼" (108mm)	28¼" (718mm)	26⅞" (664mm)	X4X-WWSR-24-B
	5¼" (133mm)	29¼" (743mm)	26⅝" (676mm)	X5X-WWSR-24-B
	6¼" (159mm)	30¼" (768mm)	27⅞" (689mm)	X6X-WWSR-24-B
36" (914mm)	3½" (89mm)	39½" (1003mm)	37¾" (959mm)	X3X-WWSR-36-B
	4¼" (108mm)	40¼" (1022mm)	38⅞" (968mm)	X4X-WWSR-36-B
	5¼" (133mm)	41¼" (1048mm)	38⅝" (981mm)	X5X-WWSR-36-B
	6¼" (159mm)	42¼" (1073mm)	39⅞" (994mm)	X6X-WWSR-36-B

*Add suffix -V (vented) or -S (solid) to catalog number
Example: 234-12SR-12-V

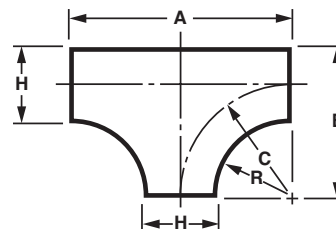

TYPICAL SPECIFICATIONS

By Specifying the NEMA class designation, you will use the simplest, clearest, and most complete method of specification available and automatically incorporate support span in feet, working (allowable) load in pounds per linear foot, a safety factor or 1.5, a concentrated load if present; and, all other design, manufacturing and test standards including electrical continuity.

All you need to add is inside depth, desired radius of fittings (to protect from cable damage), metal and finish. You can add accessory information pursuant to your project. Here is a typical specification for an outdoor tray system where the working (allowable) load has been determined to be approximately 75 pounds per foot on support spans of 12'-0"

SPECIFICATION - ALUMINUM COPE TROF

Cable Trof type tray shall be manufactured by a company regularly engaged in the manufacture of metal cable trays and shall be a member of NEMA. Trays shall conform to NEMA Metal Cable Tray Standard Publication VE-1 (latest issue).

1. Cable Trof shall be NEMA Classification 12B of the widths indicated.
2. Material shall be aluminum alloy with side rails of 6063 and bottoms of 5052 alloy.
3. Finish shall be natural.
4. Inside load depth to be NEMA Standard 3".
5. Fittings shall be 12" radius for control cables and 24" radius for power cables. (This must be commensurate with the cable manufacturer's recommended minimum bending radius.)
6. All top level trays in stacks and single runs to have raised peaked aluminum ventilated covers with heavy duty hold down clamps every 3'-0".
7. Install expansion connectors, expansion guides, and hold down clamps per NEMA Standard VE-1.
8. Where slopes or horizontal bends of trays are not at the Standard NEMA angles use adjustable connectors. If the angle is too great for cable bending radius, use combinations of fitting and adjustable connectors.

9. Separate all cables of different voltages in the same tray using the manufacturer's standard barriers and barrier hold down system.

10. The cable Trof system will be used as an equipment grounding conductor.

11. To save space, fittings shall have no tangents. To facilitate field installation, use one pair of universal type connector plates for rigid joints.

12. Cable Trof shall be three (3) piece construction with corrugated bottoms having 1" wide ribs on 2" centers arc welded to 3½", high side rails. Ventilating holes, 1/16" diameter on 1" centers, shall be provided across valleys of the corrugations. Welds shall be MIG-arc type with approximately ½", diameter fused zone for rigidity to resist the rigors of shipping, installation, and service.

13. Trays shall be Cope Trof as manufactured by Atkore International.

TROF CABLE TRAY SYSTEM

ELECTRICAL GROUNDING CHART

Table 1 below provides the Minimum Cross Sectional area for two side rails. Using the Fitting Prefix Number (244), the proper value is determined by the Material (column 3), the Flange Width (column 1) and Load Depth (column 2). Locate the line containing the Load Depth (column 1) and follow it to the right to the appropriate Flange Width and Material.

Find that value in Table 2, follow it to the right to the Material column to determine the Maximum Ground Fault Amperage.

For Example:

If the fitting prefix is 244, the Flange is 13/16", the Load Depth is 4", and the Material is Aluminum. The Minimum Cross Sectional Area (X-Sect Area) is 0.60 sq.in. The Amperage is 1000.

TABLE 1

Fitting Prefix Number			Min. X-Sect for 2 Rails (NEC Table 392.7B)			
			Aluminum		Steel	
			¹³ / ₁₆ " Flange	1 ¹ / ₄ " Flange	¹³ / ₁₆ " Flange	1 ¹ / ₄ " Flange
Flange	Load Depth	Material	X-Sect Area	X-Sect Area	X-Sect Area	X-Sect Area
2 - ¹³ / ₁₆ "	3"	2 - Mill Gal	0.60	-	0.40	-
4 - 1 ¹ / ₄ "	4"	3 - HDGAF	0.60	0.60	0.40	0.70
	5"	4 - Alum.	0.60	1.00	0.70	0.70
	6"		0.60	1.00	0.70	1.00

TABLE 2

Maximum Ground Fault Amperage (in Amps)		
X-Sect Area	Material	
	Aluminum	Steel
.40 sq in	-	100
.60 sq in	1000	-
.70 sq in	-	200
1.00 sq in	1200	400

For Example:

If the fitting prefix is 244, the Flange is ¹³/₁₆", the Load Depth is 4", and the Material is Aluminum. The Minimum Cross Sectional Area (X-Sect Area) is 0.60 sq.in. The Amperage is 1000.

CONNECTORS & HARDWARE

Universal Curvilinear Connector, Expansion, Horizontal and Vertical Adjustable, Reducing and 90° Connector	102
General Hardware	103

COVERS

Covers, Joint Plate	104
Cover Attachments (Hold Down Clamps, Elevated and Peaked Cover Connectors)	105

ACCESSORIES

Blind End, Drop Out, Bonding Jumper, Box Connector, Cable Tray Ground Clamp, Ground Cable Retainer Clamp	106
Conduit Clamp, Wall Sleeve	107
Barrier Strips, Nylon Protector	108
Hold Down Clamp & Expansion Guide, Seismic Hold Down, Barrier Strip Clamps	109
Channel Supports, Tray Brackets, Support Brackets	110 - 111
Hanger Support, Trapeze Hanger Support, Vertical Supports	111 - 112
Beam Clamps	113 - 114

CONNECTORS

Page 102

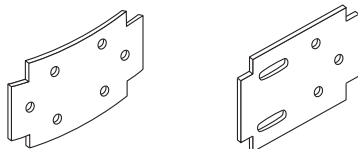

COVER ATTACHMENTS

Page 105

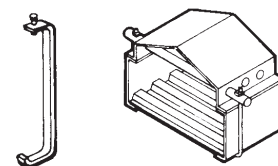

COVERS

Page 104

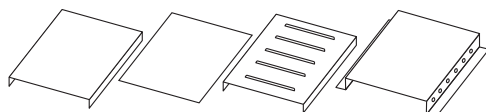

BARRIER STRIPS AND ACCESSORIES

Pages 108 - 109

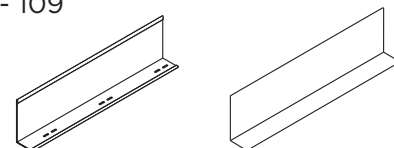

HARDWARE & COVERS

CONNECTOR PLATES - LADDER, HAT, AND TROF

TRAY CONNECTORS

Load Depth	Finish (LADDER)	Finish (HAT & TROF)	Basic No.
3"	6 (Mill Galv.)	2 (Mill Galv.)	-02RC
4"	7 (HDGAF)	3 (HDGAF)	-02CE
5"	8 (Alum.)	4 (Alum.)	-02CV
6"	T (304SS)	U (304SS)	-02CH -02CA

EXAMPLE: 38 -02RC for 3" load depth, aluminum, universal curvilinear connector.

NOTE: Hole patterns match corresponding tray. Three-hole pattern illustrated.

UNIVERSAL CURVILINEAR CONNECTOR [RC]

NOTE: Sold in pairs

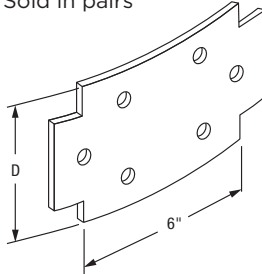

11 Gage Steel, 0.125" Aluminum
3/8"-16 spline bolts & flange nuts furnished.

EXPANSION CONNECTOR [CE]

NOTE: Sold in pairs

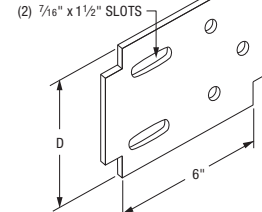

11 Gage Steel, 0.125" Aluminum
3/8"-16 cap screws & Nylok nuts furnished and
3/8"-16 spline bolts & flange nuts furnished.

NOTE: Bonding Jumpers are required and are sold separately.

HORIZONTAL ADJUSTABLE CONNECTOR [CH]

NOTE: Sold in pairs - inner & outer

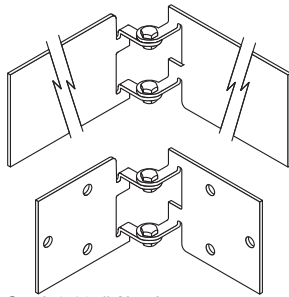

11 Gage Steel, 0.125" Aluminum
3/8"-16 spline bolts & flange nuts furnished.

NOTE: Bonding Jumpers are required and are sold separately.

VERTICAL ADJUSTABLE CONNECTOR [CV]

NOTE: Sold in pairs

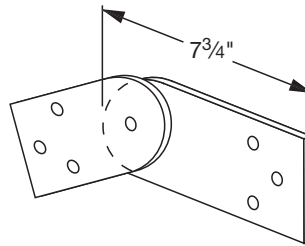

11 Gage Steel, 0.125" Aluminum
3/8"-16 spline bolts & flange nuts furnished.

NOTE: Bonding Jumpers are required and are sold separately.

MID-SPAN SPLICE PLATE [RC]

Catalog Number: 58-02RC-MID

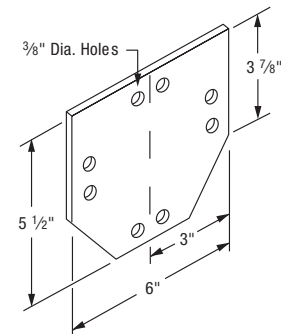

3/8" - Aluminum
For use with 7D58 and 7G58 Systems.

REDUCING CONNECTOR

NOTE: Not sold in pairs

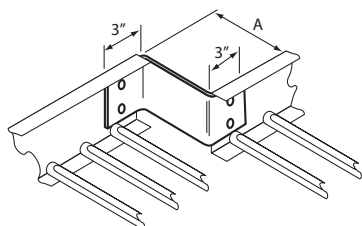

12 Gage Steel, 0.125" Aluminum

For offset reductions - use 1 of above with standard connector plate.

For straight reductions- use 2 (of 1/2 reduction dim.).

3/8"-16 spline bolts and flange nuts furnished.

EXAMPLE: 38-03CO for 3" load depth, aluminum, 3" Reducer Connector.

Typical Use: 9" to 6", or use 2 for 12" to 6", etc.

Catalog Number

Load Depth	Finish (LADDER)	Finish (HAT & TROF)	Basic Number	"A" Dimension
3"	6 (Mill Galv.)	2 (Mill Galv.)	-30CO	30" (762mm)
4"	7 (HDGAF)	3 (HDGAF)	-27CO	27" (686mm)
5"	8 (Alum.)	4 (Alum.)	-24CO	24" (610mm)
6"	T (304SS)	U (304SS)	-21CO	21" (533mm)
			-18CO	18" (457mm)
			-15CO	15" (381mm)
			-13CO	13 1/2" (343mm)
			-12CO	12" (305mm)
			-10CO	10 1/2" (267mm)
			-09CO	9" (229mm)
			-07CO	7 1/2" (191mm)
			-06CO	6" (152mm)
			-04CO	4 1/2" (114mm)
			-03CO	3" (76mm)
			-01CO	1 1/2" (38mm)

90° ANGLE CONNECTOR [CA]

NOTE: Sold in pairs

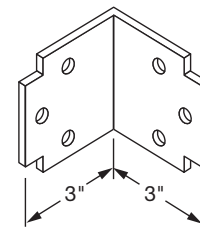

11 Gage Steel, 0.125" Aluminum
3/8"-16 spline bolts & flange nuts furnished.

HARDWARE - LADDER, HAT, AND TROF

MATERIAL/FINISH

Electrogalvanized finish standard. Other finishes available; consult factory.

*Use following suffix when applicable - use only where indicated.

NO SUFFIX Electrogalvanized carbon steel only

-SS 302/304 Stainless Steel

-S1 316 Stainless Steel (check factory for availability)

Example: PS 6024 3/8" x 1 1/2" SS, 3/8" x 1 1/2" hex head bolt, 304 stainless steel

CONNECTOR HARDWARE

(Case-hardened steel electrogalvanized)

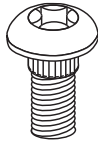

Part No. 5009-1
3/8"-16 hex-flanged nut with serrated washer face.

Part No. 5003-1
3/8"-16 x 1" spline bolt

COVER SCREW [EM]

Part No. EM-CC (electrogalv. steel)
Part No. EM-CC-SS (stainless steel)

No. 10 x 5/8" long, self drilling-self tapping hex head plated steel screw.

Suggested spacing:

Indoor: 8 per 12';
Outdoor: 10 per 12'

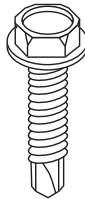

CONTINUOUS THREADED ROD [PS 146]

Cat. No.	Size (Diameter x Length)
PS 146*	1/4" x 10'
PS 146*	3/8" x 10'
PS 146*	1/2" x 10'
PS 146*	5/8" x 10'
PS 146*	3/4" x 10'

(Hot Dip Galvanized not available)

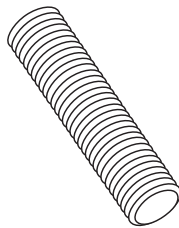

ROD COUPLER [PS 135]

Cat. No.	Size
PS 135*	1/4"
PS 135*	3/8"
PS 135*	1/2"
PS 135*	5/8"
PS 135*	3/4"

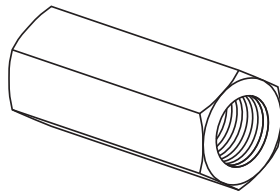

HEX NUTS [PS 83]

Cat. No.	Size
PS 83*	1/4"
PS 83*	3/8"
PS 83*	1/2"
PS 83*	5/8"
PS 83*	3/4"



SQUARE NUTS [PS 6108]

Cat. No.	Size
PS 6108*	1/4"
PS 6108*	3/8"
PS 6108*	1/2"
PS 6108*	5/8"
PS 6108*	3/4"

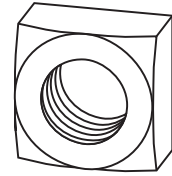

FLAT WASHERS [PS 209]

Cat. No.	Size
PS 209*	1/4"
PS 209*	3/8"
PS 209*	1/2"
PS 209*	5/8"
PS 209*	3/4"

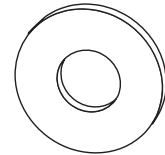

SPLIT-LOCK WASHERS [PS 211]

Cat. No.	Size
PS 211*	1/4"
PS 211*	3/8"
PS 211*	1/2"
PS 211*	5/8"
PS 211*	3/4"

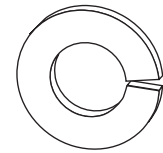

FENDER WASHERS [PS 230]

Cat. No.	Size (I.D. x O.D.)
PS 230*	1/4" x 1 1/4" O.D.
PS 230*	3/8" x 1 1/2" O.D.
PS 230*	1/2" x 2" O.D.

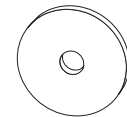

HEX HEAD CAP SCREW / ROUND HEAD, SLOTTED CAP SCREW [PS 6024]

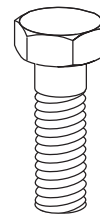

Catalog No. PS 6024

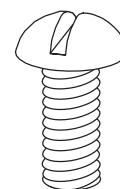

Catalog No. PS 6072

Hex Head Cap Screw Cat. No.	Round Head Cap Screw Cat. No.	Size (Dia. x Len.)
PS 6024*	PS 6072*	1/4" x 1"
PS 6024*	PS 6072*	1/4" x 1 1/2"
PS 6024*	PS 6072*	3/8" x 1"
PS 6024*	PS 6072*	3/8" x 1 1/2"
PS 6024*	PS 6072*	3/8" x 3"
PS 6024*	PS 6072*	1/2" x 1"
PS 6024*	PS 6072*	1/2" x 1 1/2"
PS 6024*	PS 6072*	1/2" x 2"
PS 6024*	PS 6072*	1/2" x 2 1/2"
PS 6024*	PS 6072*	1/2" x 3"
PS 6024*	PS 6072*	1/2" x 3 1/2"
PS 6024*	PS 6072*	5/8" x 1 1/2"
PS 6024*	PS 6072*	5/8" x 2"
PS 6024*	PS 6072*	5/8" x 3"
PS 6024*	PS 6072*	5/8" x 4"
PS 6024*	PS 6072*	3/4" x 2"
PS 6024*	PS 6072*	3/4" x 3"
PS 6024*	PS 6072*	3/4" x 4"

HARDWARE & COVERS

COVERS - LADDER, HAT, AND TROF

For straight sections shown. Standard fitting covers are flat solid type (NF). Aluminum covers are fabricated from 0.040" aluminum AA-3150-H14; steel covers are fabricated from 20 gage ASTM A-653-G90 CQ, mill-galvanized steel.

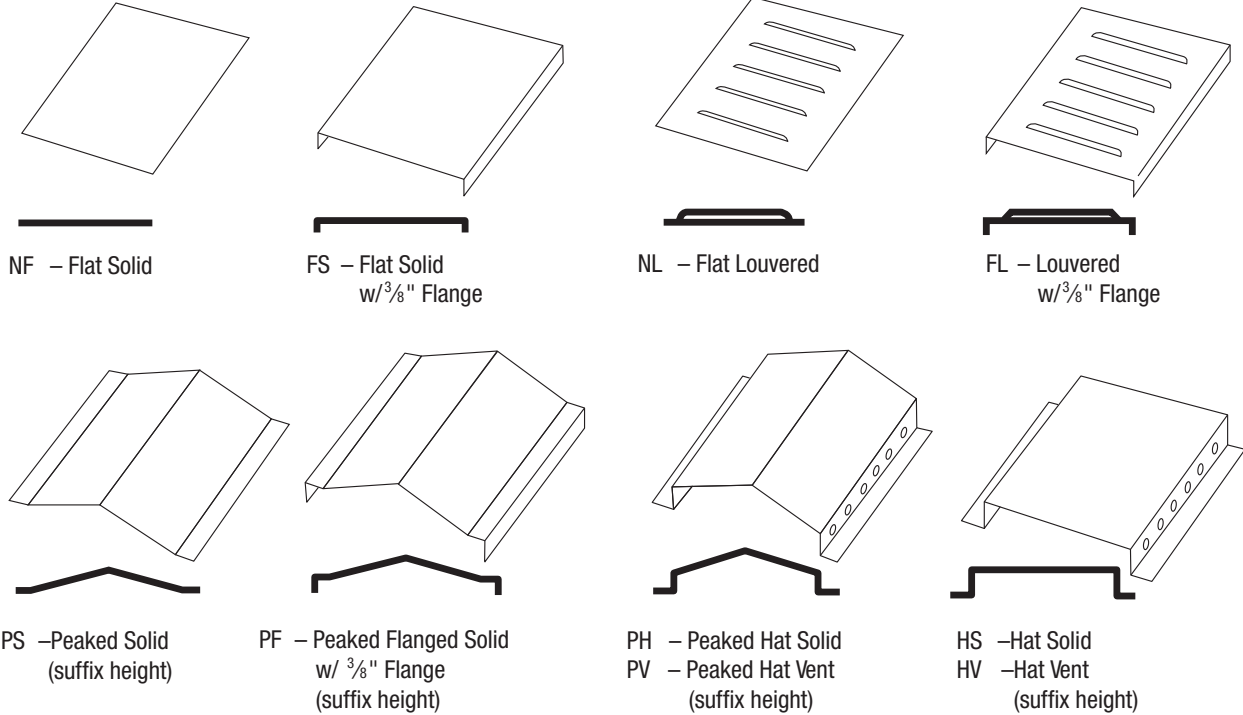

NOTE: Use EM-CC Cover Screws (see pg. 57) to attach PH, PV, HS & HV covers.

Hot dip covers - straights only 6'

Cover Catalog Number - Straight Sections						
Type	Flange (LADDER ONLY)	Finish (LADDER)	Finish (HAT & TROF)	Basic No. (Width)	Length	Height*
HS, HV,	2 - 1 ¹ / ₁₆ "	6 - Mill Galv.	2 - Mill Galv.	-06SL = 6" (152mm)	-06'	-2*
FL, FS,	4 - 1 ¹ / ₄ "	7 - HDGAF	3 - HDGAF	-09SL = 9" (229mm)	-10'	
NF, NL,	5 - 1 ¹ / ₂ "	8 - Alum.	4 - Alum.	-12SL = 12" (305mm)	-12'	
PS, PF,	6 - 1 ¹ / ₄ "	T - 304SS	U - 304SS	-18SL = 18" (457mm)		
PH, PV	7 - 2"			-24SL = 24" (610mm)		
				-30SL = 30" (762mm)		
				-36SL = 36" (914mm)		

*peak and hat only, 2" height standard. Consult factory for other heights.
Example: NL46-09SL-10 is a flat louvered mill-galv. steel cover for a 9" wide mill galvanized ladder 10' long with a 1¹/₄" flange.

Cover Catalog Number - Fittings						
Type	Flange (LADDER ONLY)	Load Depth	Finish (LADDER)	Finish (HAT & TROF)	Width/Basic No.	Radius
NF	2 - 1 ¹ / ₁₆ "	3"	6 - Mill Galv.	2 - Mill Galv.	-06 XX **	12"
FS	4 - 1 ¹ / ₄ "	4"	7 - HDGAF	3 - HDGAF	-09 XX **	24"
		5"	8 - Alum.*	4 - Alum.*	-12 XX **	36"
		6"	T - 304SS	U - 304SS	-18 XX **	
					-24 XX **	
					-30 XX **	
					-36 XX **	

* Load depth for outside riser or vertical tee only.
** XX from fitting selection page 32
Example: NF26-369F-24 is a mill galvanized non-flanged solid cover for a 36" wide horizontal 90° elbow with a 24" radius.

JOINT PLATE

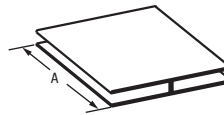

Joint plate is black PVC and is offered in 10' lengths to be field cut to desired length, or in pre-cut lengths for specified covers (e.g., JP-06 is a joint plate for 6" wide tray).

Joint Plate (LADDER)		Joint Plate (HAT & TROF ONLY)		
Part No.	Tray Size	Tray Width		Flange Type
JP-06	6" (152mm)	JP-06 = 6"	(152mm)	
JP-09	9" (229mm)	JP-09 = 9"	(229mm)	-2 = 1 ¹ / ₁₆ " Flange
JP-12	12" (305mm)	JP-12 = 12"	(305mm)	
JP-18	18" (457mm)	JP-18 = 18"	(457mm)	-4 = 1 ¹ / ₄ " Flange
JP-24	24" (610mm)	JP-24 = 24"	(610mm)	
JP-30	30" (762mm)	JP-30 = 30"	(762mm)	-7 = 2" Flange
JP-36	36" (914mm)	JP-36 = 36"	(914mm)	
JP-120	10' for field cut			

Example: JP-06-2 is a joint plate for 6" wide tray with a 1¹/₁₆" flange.

STAINLESS STEEL COVER CLIP [CCS-SS]

1/4" - 28 stainless steel cone point machine screw. Use with any width tray and cover. Not sold in pairs. Indoor use only. Suggest spacing 6' max.

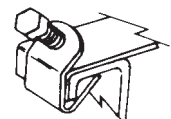

COVER ACCESSORIES - LADDER, HAT, AND TROF

DOUBLE CLAMP CONNECTOR [(W) DC]

For all covers except hat & peak type. Furnished with: (2) 1/4"-20 all-thread rods (4) hex nuts, flat washers and lock washers.

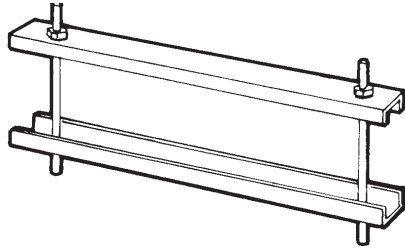

Flange (LADDER ONLY)	Load Depth	Finish (LADDER)	Finish (HAT & TROF)	Width	Type
2=1 3/16"	3"	6=Mill Galv.	2=Mill Galv.	-06	DC
4=1 1/4"	4"	7=HDGAF	3=HDGAF	-09	
5=1 1/2"	5"	8=Alum.	4=Alum.	-12	
6=1 3/4"	6"	T=304SS	U=304SS	-18	
7=2"				-24	
				-30	
				-36	

Suggested spacing:
Indoor: 2 per 12'
Outdoor: 3 per 12'
High Wind: 5 per 12'

Example: 238-12DC for 3" load depth, 1 3/16" flange, aluminum, Double Clamp Connector for Ladder Tray

ELECTRO-GALV. STEEL COVER CLIP [PS 135X]

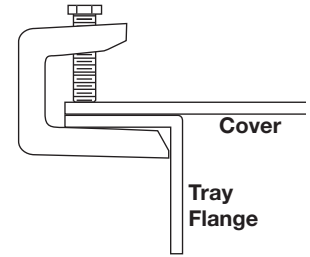
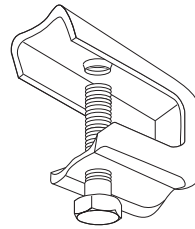

Use with any width tray. Not sold in pairs. Indoor use only. Suggest spacing 6' max.

COVER CONNECTOR [CC]

NOTE: For all covers except hat & peak type

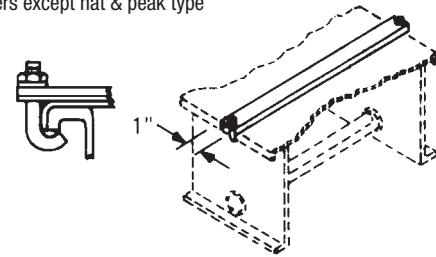

Flange (LADDER ONLY)	Finish (LADDER)	Finish (HAT & TROF)	Width	Type
2=1 3/16"	6=Mill Galv.	2=Mill Galv.	-06	CC
4=1 1/4"	7=HDGAF	3=HDGAF	-09	
5=1 1/2"	8=Alum.	4=Alum.	-12	
6=1 3/4"	T=304SS	U=304SS	-18	
7=2"			-24	
			-30	
			-36	

PEAK COVER CONNECTOR [PC]

NOTE: For PS & PF Covers

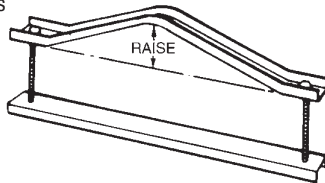

Flange (LADDER ONLY)	Load Depth	Finish (LADDER)	Finish (HAT & TROF)	Width	Type	Raise (in)*
2=1 3/16"	3"	6=Mill Galv.	2=Mill Galv.	-06	PC	-2
4=1 1/4"	4"	7=HDGAF	3=HDGAF	-09		
5=1 1/2"	5"	8=Alum.	4=Alum.	-12		
6=1 3/4"	6"	T=304SS	U=304SS	-18		
7=2"				-24		
				-30		
				-36		

238-12PC-2 for 3" load depth, 1 3/16" flange, aluminum, 12" wide, Peak Cover Connector with 2" peak for Ladder Tray

*2" standard raise. Consult factory for other peak heights.

ELEVATED COVER CONNECTORS [EM-CC]

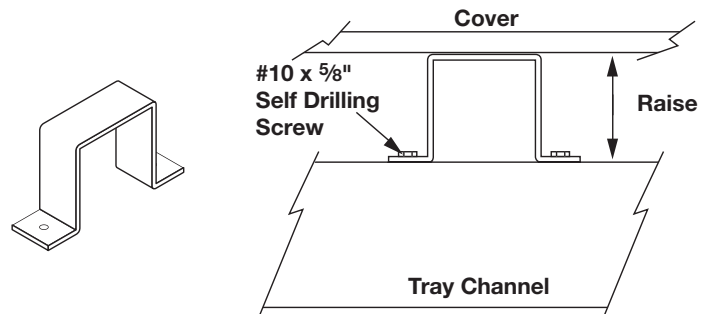

Finish (LADDER)	Finish (HAT & TROF)	Type	Height*
6=Mill Galv.	2=Mill Galv.	EM-CC	- Raise* (in.)
7=HDGAF	3=HDGAF		
8=Alum.	4=Alum.		
T=304SS	U=304SS		

Includes: (3) #10 x 5/8 Self drilling screws.
Suggested spacing:
Indoor: 3/Side (6 tot.) per 12'

PEAK VENT COVER CONNECTOR [VC]

NOTE: For PV Covers

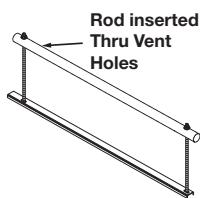

Flange (LADDER ONLY)	Load Depth	Finish (LADDER)	Finish (HAT & TROF)	Width	Type
2=1 3/16"	3"	6=Mill Galv.	2=Mill Galv.	-06	VC
4=1 1/4"	4"	7=HDGAF	3=HDGAF	-09	
5=1 1/2"	5"	8=Alum.	4=Alum.	-12	
6=1 3/4"	6"	T=304SS	U=304SS	-18	
7=2"				-24	
				-30	
				-36	

Example: 238-12VC is for 3" load depth, 1 3/16" flange, aluminum, 12" wide, Peak Vented Cover Connector for Ladder Tray

*1", 2" or 3" standard.

Example: 7-EM-CC-2 for hot dipped galvanized, Elevated Cover Connector with a 2" raise for Ladder Tray

HARDWARE & COVERS

ACCESSORIES - LADDER, HAT, AND TROF

BOX CONNECTOR [CB]

14 Gage Steel, .080" Aluminum.

NOTE: ¼"-20 carriage bolts, flat washers, hex nuts furnished

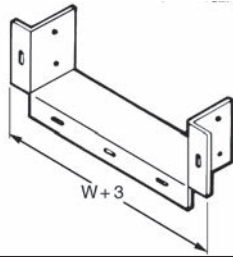

Load Depth	Finish (LADDER)	Finish (HAT & TROF)	Width
3"	6 (Mill Galv.)	2 (Mill Galv.)	-06CB = 6" (152mm)
4"	7 (HDGAF)	3 (HDGAF)	-09CB = 9" (229mm)
5"	8 (Alum.)	4 (Alum.)	-12CB = 12" (305mm)
6"	T (304SS)	U (304SS)	-18CB = 18" (457mm)
			-24CB = 24" (610mm)
			-30CB = 30" (762mm)
			-36CB = 36" (914mm)

Example: 38-12CB for 3" load depth, aluminum, 12" wide, Box Connector.

BLIND END [BE]

22 Gage Steel, .040" Aluminum

NOTE: ¾"-16 spline bolts and flange nuts furnished.

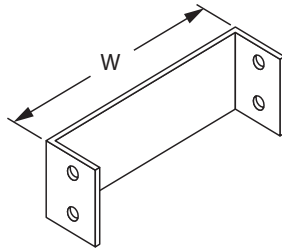

Load Depth	Finish (LADDER)	Finish (HAT & TROF)	Width
3"	6 (Mill Galv.)	2 (Mill Galv.)	-06BE = 6" (152mm)
4"	7 (HDGAF)	3 (HDGAF)	-09BE = 9" (229mm)
5"	8 (Alum.)	4 (Alum.)	-12BE = 12" (305mm)
6"	T (304SS)	U (304SS)	-18BE = 18" (457mm)
			-24BE = 24" (610mm)
			-30BE = 30" (762mm)
			-36BE = 36" (914mm)

Example: 38-12CB for 3" load depth, aluminum, 12" wide, Box Connector.

CABLE TRAY GROUND CLAMP [9156]

Extruded Alum. with ElectroGalvanized Hex Head Screws

Capacity: #6 AWG to 250 kcmil

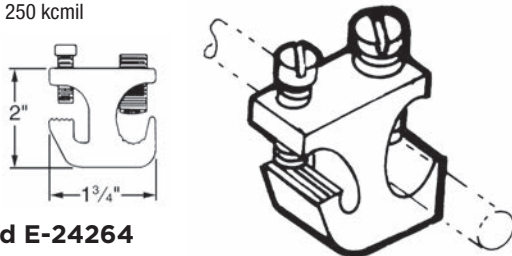

UL Listed E-24264

Certified File No. LR 9795



DROP OUT [DO]

14 Gage Steel, .080" Aluminum.

NOTE: (2) #10 x 5/8" self tapping screws furnished.

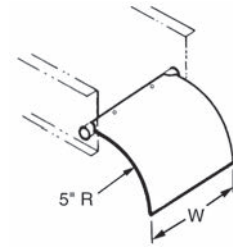

Finish (LADDER)	Finish (HAT & TROF)	Width
6 (Mill Galv.)	2 (Mill Galv.)	-06DO = 6" (152mm)
7 (HDGAF)	3 (HDGAF)	-09DO = 9" (229mm)
8 (Alum.)	4 (Alum.)	-12DO = 12" (305mm)
T (304SS)	U (304SS)	-18DO = 18" (457mm)
		-24DO = 24" (610mm)
		-30DO = 30" (762mm)
		-36DO = 36" (914mm)

Example: 8-12DO for aluminum, 12" wide, Drop Out for Ladder Tray

BONDING JUMPER [CBJ]

NOTE: No hardware supplied

For hardware kit add -HDW:

Ex: CBJ-C-HDW includes
2ea CBJ-C
4ea 5003-1
4ea 5009-1

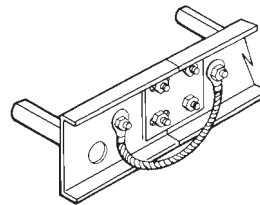

Catalog No.	Dimensional Data	Amperes as Equipment Ground
CBJ-C	AWG 1/0 copper wire 15½" long overall	800 amperes
CBJ-4C	AWG 4/0 copper wire 15½" long overall	1,600 amperes
CBJ-250C	250 MCM copper wire 15½" long overall	2,000 amperes

Example: 38-12CB for 3" load depth, aluminum, 12" wide, Box Connector.

GROUND CABLE RETAINER CLAMP

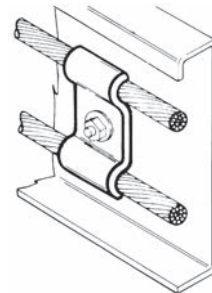

Catalog No.	Capacity	Metal & Finish	Dimensions
9056-EP	1/0 2/0 3/0	Electro-Galv. Steel	1" w x 2" long
9057-EP	4/0 250 MCM	Electro-Galv. Steel	1" w x 2 3/8" long
9056-SS	1/0 2/0 3/0	Stainless Steel	1" w x 2" long
9057-SS	4/0 250 MCM	Stainless Steel	1" w x 2 3/8" long

ACCESSORIES - LADDER, HAT, AND TROF

CONDUIT CLAMP BRACKET



Catalog No.	Size-Rigid	Size-EMT
CCB-050	3/8" to 1/2"	1/2"
CCB-075	3/4"	3/4"
CCB-100	1"	1"
CCB-125	-	1 1/4"
CCB-150	1 1/4"	1 1/2"
CCB-200	2"	2"

CONDUIT-TO-CABLE TRAY CLAMP SWIVEL TYPE

Malleable iron hub and steel "U" bolt. For connecting and grounding rigid conduit to tray at any angle within 90° arc. U.L. listed as a grounding means.

Catalog No.	Size	Std. Pkg.
TB6209	1/2"-3/4"	10
TB6211	1"-1 1/4"	10
TB6214	1 1/2"-2"	5
TB6216	2 1/2"-3"	5
TB6218	3 1/2"-4"	2



WALL PENETRATING SLEEVE ASSEMBLY

Part No. SS89042(W)*

W = Tray Width

*=Fitting 3-Digit Prefix

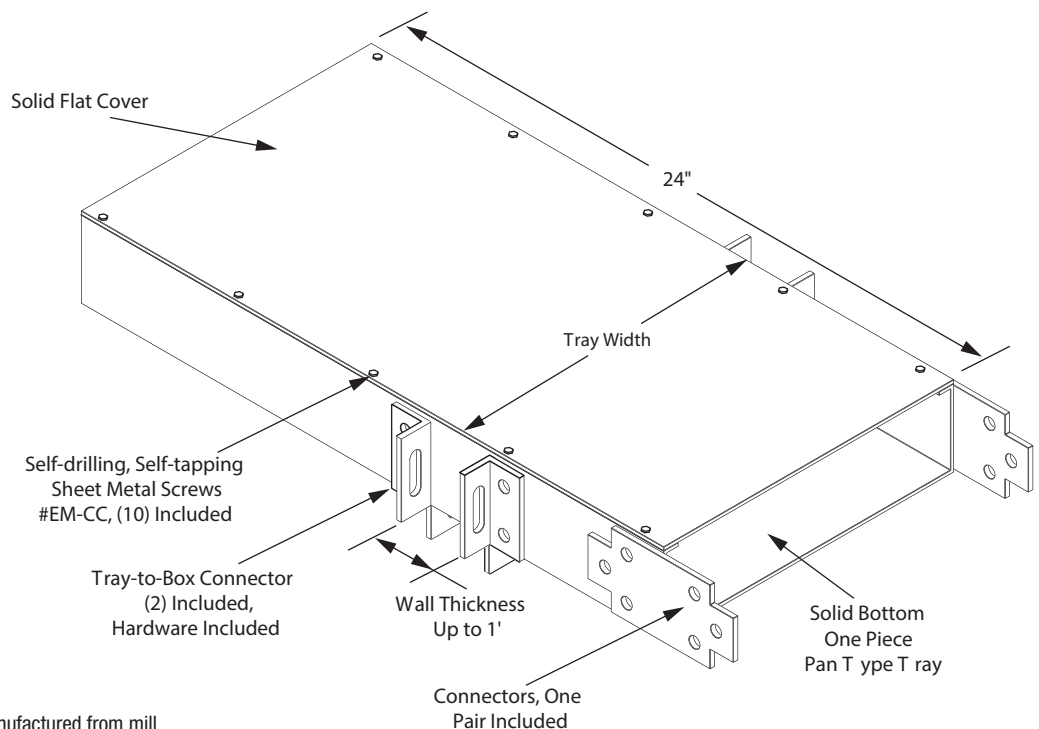

NOTE: Standard penetration sleeves are manufactured from mill galvanized steel. Aluminum sleeves are available upon request.

HARDWARE & COVERS

BARRIER STRIPS - LADDER, HAT, AND TROF

UNIVERSAL ALUMINUM BARRIER STRIP - STRAIGHT SECTION [SB]

Load Depth	Finish	Basic No. 12' Length
3	A (Alum.)	-01SB-12
4		
5		
6		

Example: 3A-01SB-12 for 3" load depth, aluminum straight barrier, 12' long.

Furnished with 8 self tapping screws.

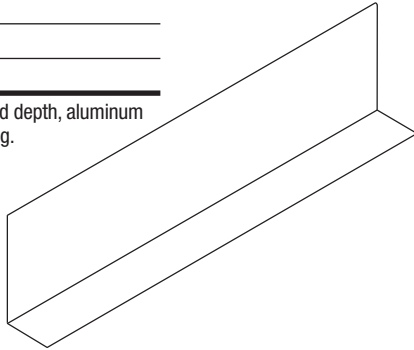

BARRIER STRIP - STRAIGHT SECTION [SB]

Load Depth	Finish (LADDER)	Finish (HAT & TROF)	Basic No. 12' Length
3"	6 (Mill Galv.)	2 (Mill Galv.)	-01SB-12
4"	7 (HDGAF)	3 (HDGAF)	
5"	8 (Alum.)	4 (Alum.)	
6"	T (304SS)	U (304SS)	

Example: 46-01SB-12 for 4" load depth, mill galvanized straight barrier, 12' long.

Furnished with 4 barrier strip clamps and necessary hardware. (SB-HDW)

* Long lead time item - See Universal aluminum barrier strip to the left

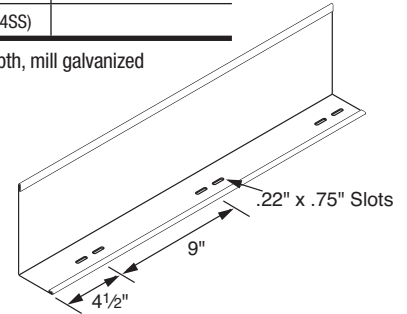

BARRIER STRIP - HORIZONTAL FITTING [FB]

Load Depth	Finish (LADDER)	Finish (HAT & TROF)	Basic No. 12' Length
3"	6 (Mill Galv.)	2 (Mill Galv.)	-01FB-06
4"	7 (HDGAF)	3 (HDGAF)	
5"	8 (Alum.)	4 (Alum.)	
6"	T (304S)		

Example: 38-01FB-06 for fitting barrier, 6'

Furnished with 4 barrier strip clamps and necessary hardware.

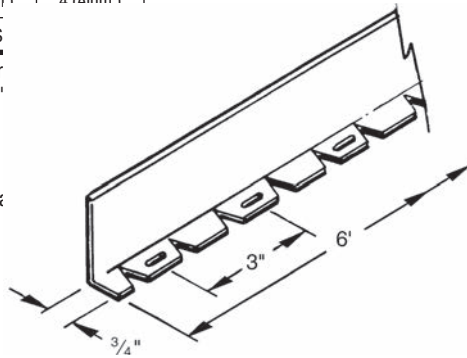

BARRIER STRIP CLAMP [SB-HDW]

Includes: (1) U-Bolt 707981505
(2) Acorn Nuts 707671500

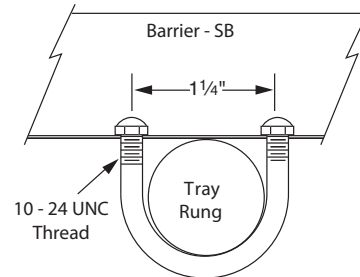

BARRIER STRIP CLAMP (OPTIONAL) [50172]

Load Depth	Finish (LADDER)	Finish (HAT & TROF)	Basic No.
3"	6 (Mill Galv.)	2 (Mill Galv.)	-01FB-06
4"	7 (HDGAF)	3 (HDGAF)	
5"	8 (Alum.)	4 (Alum.)	
6"	T (304SS)	U (304SS)	

Example: 34-5072 for 3" load depth, aluminum clamp.

No. 10 bolt, nut, washer and lock washer furnished.

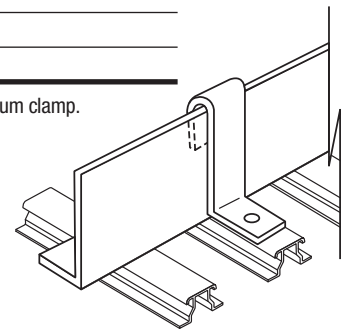

BARRIER STRIP VERTICAL ELBOW OUTSIDE [OB] & INSIDE [IB] (OB SHOWN)

Furnished with sufficient clamp assemblies for installation. Additional clamp assemblies may be ordered separately.

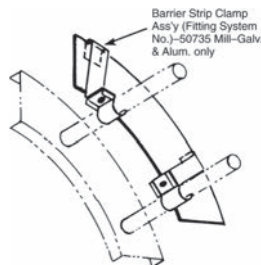

Load Depth	Finish (LADDER)	Finish (HAT & TROF)	Bend (deg.)	Basic No.	Radius
3"	6 (Mill Galv.)	2 (Mill Galv.)	90	OB = Outside	12" (305mm)
4"	7 (HDGAF)	3 (HDGAF)	60	IB = Inside	24" (610mm)
5"	8 (Alum.)	4 (Alum.)	45		36" (914mm)
6"	T (304SS)	U (304SS)	30		

Example: 38-90OB-12 for 3" load depth, aluminum 90° outside vertical barrier with 12" radius.

NYLON BARRIER SPLICE & PROTECTOR [BSP-L]

Prefix	Length
BSP	-5 (5" Splice)
	-144 (144" Protector)
	-1200 (100' Roll)

Example: BSP-1200 for 100' roll

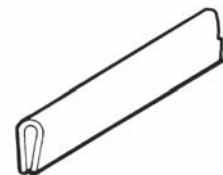

ACCESSORIES - LADDER, HAT, AND TROF

COMBINATION HOLD-DOWN CLAMP & EXPANSION GUIDE [9131] (LADDER ONLY)

Catalog No.	Material
9131	Cast Zinc
9131L	316 Type Stainless Steel
9131A	Aluminum

Catalog No. 9131-HDW
(Complete Hardware Kit)
Hardware Kit List:
(2) Hold-Down Clamps
(2) 1/2" - 13 x 1 1/2" Cap Screws
(2) 1/2" Flat Washer
(2) Clamping Nut (Strut Nut)

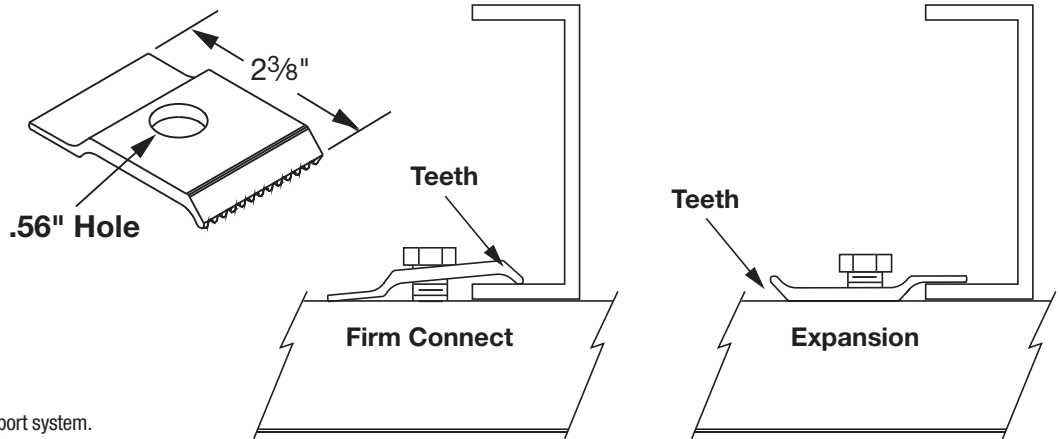

Hardware purchased separately to suit support system.

HOLD-DOWN [9132]

NOTE: For seismic applications or other bolted connections is preferred.

Catalog No.	Material
9132	Mill Galvanized
9133	Stainless Steel

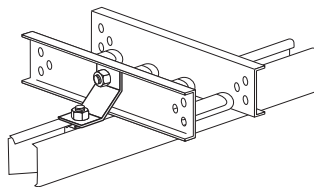

Hardware purchased separately to suit support system.

COMBINATION HOLD-DOWN / EXPANSION GUIDE [9053] (LADDER ONLY)

Universal Guide: for either side of ladder. Use when tray is mounted on I-beams or channels. No drilling required.

Type	Catalog No.	Finish
Combination Guide	6-9053	Elec. Galv.
Combination Guide	8-9053	Aluminum

NOTE: Use set screws for firm hold down.

NOTE: Electroplated set screws included

HOLD-DOWN CLAMP & EXPANSION GUIDE

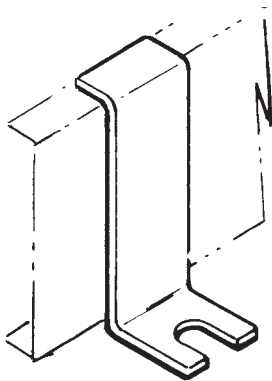

Load Depth.	Basic No.
3	-9039 (Aluminum)
4	-9040 (ElectroGalv.Steel)
5	-9041 (HDGAF)
6	-9042 (316SS)

Example: 3-9039-EX for 3" load depth, expansion guide.

Complete Kit add "-HDW" to Part Number above.
Hardware Kit List:
(2) Hold-Down Clamps
(2) 1/2" - 13 x 1 1/2" Cap Screws
(2) 1/2" Flat Washer
(2) Clamping Nut (Strut Nut)

Hardware purchased separately to suit support system.

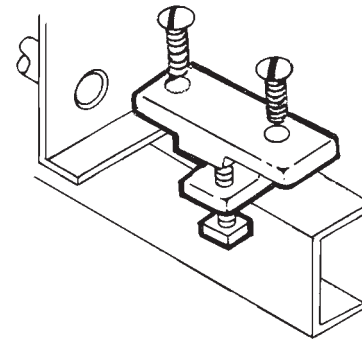

ISOLATION PAD [9131-IP]

The Isolation pad provides protection from galvanic corrosion when Aluminum tray is mounted on steel supports.

NOTE: For use with the 9131A shown above.

Hardware purchased separately

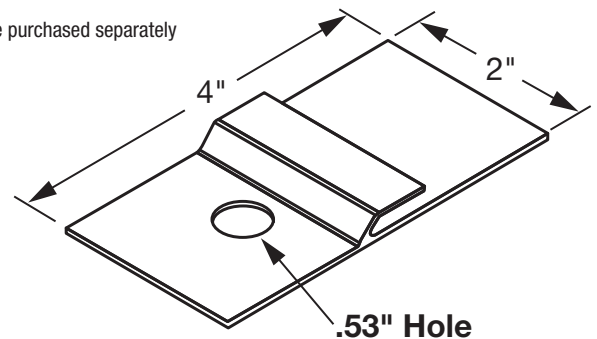

COVER SCREW

Part No. EM-CC (electroGalv. steel)
Part No. EM-CC-SS (stainless steel)

No. 10 x 5/8" long, self drilling-self tapping hex head plated steel screw.

Suggested spacing:
Indoor: 8 per 12';
Outdoor: 10 per 12'

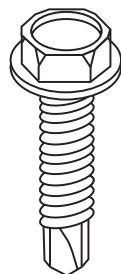

HARDWARE & COVERS

SUPPORTS - LADDER, HAT, AND TROF

VERTICAL SUPPORTS

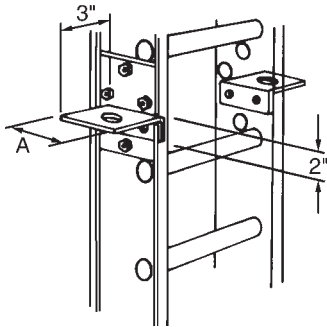

Catalog No.	For Use With
9043-37	4 1/4" Overall Height Side Members
9043	5 1/4" Overall Height Side Members
9025-98	6 1/4" & 7 1/4" Overall Height Side Members

Ladder Supports can be bolted anywhere along the straight runs. They can be bolted directly onto the coupler plates at splices of straight runs and riser fittings, or they can be bolted at any place in the run by field-drilling side rails. Ladder supports are used with either 3/8" or 1/2" hanger rods.

Finish is electrogalvanized.

GUSSET-TYPE SUPPORTS

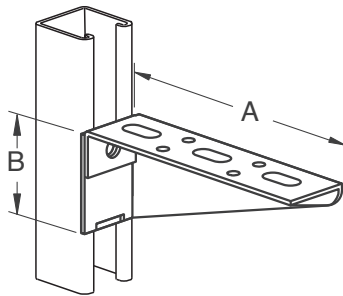

For use with all types of Cope Ladder and Trof systems. Finish is electro-galvanized. Order hardware separately.

Catalog No.	Tray Width	Dim. A	Dim. B	Uniform-Load Rating*
PS 838R-6	-	6"	1 15/16"	275 lbs.
PS 838R-8	-	8"	2 7/16"	275 lbs.
PS 838R-10	-	10"	2 15/16"	275 lbs.
PS 838R-12	6"	12"	3 7/16"	275 lbs.
PS 838R-16	9"	16"	4 7/16"	275 lbs.
PS 838R-18	12"	18"	4 15/16"	275 lbs.
PS 838R-24	18"	24"	6 7/16"	275 lbs.
PS 838R-30	24"	30"	7 15/16"	275 lbs.

CHANNEL-TYPE SUPPORTS

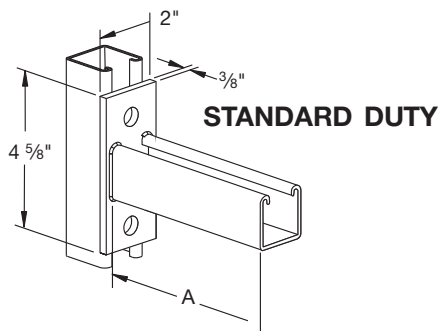

For use with all types of Cope Ladder and Trof systems. Finish is electro-galvanized. Order hardware separately.

Standard Duty for Lighter Loads

Catalog No.	Ladder Width	Dimension "A"	Uniform-Load Rating*
PS 651-6	-	6"	1,200 lbs.
PS 651-12	6"	12"	600 lbs.
PS 651-15	9"	15"	480 lbs.
PS 651-18	12"	18"	400 lbs.
PS 651-24	18"	24"	300 lbs.
PS 651-30	24"	30"	240 lbs.
PS 651-36	30"	36"	-

* Mounted on 12 Ga. Channel.

DOUBLE CHANNEL-TYPE SUPPORTS

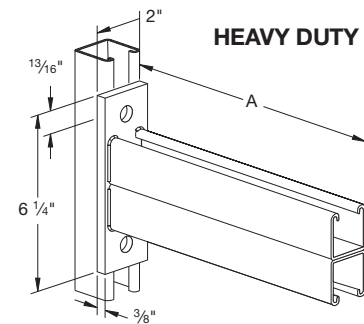

For use with all types of Cope Ladder and Trof systems. Finish is electro-galvanized. Order hardware separately.

Heavy Duty for Heavier Loads

Catalog No.	Ladder Width	Dimension "A"	Uniform-Load Rating*
PS 809-12	6"	12"	2,000 lbs.
PS 809-15	9"	15"	1,600 lbs.
PS 809-18	12"	18"	1,330 lbs.
PS 809-24	18"	24"	1,000 lbs.
PS 809-30	24"	30"	800 lbs.
PS 809-36	30"	36"	660 lbs.
PS 809-42	36"	42"	570 lbs.

* Mounted on 12 Ga. Channel.

SUPPORT BRACKETS & TRAY HANGERS - LADDER, HAT, AND TROF

Intro
LADDER
HAT
TROF
HARDWARE
I-BEAM
CHANNEL
COPE-GLAS™
WIRE BASKET
Reference

WALL SUPPORT BRACKETS

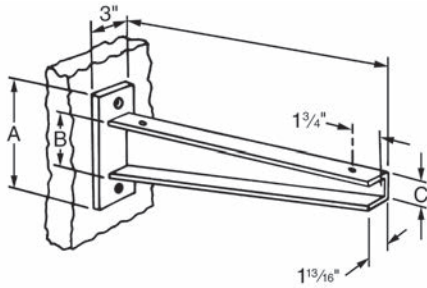

Catalog No.	Ladder Width	Length L	A	B	C	End-Load Rating*
9037-12	6"	12 1/4"	10"	6"	2"	2000 lbs.
9037-18	12"	18 1/4"	11"	7"	2 1/2"	2000 lbs.
9037-24	18"	24 1/4"	11"	7"	2 1/2"	1600 lbs.
9037-30	24"	30 1/4"	12"	8"	4"	1300 lbs.
9037-36	30"	36 1/4"	12"	8"	4"	1100 lbs.
9037-42	36"	42 1/4"	12"	8"	4"	900 lbs.

*Uniform load rating is normally twice the end-load rating.
Finish is hot-dip galvanized after fabrication.
Order hardware separately

STRUCTURAL SUPPORT BRACKET

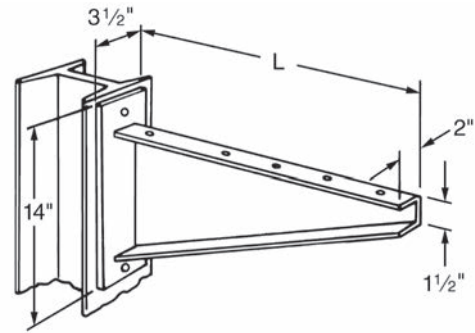

Catalog No.	Ladder Width	Length L	End-Load Rating*
9036-31	24"	31 1/4"	2000 lbs.
9036-37	30"	37 1/4"	1800 lbs.
9036-45	36"	45 1/4"	1500 lbs.

*Uniform load rating is normally twice the end-load rating.
For use with Cope Ladder 24" or wider. May be welded or bolted to building steel.
Finish is hot-dip galvanized after fabrication.
Order hardware separately.

TRAY HANGER

*Uniform load rating is normally twice the end-load rating.
Finish is hot-dip galvanized after fabrication.
Order hardware separately

Use 1/2" Diameter Threaded Rod with Washer & Nut

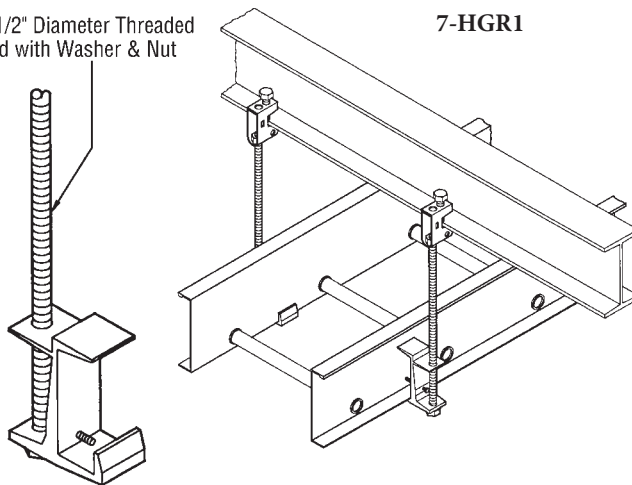

SINGLE LADDER HANGERS

Cope Ladder Hangers are sized according to the side rail height and flange dimensions of various Cope ladders. The 1 7/32" holes accommodate either 3/8" or 1/2" diameter threaded rod.

Order hardware separately.
Finish is Mill-Galv., HDGAF, or Aluminum.

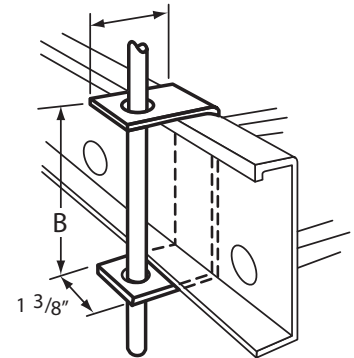

Basic No.	M.G.	Finish H.D.G.	Alum.	Side Rail	"A" Dim.	"B" Dim.
9038-	236	237	238	4 1/4 x 1 3/16	2"	4 5/16
9038-	246	247	248	5 1/4 x 1 3/16	2"	5 5/16
9038-	256	257	258	6 1/4 x 1 3/16	2"	6 5/16
9038-	266	267	268	7 1/4 x 1 3/16	2"	7 5/16
9038-	436	437	438	4 1/4 x 1 1/4	2 9/16	4 5/16
9038-	446	447	448	5 1/4 x 1 1/4	2 9/16	5 5/16
9038-	456	457	458	6 1/4 x 1 1/4	2 9/16	6 5/16
9038-	466	467	468	7 1/4 x 1 1/4	2 9/16	7 5/16

HARDWARE & COVERS

TRAY HANGERS & SUPPORTS - LADDER, HAT, AND TROF

SINGLE ROD HANGER SUPPORT

Assy. Type	Channel Length*	Channel Finish**	Rod Diameter	Rod Length	Beam Clamp
P200	14" (356mm)	GV (Pre-Galv)	3/8" (9.53mm)	000 - No Rod	A - Bridgeport
	17" (432mm)		1/2" (12.7mm)	036 - 36" (914mm)	B - P2622
	20" (508mm)	HG (Hot Dipped Galv)		072 - 72" (1828mm)	O - No Clamp
	26" (661mm)			120 - 120" (3048mm)	R - Rod Coupler
	32" (813mm)			144 - 144" (3658mm)	S - Special
	38" (966mm)				
	44" (1118mm)				

Example: P20020GV12036B is a Single 20" pre-galvanized channel with 1/2" x 36" drop rod and P2622 clamp.

Note:

* Order channel length 8" longer than tray width.

For example, 44" channel for 36" tray.

** Other channel types and finishes available upon request. Contact factory.

To order hardware only:

3/8" - PGV380000

1/2" - PGV120000

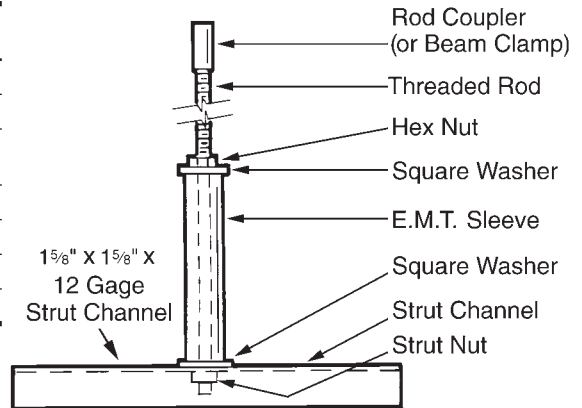

TRAPEZE HANGER SUPPORT

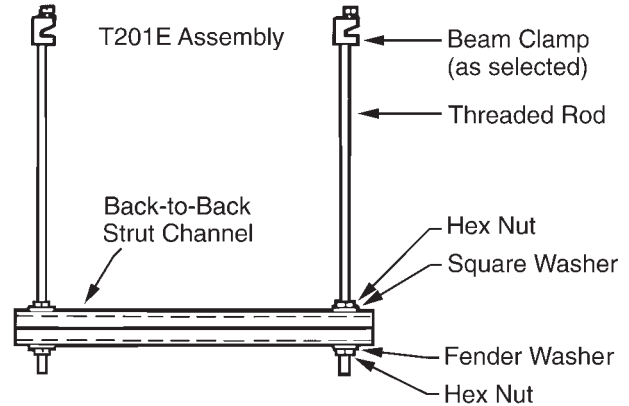
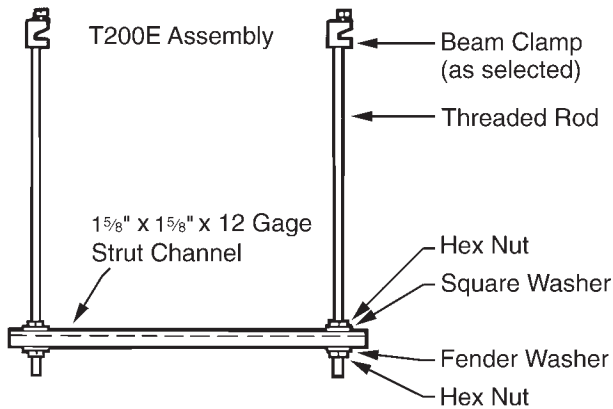

Assy. Type	Channel Length*	Channel Finish**	Rod Diameter	Rod Length	Beam Clamp
P200	16" (407mm)	GV (Pre-Galv)	3/8" (9.53mm)	000 - No Rod	A - PS 85
	19" (483mm)	HG (Hot Dipped Galv)	1/2" (12.7mm)	036 - 36" (914mm)	B - P2622
	22" (559mm)			072 - 72" (1828mm)	O - No Clamp
	28" (712mm)			120 - 120" (3048mm)	R - Rod Coupler
	34" (864mm)			144 - 144" (3658mm)	S - Special
	40" (1017mm)				
	46" (1169mm)				

Example: T200E22GV12036B is a Single 22" pre-galvanized channel with 1/2" x 36" drop rod and P2622 clamp.

Note:

* Order channel length 10" longer than tray width. For example, 46" channel for 36" tray.

** Other channel types and finishes available upon request. Contact factory.

To order hardware only:

3/8" - PGV380000

1/2" - PGV120000

BEAM CLAMPS

Intro
LADDER
HAT
TROUGH
HARDWARE
I-BEAM
CHANNEL
COPE-GLASS™
WIRE BASKET
Reference

PS 686 - BEAM CLAMP

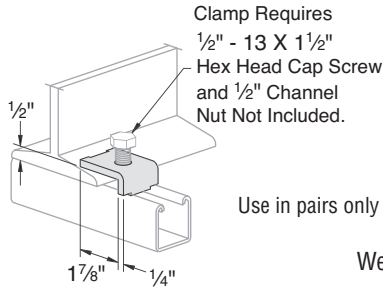

Use in pairs only

Load Rating:
600 lbs. with 12 ga. channel
500 lbs. with 14 ga. channel
Weight/100 pcs: 26 lbs.

PS 736 - HOOK ROD ASSEMBLY

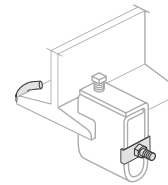

Part No.	Flange Width		A Size	Wt./100 pcs
	Max	Min		
PS 736 J6	7"	3"	8 5/8"	24
PS 736 J10	11"	7"	12 5/8"	33

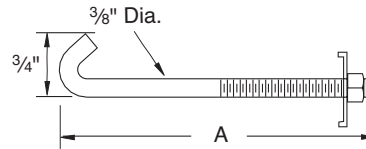

PS 2624 - WOOD BEAM HANGER

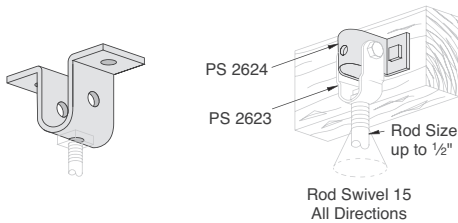

Weight/100 pcs: 22 lbs.

PS 2622 - BEAM CLAMP

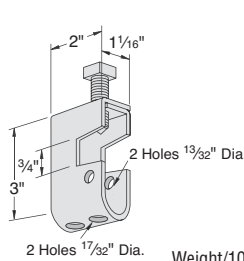

Weight/100 pcs: 41 lbs.

Assembly including PS 736 also available.
Order PS 2622/J6 or PS 2622/J10
Load Rating: 300 lbs.
Note:
Adaptable for 1/4", 3/8" & 1/2" rod with PS 3201.

PS 2623 - SWIVEL ADAPTOR

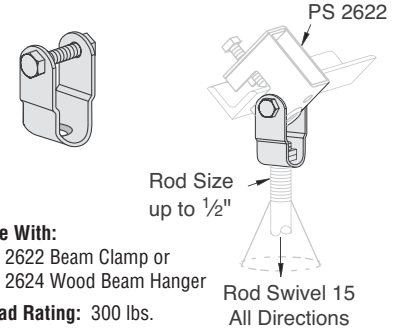

Use With:
PS 2622 Beam Clamp or
PS 2624 Wood Beam Hanger
Load Rating: 300 lbs.

PS 2626 - BEAM CLAMP

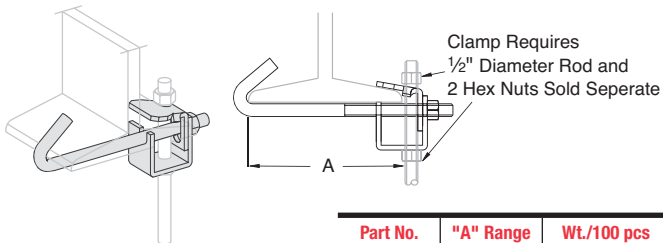

Finish: Plain, painted green or electro-galvanized

Load Rating: 500 lbs.

Part No.	"A" Range	Wt./100 pcs
PS 2626 6	2 1/2" - 6"	125
PS 2626 9	5 1/2" - 9"	140
PS 2626 12	8 1/2" - 12"	171

PS 871 - SAFETY ANCHOR STRAP

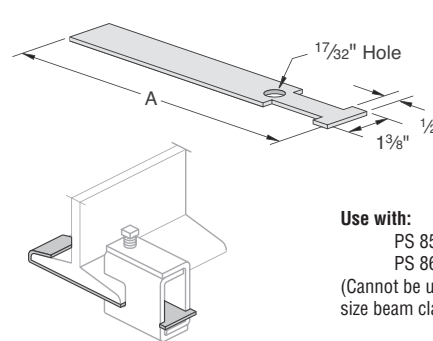

"A" Length	Wt./100 pcs
9"	33
12"	45
15"	57

Use with:
PS 858,
PS 865
(Cannot be used with 5/8" rod size beam clamps and larger)

PS 858 - HEAVY DUTY BEAM CLAMP

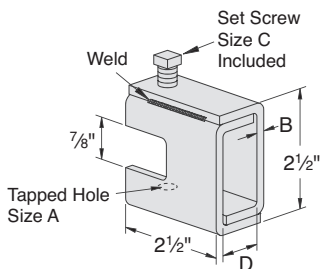

Weld is not continuous it is either 1 1/4" - 1 3/4" long or 2 spot welds. All welds are on the top and bottom.

Part No.	"A" Rod Size	B	C	D	Load Ratings lbs.	Wt./100 pcs
PS 858 1/4	1/4" - 20	1/8"	3/8" x 1 1/2	7/8"	650	67
PS 858 5/16	5/16" - 18					67
PS 858 3/8	3/8" - 16	3/16"	1/2" x 1 1/2	15/16"	1,100	100
PS 858 1/2	1/2" - 13	1/4"				130
PS 858 5/8	5/8" - 11	5/16"	5/8" x 1 1/2	1 1/16"	2,400	160
PS 858 3/4	3/4" - 10					160

For beams under 7/8" thick flange.

HARDWARE & COVERS

BEAM CLAMPS

PS 865 - WIDE THROAT HEAVY DUTY BEAM CLAMP

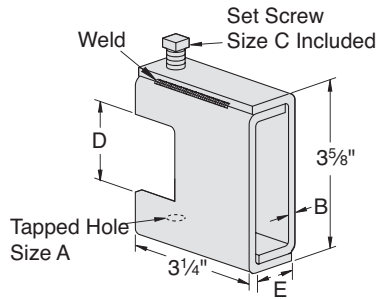

Weld is not continuous it is either 1 1/4" - 1 3/4" long or 2 spot welds. All welds are on the top and bottom.

Part No.	Rod Size	B	C	D	E	Load Ratings lbs.	Wt./100 pcs
PS 865 3/8"	3/8"	3/16"	1/2"	1 1/16"	29/32"	1,100	151
PS 865 1/2"	1/2"	1/4"			15/16"	1,600	195
PS 865 5/8"	5/8"	5/16"			1 5/16"	2,400	225

For beams between 3/4" (19) to 1 1/8" (41) thick flanges.

PS 95 - "C" CLAMP

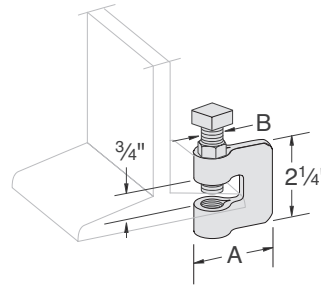

Material: Steel

Rod Size	A	B	Load Rating	Wt./100 pcs
3/8"	2 5/16"	3/8"	330	35
1/2"	2 1/4"	1/2"	380	41
5/8"	2 3/8"	5/8"	450	67
3/4"	2 1/4"	1/2"	500	72

PS 86 - "C" CLAMP

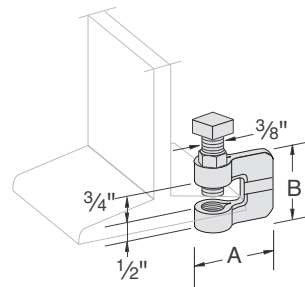

Material: Malleable Iron, Steel Set Screw

Rod Size	A	B	Load Rating	Wt./100 pcs
3/8"	1 11/16"	1 3/4"	400	38
1/2"	1 23/32"			52
5/8"	1 15/16"	2"	600	68
3/4"	2 1/32"			128

PS 93 - UNIVERSAL "C" CLAMP

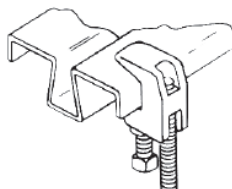
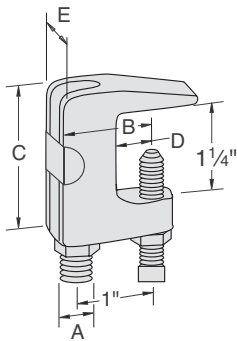

At least one full thread must be exposed

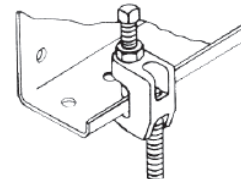

Part No.	Rod Size A	DIMENSIONS (Inches)				Max. Pipe Size	Max. Load (Lbs.)	Wt./100 pcs
		B	C	D	E			
PS 93 3/8"	3/8"	1 1/8"	2	3/4"	7/8"	2	400	28
PS 93 1/2"	1/2"	1 1/8"	2	3/4"	7/8"	3 1/2"	500	34

Material: Malleable Iron, Steel Set Screw

• Maximum temperature of 450° F.

PS 94 - WIDE THROAT TOP BEAM "C" CLAMP

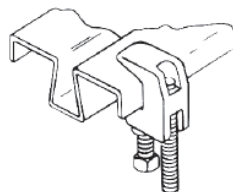
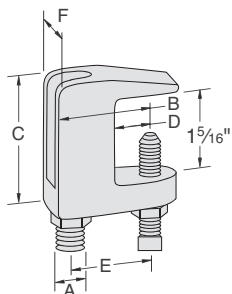

At least one full thread must be exposed

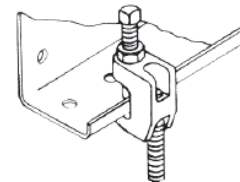

Part No.	Rod Size A	DIMENSIONS (Inches)					Max. Pipe Size	Max. Load (Lbs.)	Wt./100 pcs
		B	C	D	E	F			
PS 94 3/8"	3/8"	1 3/4"	2 1/4"	3/4"	1 1/4"	1	5	600	66
PS 94 3/4"	3/4"	1 7/8"	2 3/8"	3/4"	1 3/8"	1 1/4"	8	800	83

Material: Malleable Iron, Steel Set Screw

• Maximum temperature of 450° F.

7



I-BEAM



I-BEAM CABLE TRAY SYSTEM

CONTENTS

GENERAL & TECHNICAL INFORMATION

Pictorial Index	117
Selection Chart, Straight Length, Load information	118 - 119
Straight Length & Ordering Information	120
Suggested Fittings	121

COPE I-BEAM FITTINGS

Horizontal Elbows	
90°	122
60°	123
45°	124
30°	125
Horizontal Tee	126
Horizontal Tapped Tee	127
Horizontal Cross	128
Horizontal Tapped Cross	129
Straight Reducers	130
Left and Right Hand Reducers	130
45°"Y" Branch	131
Vertical Elbows (Inside and Outside)	
90°	132
60°	133
45°	134
30°	135
90° Vertical Cable Support Elbow	136
Vertical Tee	136

CONNECTORS & HARDWARE

Horizontal Adjustable Connector, Expansion Connector, Universal Connector, Reducing Connector, Mid-Span Splice Plate	137
Vertical Hanger Splice Plate, Hold Down Brackets, Adjustable Vertical Connectors	138
Hold Down Clamp and Expansion Guide, Cable Clamp, Isolation Pad, Box Splice Plates.....	139
General Hardware, Threaded Rod	140

COVERS

Covers, Joint Plate.....	141
Cover Attachments (Hold Down Clamps, Elevated and Peaked Cover Connectors, Steel Cover Clip).....	142

ACCESSORIES

Blind End, Drop Out, Bonding Jumper, Box Connector	
Cable Tray Ground Clamp, Ground Cable Retainer Clamp	143
Conduit & Pipe Clamps, Wall Sleeve Assembly.....	144
Barrier Strips and Barrier Strip Clamps.....	145
Support Brackets	146-147
Tray Brackets, Rooftop Support System.....	147
Hanger Support, Trapeze Hanger Support	148

SPECIFICATION INFORMATION

Electrical Grounding Chart.....	149
Typical Specification.....	149

STRAIGHT LENGTH

Pages 118 - 120

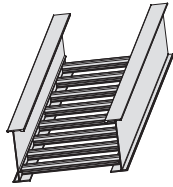

VERTICAL TEE & 90° VERTICAL SUPPORT

Page 136

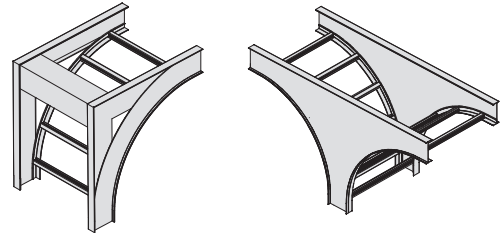

HORIZONTAL ELBOWS

Pages 122 - 125

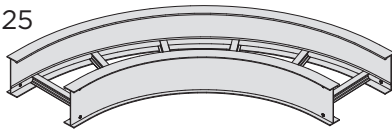

CONNECTORS & HARDWARE

Pages 137 - 140

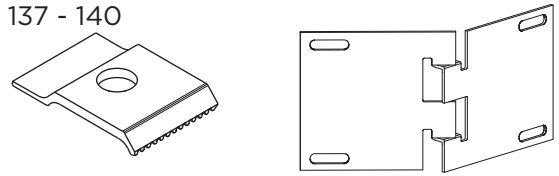

HORIZONTAL TEE

Pages 126 - 127

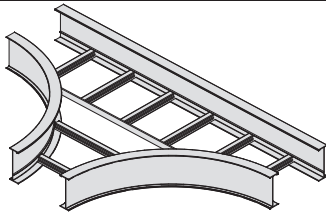

COVERS

Page 141

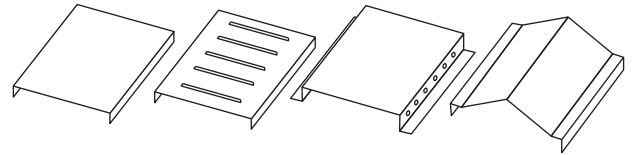

HORIZONTAL CROSS

Pages 128 - 129

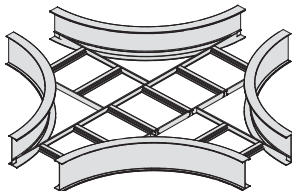

COVER ATTACHMENTS

Page 142

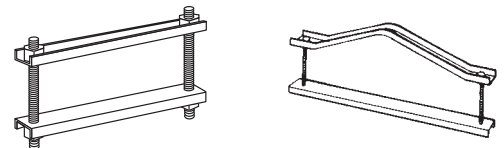

REDUCERS

Page 130

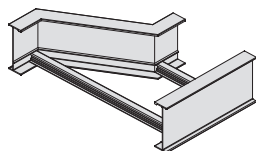

ACCESSORIES

Pages 143 - 144

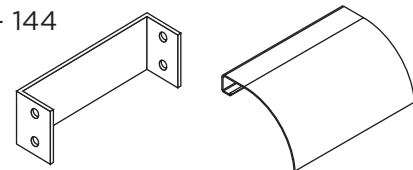

45° "Y" BRANCH

Page 131

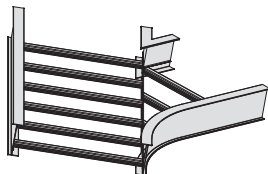

BARRIER STRIPS & ACCESSORIES

Page 145

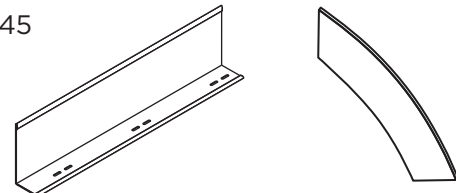

VERTICAL ELBOWS

Pages 132 - 135

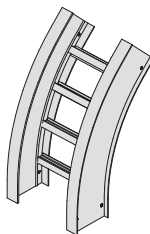

BRACKETS & HANGERS

Pages 146 - 148

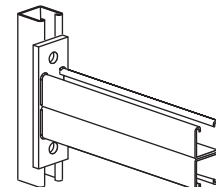

I-BEAM CABLE TRAY SYSTEM

ALUMINUM TRAY

SELECTION CHART

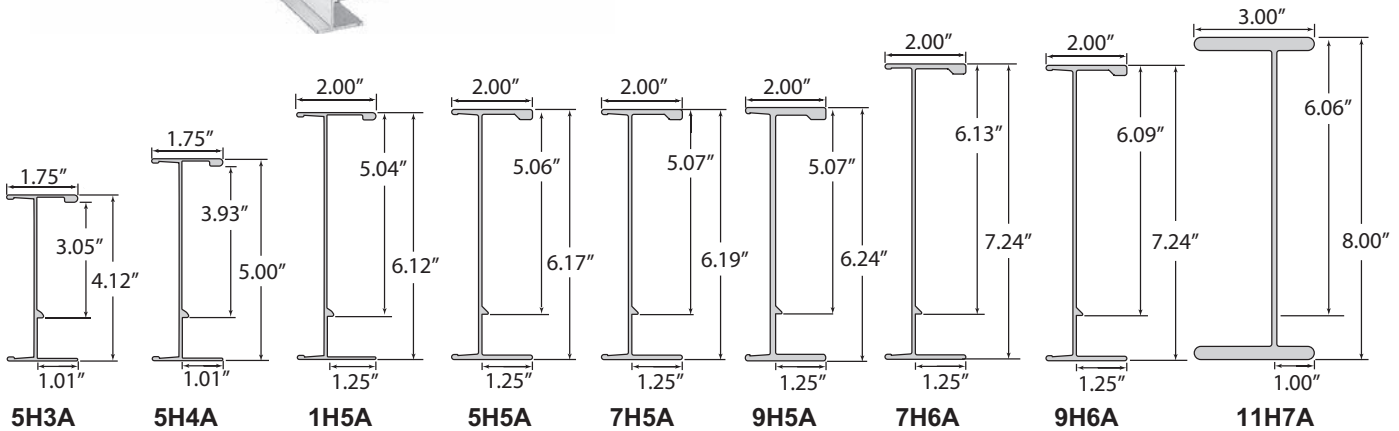
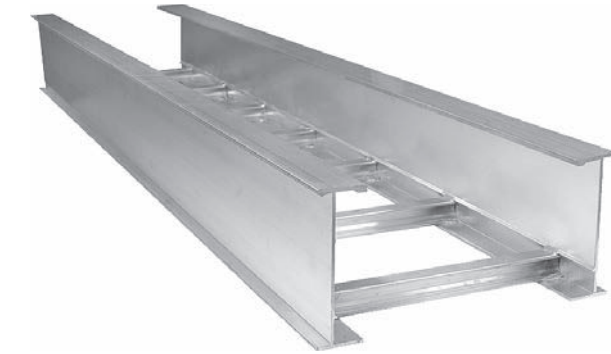

NEMA CLASS, PHYSICAL AND STRUCTURAL PROPERTIES

NEMA Standard VE-1 Load/Span Class	NEMA Ld/Span	Cope System Number	Actual Load Depth		Side Rail Height		Flange Width (in.)	Sect. Mod. of 2 Rails Sx (in.3)	Moment of Inertia for 2 Rails Ix (in.4)	Min X-Sect. Area of 2 Rails per NEC 392.7 (in.2)
12C	100 lb./ft. 12' span	5H3A	3.05"	(77mm)	4.12"	(105mm)	1-3/4	1.48	3.10	1.18
12C	100 lb./ft. 12' span	5H4A	3.93"	(100mm)	5"	(127mm)	1-3/4	1.93	4.90	1.30
16A	50 lb./ft. 16' span	5H3A	3.05"	(77mm)	4.12"	(105mm)	1-3/4	1.48	3.10	1.18
16A	50 lb./ft. 16' span	5H4A	3.93"	(100mm)	5"	(127mm)	1-3/4	1.93	4.90	1.30
16B	75 lb./ft. 16' span	1H5A	5.04"	(128mm)	6.12"	(155mm)	2	2.53	7.92	1.41
16C	100 lb./ft. 16' span	5H5A	5.06"	(129mm)	6.17"	(157mm)	2	3.36	10.85	1.81
20A	50 lb./ft. 20' span	1H5A	5.04"	(128mm)	6.12"	(155mm)	2	2.53	7.92	1.41
20B	75 lb./ft. 20' span	5H5A	5.06"	(129mm)	6.17"	(157mm)	2	3.36	10.85	1.81
20C	100 lb./ft. 20' span	7H5A	5.07"	(129mm)	6.19"	(157mm)	2	3.85	12.44	2.00
20C	100 lb./ft. 20' span	7H6A	6.13"	(156mm)	7.24"	(184mm)	2	4.94	17.88	2.38
20C+	100 lb./ft. 24' span	9H5A	5.07"	(129mm)	6.24"	(158mm)	2	5.34	17.52	2.00
20C+	100 lb./ft. 24' span	9H6A	6.09"	(155mm)	7.24"	(184mm)	2	6.10	22.91	3.04
30C	100 lb./ft. 30' span	11H7A	6.06"	(154mm)	8"	(203mm)	3	16.17	64.69	5.67

MATERIAL & FINISH SPECIFICATIONS (I-BEAM CABLE TRAY)

Item	Aluminum	Item	Aluminum
Siderails	AA-6063-T6 Extruded	Splice Plate Finish	AA-5052-H34
Rungs	AA-6063-T6 Extruded* AA-6063-T832 Extruded* AA-6063-T52 Extruded*	Connector Bolts	SAE J429 Grade 1 (ASTM A-307 Grade A)
Covers	AA-3003 H14 or 3150 H14	Bolt Plating	ASTM B-633.0002" Zinc

*Special High Strength 32 ksi Minimum Yield

**LOAD AND DEFLECTION DATA FOR ALUMINUM LADDER
WORKING (ALLOWABLE) LOAD CAPACITY, EVENLY DISTRIBUTED-TESTED PER NEMA STANDARD VE-1,
SIMPLE BEAM - SAFETY FACTOR 1.5**

Cope System No.	NEMA	CLASSIFIED UL	CLASSIFIED C UL	SA	SPAN											
					6 Ft			8 Ft			10 Ft			12 Ft		
					w	d	k	w	d	k	w	d	k	w	d	k
5H3A	16A & 12C	X			455	0.52	0.001	256	0.93	0.004	164	1.46	0.009	114	2.10	0.018
5H4A	16A & 12C	X			505	0.33	0.001	284	0.58	0.002	182	0.91	0.005	126	1.31	0.010
1H5A	16B & 20A	X	X		555	0.21	0.000	319	0.36	0.001	204	0.57	0.003	142	0.85	0.006
5H5A	16C & 20B	X	X		917	0.25	0.000	527	0.44	0.001	337	0.69	0.002	233	1.00	0.004
7H5A	20C	X	X	X	1,178	0.27	0.000	663	0.47	0.001	424	0.74	0.002	294	1.07	0.004
9H5A	20C+	X	X	X	1,889	0.32	0.000	1,063	0.57	0.001	680	0.89	0.001	472	1.28	0.003
7H6A	20C	X	X		1,105	0.18	0.000	622	0.32	0.001	398	0.50	0.001	276	0.72	0.003
9H6A	20C+	X	X		1,656	0.21	0.000	932	0.37	0.000	596	0.58	0.001	413	0.84	0.002

Cope System No.	NEMA	CLASSIFIED UL	CLASSIFIED C UL	SA	SPAN											
					16 Ft			20 Ft			24 Ft			25 Ft		
					w	d	k	w	d	k	w	d	k	w	d	k
5H3A	16A & 12C	X			64	3.73	0.058	-	-	-	-	-	-	-	-	-
5H4A	16A & 12C	X			71	2.33	0.033	-	-	-	-	-	-	-	-	-
1H5A	16B & 20A	X	X		80	1.52	0.019	51	2.30	0.045	-	-	-	-	-	-
5H5A	16C & 20B	X	X		131	1.83	0.014	84	2.77	0.033	-	-	-	-	-	-
7H5A	20C	X	X	X	166	1.89	0.011	106	2.96	0.028	73	4.20	0.058	-	-	-
9H5A	20C+	X	X	X	266	2.27	0.009	170	3.55	0.021	117	5.04	0.043	108	5.48	0.510
7H6A	20C	X	X		156	1.28	0.008	100	2.01	0.020	69	2.88	0.042	-	-	-
9H6A	20C+	X	X		233	1.49	0.006	149	2.38	0.016	103	3.40	0.033	95	3.61	0.038

Note: Contact your Cope representative for loading information on the 11H7A system
 To convert 1.5 safety factor to 2.0 multiply w, d, k by .75
 w = Pounds per linear foot
 d = Deflections (inches)
 k = Deflection (in.) for each pound of load
 t = Denotes k is less than .001 inch

I-BEAM CABLE TRAY SYSTEM

PART NUMBERING SYSTEM:

Please pay careful attention to the part numbering structure. Example: Catalog No. 5H4A-06SL-12-09 is a 4" load depth aluminum ladder with an I-Beam flange, 6 inches wide, straight length 12 feet long, rungs on 9" centers. Please make sure to use the system numbers from pages 66 and 67 when ordering.

STRAIGHT LENGTH

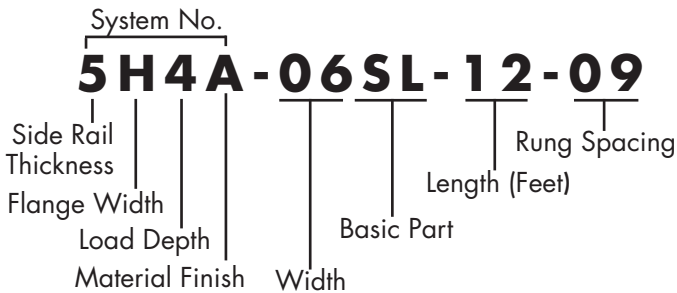

FITTINGS

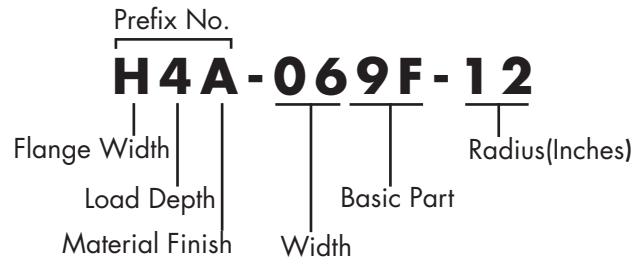

SYSTEM NUMBER (STRAIGHT SECTION ONLY) -

The first four digits make up the system number which identifies the structural, dimensional and material characteristics of the straight length. It is made up of the side rail digits indicating the side rail thickness and flange design, the load depth (inside, in inches) and material finish (aluminum).

- 1H5A:** 3 Thick, I-Beam Rail, 5" Load Depth, Aluminum
- 5H3A:** 5 Thick, I-Beam Rail, 3" Load Depth, Aluminum
- 5H4A:** 5 Thick, I-Beam Rail, 4" Load Depth, Aluminum
- 5H5A:** 5 Thick, I-Beam Rail, 5" Load Depth, Aluminum
- 7H5A:** 7 Thick, I-Beam Rail, 5" Load Depth, Aluminum
- 7H6A:** 7 Thick, I-Beam Rail, 6" Load Depth, Aluminum
- 9H5A:** 9 Thick, I-Beam Rail, 5" Load Depth, Aluminum
- 9H6A:** 9 Thick, I-Beam Rail, 6" Load Depth, Aluminum
- 11H7A:** 11 Thick, I-Beam Rail, 7" Load Depth, Aluminum

PREFIX NUMBER (FITTINGS ONLY) - Fittings are ordered using the 3-digit prefix number given in the charts on the fitting pages.

- H3A:** I-Beam Rail, 3" Load Depth, Aluminum
- H4A:** I-Beam Rail, 4" Load Depth, Aluminum
- H5A:** I-Beam Rail, 5" Load Depth, Aluminum
- H6A:** I-Beam Rail, 6" Load Depth, Aluminum
- H7A:** I-Beam Rail, 7" Load Depth, Aluminum

WIDTH - The inside width of the tray.

- 06:** 6" Width (152mm)
- 09:** 9" Width (229mm)
- 12:** 12" Width (305mm)
- 18:** 18" Width (457mm)
- 24:** 24" Width (610mm)
- 30:** 30" Width (762mm)
- 36:** 36" Width (914mm)

Length (STRAIGHT SECTION ONLY) - The length of the tray in feet.

- 12:** 12' Length (3.7m)
- 20:** 20' Length (6.1m)
- 24:** 24' Length (7.3m)
- 30:** 30' Length (9.1m)

BASIC PART NUMBER - Identifies the straight length, fitting, or accessory.

- SL:** Straight Length
- 9F:** 90° Horizontal Elbow
- 6F:** 60° Horizontal Elbow
- 4F:** 45° Horizontal Elbow
- 3F:** 30° Horizontal Elbow
- 9O:** 90° Vertical Outside Elbow
- 6O:** 60° Vertical Outside Elbow
- 4O:** 45° Vertical Outside Elbow
- 3O:** 30° Vertical Outside Elbow
- 9I:** 90° Vertical Inside Elbow
- 6I:** 60° Vertical Inside Elbow
- 4I:** 45° Vertical Inside Elbow
- 3I:** 30° Vertical Inside Elbow
- FT:** Horizontal Tee
- TT:** Horizontal Tapped Tee
- FC:** Horizontal Cross
- TC:** Horizontal Tapped Cross
- VT:** Vertical Tee
- SR:** Vertical Cable Support Elbow
- ST:** Straight Reducer
- RH:** Right Hand Reducer
- LH:** Left Hand Reducer
- RY:** 45°"Y" Right Hand Branch
- LY:** 45°"Y" Left Hand Branch

RUNG SPACING - The center-to-center distance between rungs on straight length. Rung spacing is maintained through centerline of all fittings.

- 09:** 9" Nominal (229mm) rung spacing

Radius (FITTINGS ONLY) - The radius of bend.

- 12:** 12" Length (305mm)
- 24:** 24" Length (610mm)
- 36:** 36" Length (914mm)

I-BEAM FITTINGS

Fittings are used to change the size or direction of the cable tray. A wide variety of standard fittings are offered to simplify installation of a tray system. Horizontal or vertical bends are offered for each tray width and with angles of 30°, 45°, 60° or 90°. The radius of the bend, whether horizontal or vertical, can be 12", 24", 36", or even greater on a custom basis. Specification of the radius of the bend involves a trade-off between available space, minimum bending radius of cables, ease of cable pulling, and cost. The most common radius is 24 in. Fittings are not subject to NEMA/CSA load ratings and the diagrams below illustrate how the tray should be supported near the fittings.

When a standard angle will not work, field fittings or adjustable elbows can be used. Refer to NEMA VE2 Installation Guidelines for suggested support locations for these situations.

Support for Flat Fittings

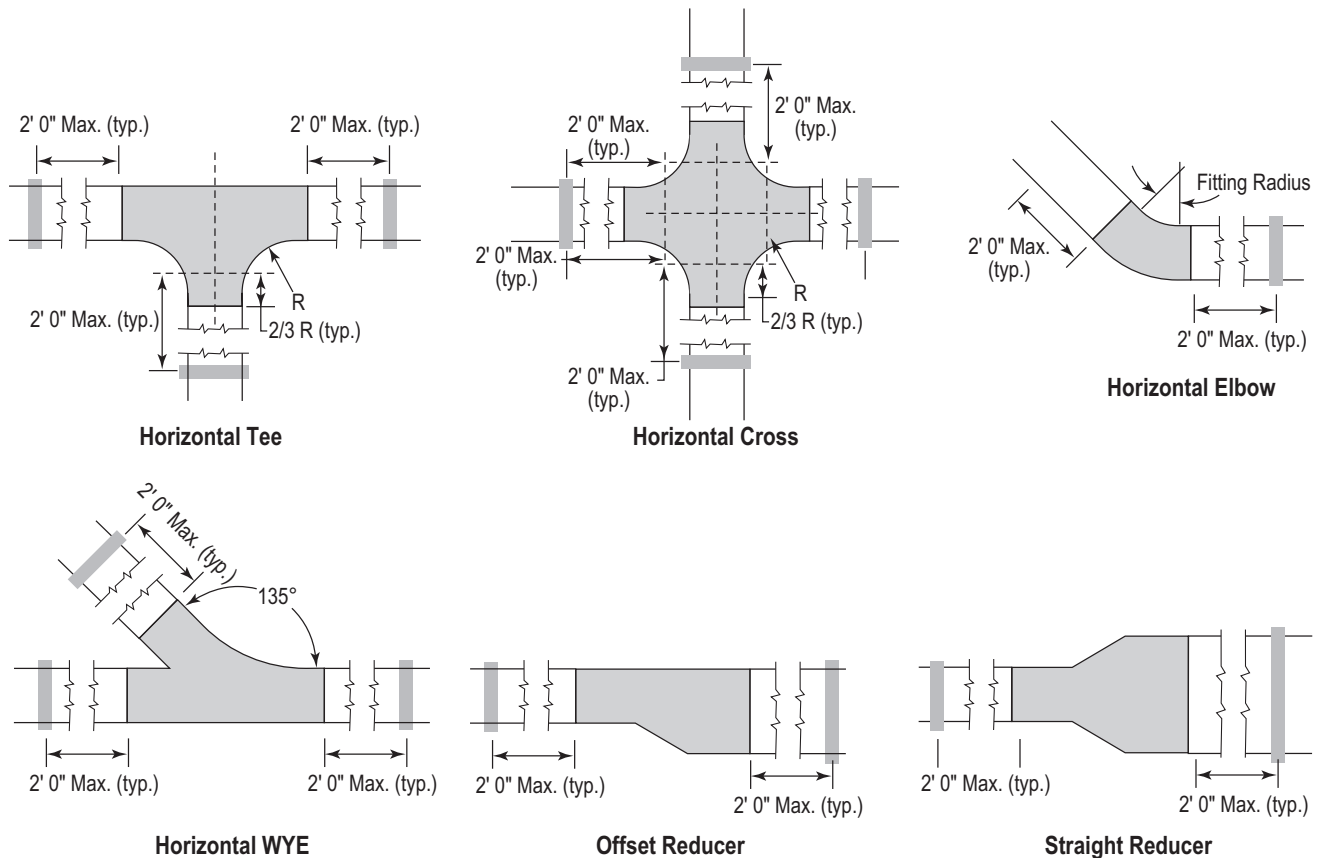

Support for Vertical Fittings

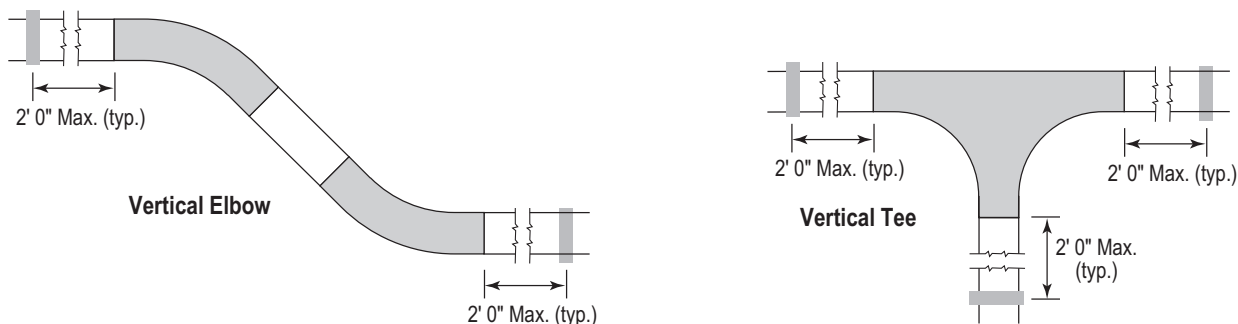

I-BEAM CABLE TRAY SYSTEM

90° HORIZONTAL ELBOW [9F]

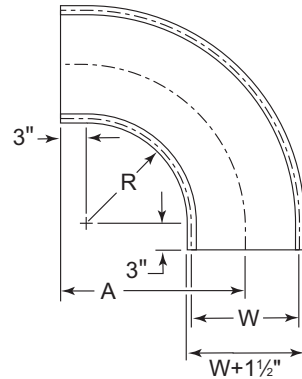
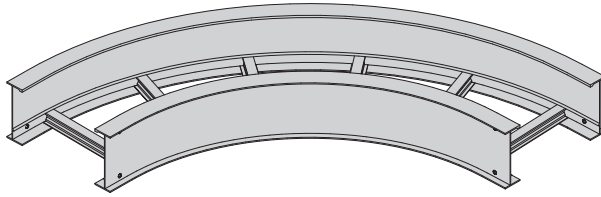

Radius - R	Width - W		"A" Dimension		Part Number
12" (305mm)	6"	(152mm)	18"	(457mm)	HDA-069F-12
	9"	(229mm)	19½"	(495mm)	HDA-099F-12
	12"	(305mm)	21"	(533mm)	HDA-129F-12
	18"	(457mm)	24"	(610mm)	HDA-189F-12
	24"	(610mm)	27"	(686mm)	HDA-249F-12
	30"	(762mm)	30"	(762mm)	HDA-309F-12
	36"	(914mm)	33"	(838mm)	HDA-369F-12
24" (610mm)	6"	(152mm)	30"	(762mm)	HDA-069F-24
	9"	(229mm)	31½"	(800mm)	HDA-099F-24
	12"	(305mm)	33"	(838mm)	HDA-129F-24
	18"	(457mm)	36"	(914mm)	HDA-189F-24
	24"	(610mm)	39"	(991mm)	HDA-249F-24
	30"	(762mm)	42"	(1067mm)	HDA-309F-24
	36"	(914mm)	45"	(1143mm)	HDA-369F-24
36" (914mm)	6"	(152mm)	42"	(1067mm)	HDA-069F-36
	9"	(229mm)	43½"	(1105mm)	HDA-099F-36
	12"	(305mm)	45"	(1143mm)	HDA-129F-36
	18"	(457mm)	48"	(1219mm)	HDA-189F-36
	24"	(610mm)	51"	(1295mm)	HDA-249F-36
	30"	(762mm)	54"	(1372mm)	HDA-309F-36
	36"	(914mm)	57"	(1448mm)	HDA-369F-36

Example: H4A-129F-12

Note: Nominal 9" rung spacing maintained through centerline of all fittings.

Note: Nominal 9" rung spacing maintained through centerline of all fittings.

Ordering Information:

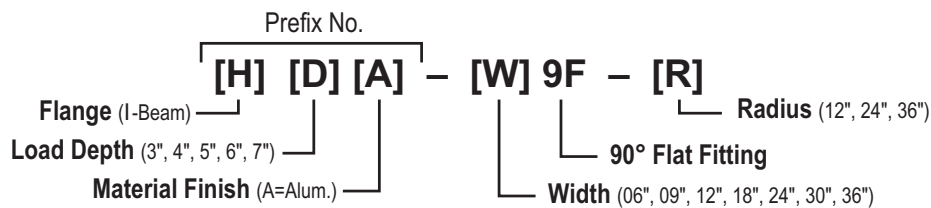

See Page 149
for Electrical
Grounding Chart

60° HORIZONTAL ELBOW [6F]

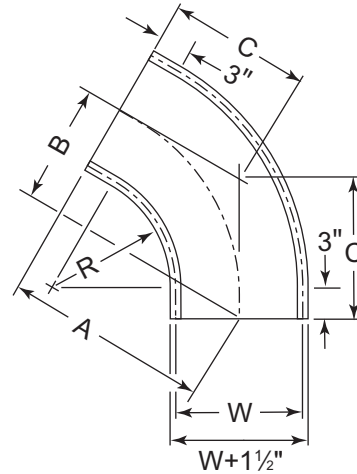
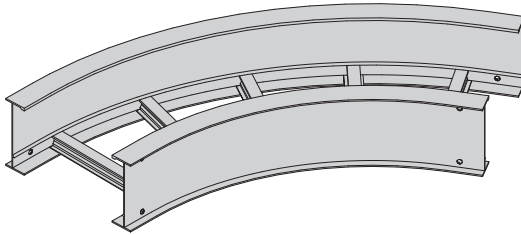

Radius - R	Width - W	"A" Dimension	"B" Dimension	"C" Dimension	Part Number
12" (305mm)	6" (152mm)	17½" (445mm)	10⅞" (257mm)	11⅜" (297mm)	HDA-066F-12
	9" (229mm)	18⅜" (478mm)	10⅞" (276mm)	12½" (318mm)	HDA-096F-12
	12" (305mm)	20⅞" (510mm)	11⅞" (295mm)	13⅞" (340mm)	HDA-126F-12
	18" (457mm)	22⅜" (576mm)	13⅞" (333mm)	15⅞" (384mm)	HDA-186F-12
	24" (610mm)	25⅞" (643mm)	14⅞" (371mm)	16⅞" (429mm)	HDA-246F-12
	30" (762mm)	27⅞" (708mm)	16⅞" (410mm)	18⅞" (471mm)	HDA-306F-12
24" (610mm)	6" (152mm)	27⅞" (708mm)	16⅞" (410mm)	18⅞" (471mm)	HDA-066F-24
	9" (229mm)	29⅞" (741mm)	16⅞" (429mm)	19⅞" (494mm)	HDA-096F-24
	12" (305mm)	30⅞" (775mm)	17⅞" (448mm)	20⅞" (516mm)	HDA-126F-24
	18" (457mm)	33⅞" (840mm)	19⅞" (486mm)	22⅞" (560mm)	HDA-186F-24
	24" (610mm)	35⅞" (906mm)	20⅞" (524mm)	23⅞" (605mm)	HDA-246F-24
	30" (762mm)	38⅞" (972mm)	22⅞" (562mm)	25⅞" (648mm)	HDA-306F-24
36" (914mm)	6" (152mm)	38⅞" (972mm)	22⅞" (562mm)	25⅞" (648mm)	HDA-066F-36
	9" (229mm)	39⅞" (1005mm)	22⅞" (581mm)	26⅞" (670mm)	HDA-096F-36
	12" (305mm)	40⅞" (1038mm)	23⅞" (600mm)	27⅞" (692mm)	HDA-126F-36
	18" (457mm)	43⅞" (1105mm)	25⅞" (638mm)	29" (737mm)	HDA-186F-36
	24" (610mm)	46⅞" (1170mm)	26⅞" (676mm)	30⅞" (779mm)	HDA-246F-36
	30" (762mm)	48⅞" (1237mm)	28⅞" (714mm)	32⅞" (824mm)	HDA-306F-36
36" (914mm)	51⅞" (1302mm)	29⅞" (752mm)	34⅞" (868mm)	HDA-366F-36	

Example: H4A-126F-12

Note: Nominal 9" rung spacing maintained through centerline of all fittings.

See Page 149
for Electrical
Grounding Chart

I-BEAM CABLE TRAY SYSTEM

45° HORIZONTAL ELBOW [4F]

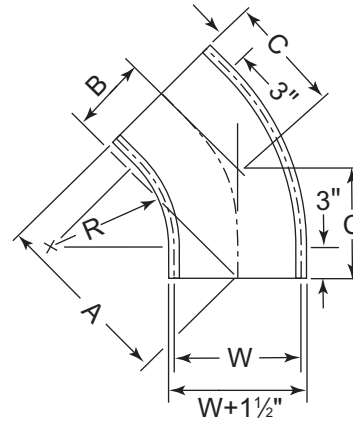
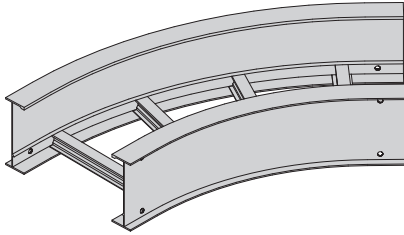

Radius - R	Width - W	"A" Dimension	"B" Dimension	"C" Dimension	Part Number
12" (305mm)	6" (152mm)	15 3/4" (400mm)	6 1/2" (165mm)	9 9/16" (233mm)	HDA-064F-12
	9" (229mm)	16 1 3/16" (427mm)	6 1 5/16" (176mm)	9 9/16" (249mm)	HDA-094F-12
	12" (305mm)	17 7/8" (454mm)	7 3/8" (187mm)	10 7/16" (265mm)	HDA-124F-12
	18" (457mm)	20" (508mm)	8 1/4" (210mm)	11 1 1/16" (297mm)	HDA-184F-12
	24" (610mm)	22 1/16" (560mm)	9 3/8" (232mm)	12 1 5/16" (329mm)	HDA-244F-12
	30" (762mm)	24 3/16" (614mm)	10" (254mm)	14 3/16" (360mm)	HDA-304F-12
36" (914mm)	26 5/16" (668mm)	10 1 5/16" (278mm)	15 5/16" (392mm)	HDA-364F-12	
24" (610mm)	6" (152mm)	24 3/16" (614mm)	10" (254mm)	14 3/16" (360mm)	HDA-064F-24
	9" (229mm)	25 1/4" (641mm)	10 1/2" (267mm)	14 1 3/16" (376mm)	HDA-094F-24
	12" (305mm)	26 5/16" (668mm)	10 5/16" (278mm)	15 7/16" (392mm)	HDA-124F-24
	18" (457mm)	28 7/16" (722mm)	11 1 3/16" (300mm)	16 1 1/16" (424mm)	HDA-184F-24
	24" (610mm)	30 9/16" (776mm)	12 1 1/16" (322mm)	17 1 5/16" (456mm)	HDA-244F-24
	30" (762mm)	32 1 1/16" (830mm)	13 3/16" (344mm)	19 9/16" (486mm)	HDA-304F-24
36" (914mm)	34 1 3/16" (884mm)	14 1/16" (367mm)	20 3/8" (518mm)	HDA-364F-24	
36" (914mm)	6" (152mm)	32 1 1/16" (830mm)	13 3/16" (344mm)	19 9/16" (486mm)	HDA-064F-36
	9" (229mm)	33 3/4" (857mm)	14" (356mm)	19 3/4" (502mm)	HDA-094F-36
	12" (305mm)	34 1 3/16" (884mm)	14 7/16" (367mm)	20 3/8" (518mm)	HDA-124F-36
	18" (457mm)	36 1 5/16" (938mm)	15 5/16" (389mm)	21 1/8" (549mm)	HDA-184F-36
	24" (610mm)	39 1/16" (992mm)	16 3/16" (411mm)	22 7/8" (581mm)	HDA-244F-36
	30" (762mm)	41 3/16" (1046mm)	17 1/16" (433mm)	24 1/8" (613mm)	HDA-304F-36
36" (914mm)	43 5/16" (1100mm)	17 1 5/16" (456mm)	25 5/8" (645mm)	HDA-364F-36	

Example: H4A-124F-12

Note: Nominal 9" rung spacing maintained through centerline of all fittings.

See Page 149
for Electrical
Grounding Chart

30° HORIZONTAL ELBOW [3F]

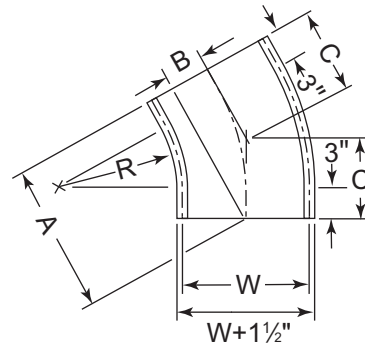
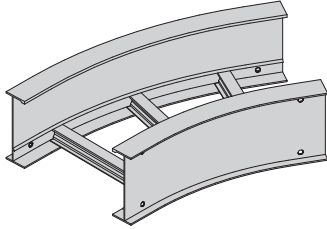

Radius - R	Width - W	"A" Dimension	"B" Dimension	"C" Dimension	Part Number
12" (305mm)	6" (152mm)	13 ¹ / ₈ " (333mm)	3 ¹ / ₂ " (89mm)	7" (178mm)	HDA-063F-12
	9" (229mm)	13 ³ / ₈ " (352mm)	3 ¹ / ₁₆ " (94mm)	7 ⁷ / ₁₆ " (189mm)	HDA-093F-12
	12" (305mm)	14 ⁵ / ₈ " (371mm)	3 ³ / ₁₆ " (100mm)	7 ⁹ / ₁₆ " (198mm)	HDA-123F-12
	18" (457mm)	16 ¹ / ₈ " (410mm)	4 ¹ / ₁₆ " (110mm)	8 ¹ / ₁₆ " (219mm)	HDA-183F-12
	24" (610mm)	17 ³ / ₈ " (448mm)	4 ¹ / ₁₆ " (119mm)	9 ⁷ / ₁₆ " (240mm)	HDA-243F-12
	30" (762mm)	19 ¹ / ₈ " (486mm)	5 ¹ / ₈ " (130mm)	10 ¹ / ₄ " (260mm)	HDA-303F-12
	36" (914mm)	20 ³ / ₈ " (524mm)	5 ¹ / ₂ " (140mm)	11 ¹ / ₁₆ " (281mm)	HDA-363F-12
24" (610mm)	6" (152mm)	19 ¹ / ₈ " (486mm)	5 ¹ / ₈ " (130mm)	10 ¹ / ₄ " (260mm)	HDA-063F-24
	9" (229mm)	19 ³ / ₈ " (505mm)	5 ⁵ / ₁₆ " (135mm)	10 ⁵ / ₈ " (270mm)	HDA-093F-24
	12" (305mm)	20 ³ / ₈ " (524mm)	5 ¹ / ₂ " (140mm)	11 ¹ / ₁₆ " (281mm)	HDA-123F-24
	18" (457mm)	22 ¹ / ₈ " (562mm)	5 ⁹ / ₁₆ " (151mm)	11 ¹ / ₈ " (300mm)	HDA-183F-24
	24" (610mm)	23 ³ / ₈ " (600mm)	6 ³ / ₁₆ " (160mm)	12 ³ / ₈ " (321mm)	HDA-243F-24
	30" (762mm)	25 ¹ / ₈ " (638mm)	6 ³ / ₄ " (171mm)	13 ³ / ₈ " (341mm)	HDA-303F-24
36" (914mm)	6" (152mm)	25 ¹ / ₈ " (638mm)	6 ³ / ₄ " (171mm)	13 ³ / ₁₆ " (341mm)	HDA-063F-36
	9" (229mm)	25 ³ / ₈ " (657mm)	6 ⁵ / ₁₆ " (176mm)	13 ³ / ₈ " (352mm)	HDA-093F-36
	12" (305mm)	26 ⁵ / ₈ " (676mm)	7 ¹ / ₈ " (181mm)	14 ¹ / ₄ " (362mm)	HDA-123F-36
	18" (457mm)	28 ¹ / ₈ " (714mm)	7 ¹ / ₂ " (191mm)	15 ¹ / ₁₆ " (383mm)	HDA-183F-36
	24" (610mm)	29 ³ / ₈ " (752mm)	7 ⁹ / ₁₆ " (202mm)	15 ⁵ / ₈ " (403mm)	HDA-243F-36
	30" (762mm)	31 ¹ / ₈ " (791mm)	8 ³ / ₁₆ " (211mm)	16 ¹ / ₁₆ " (424mm)	HDA-303F-36
	36" (914mm)	32 ³ / ₈ " (829mm)	8 ³ / ₄ " (222mm)	17 ¹ / ₂ " (445mm)	HDA-363F-36

Example: H4A-123F-12

Note: Nominal 9" rung spacing maintained through centerline of all fittings.

See Page 149
for Electrical
Grounding Chart

I-BEAM CABLE TRAY SYSTEM

HORIZONTAL TEE [FT]

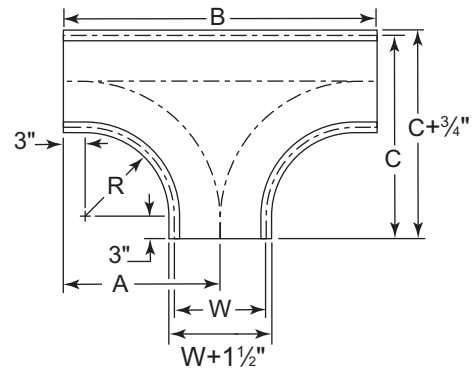
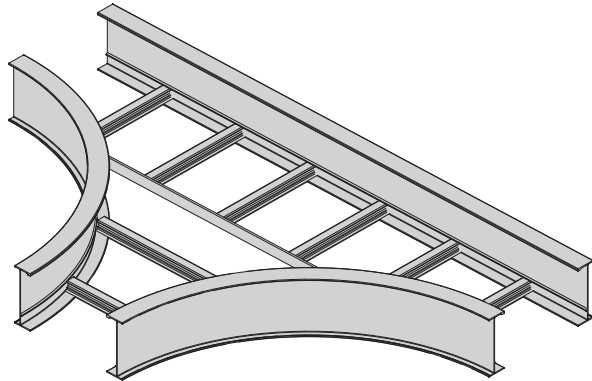

Radius - R	Width - W	"A" Dimension	"B" Dimension	"C" Dimension	Part Number
12" (305mm)	6" (152mm)	18" (457mm)	36" (914mm)	21" (533mm)	HDA-06FT-12
	9" (229mm)	19½" (495mm)	39" (991mm)	24" (610mm)	HDA-09FT-12
	12" (305mm)	21" (533mm)	42" (1067mm)	27" (686mm)	HDA-12FT-12
	18" (457mm)	24" (610mm)	48" (1219mm)	33" (838mm)	HDA-18FT-12
	24" (610mm)	27" (686mm)	54" (1372mm)	39" (991mm)	HDA-24FT-12
	30" (762mm)	30" (762mm)	60" (1524mm)	45" (1143mm)	HDA-30FT-12
24" (610mm)	6" (152mm)	30" (762mm)	60" (1524mm)	33" (838mm)	HDA-06FT-24
	9" (229mm)	31½" (800mm)	63" (1600mm)	36" (914mm)	HDA-09FT-24
	12" (305mm)	33" (838mm)	66" (1676mm)	39" (991mm)	HDA-12FT-24
	18" (457mm)	36" (914mm)	72" (1829mm)	45" (1143mm)	HDA-18FT-24
	24" (610mm)	39" (991mm)	78" (1981mm)	51" (1295mm)	HDA-24FT-24
	30" (762mm)	42" (1067mm)	84" (2134mm)	57" (1448mm)	HDA-30FT-24
36" (914mm)	6" (152mm)	42" (1067mm)	84" (2134mm)	45" (1143mm)	HDA-06FT-36
	9" (229mm)	43½" (1105mm)	87" (2210mm)	48" (1219mm)	HDA-09FT-36
	12" (305mm)	45" (1143mm)	90" (2286mm)	51" (1295mm)	HDA-12FT-36
	18" (457mm)	48" (1219mm)	96" (2438mm)	57" (1448mm)	HDA-18FT-36
	24" (610mm)	51" (1295mm)	102" (2591mm)	63" (1600mm)	HDA-24FT-36
	30" (762mm)	54" (1372mm)	108" (2743mm)	69" (1753mm)	HDA-30FT-36
36" (914mm)	57" (1448mm)	114" (2896mm)	75" (1905mm)	HDA-36FT-36	

Example: H4A-12FT-12

Note: Nominal 9" rung spacing maintained through centerline of all fittings.

See Page 149
for Electrical
Grounding Chart

HORIZONTAL TAPPED TEE [TT]

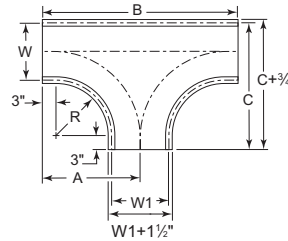
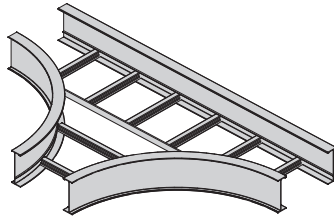

See Page 149
for Electrical
Grounding Chart

Radius - R	Width - W	Width - W1	"A"	"C" Dimension	Part Number	
12" (305mm)	36" (914mm)	30" (762mm)	27" (686mm)	48" (1219mm)	HDA-36TT-30-12	
		24" (610mm)	24" (610mm)	48" (1219mm)	HDA-36TT-24-12	
		18" (457mm)	21" (533mm)	48" (1219mm)	HDA-36TT-18-12	
		12" (305mm)	18" (457mm)	48" (1219mm)	HDA-36TT-12-12	
		9" (229mm)	16½" (419mm)	48" (1219mm)	HDA-36TT-09-12	
	30" (762mm)	24" (610mm)	24" (610mm)	42" (1067mm)	HDA-30TT-24-12	
		18" (457mm)	21" (533mm)	42" (1067mm)	HDA-30TT-18-12	
		12" (305mm)	18" (457mm)	42" (1067mm)	HDA-30TT-12-12	
		9" (229mm)	16½" (419mm)	42" (1067mm)	HDA-30TT-09-12	
		6" (152mm)	15" (381mm)	42" (1067mm)	HDA-30TT-06-12	
	24" (610mm)	18" (457mm)	21" (533mm)	36" (914mm)	HDA-24TT-18-12	
		12" (305mm)	18" (457mm)	36" (914mm)	HDA-24TT-12-12	
		9" (229mm)	16½" (419mm)	36" (914mm)	HDA-24TT-09-12	
		6" (152mm)	15" (381mm)	36" (914mm)	HDA-24TT-06-12	
		18" (457mm)	12" (305mm)	18" (457mm)	30" (762mm)	HDA-18TT-12-12
	9" (229mm)		16½" (419mm)	30" (762mm)	HDA-18TT-09-12	
	6" (152mm)		15" (381mm)	30" (762mm)	HDA-18TT-06-12	
	12" (305mm)		9" (229mm)	16½" (419mm)	24" (610mm)	HDA-12TT-09-12
			6" (152mm)	15" (381mm)	24" (610mm)	HDA-12TT-06-12
		9" (229mm)	6" (152mm)	15" (381mm)	21" (533mm)	HDA-09TT-06-12
36" (914mm)			30" (762mm)	39" (991mm)	60" (1524mm)	HDA-36TT-30-24
			24" (610mm)	36" (914mm)	60" (1524mm)	HDA-36TT-24-24
	18" (457mm)		33" (838mm)	60" (1524mm)	HDA-36TT-18-24	
	12" (305mm)		30" (762mm)	60" (1524mm)	HDA-36TT-12-24	
	9" (229mm)	28½" (724mm)	60" (1524mm)	HDA-36TT-09-24		
30" (762mm)	24" (610mm)	27" (686mm)	60" (1524mm)	HDA-36TT-06-24		
	18" (457mm)	24" (610mm)	54" (1372mm)	HDA-30TT-24-24		
	12" (305mm)	21" (533mm)	54" (1372mm)	HDA-30TT-18-24		
	9" (229mm)	18" (457mm)	54" (1372mm)	HDA-30TT-12-24		
	6" (152mm)	16½" (419mm)	54" (1372mm)	HDA-30TT-09-24		
24" (610mm)	18" (457mm)	15" (381mm)	54" (1372mm)	HDA-30TT-06-24		
	12" (305mm)	12" (305mm)	48" (1219mm)	HDA-24TT-18-24		
	9" (229mm)	10" (254mm)	48" (1219mm)	HDA-24TT-12-24		
	6" (152mm)	9" (229mm)	48" (1219mm)	HDA-24TT-09-24		
	18" (457mm)	8" (203mm)	48" (1219mm)	HDA-24TT-06-24		
12" (305mm)	12" (305mm)	10" (254mm)	42" (1067mm)	HDA-18TT-12-24		
	9" (229mm)	9" (229mm)	42" (1067mm)	HDA-18TT-09-24		
	6" (152mm)	8" (203mm)	42" (1067mm)	HDA-18TT-06-24		
	9" (229mm)	9" (229mm)	8" (203mm)	36" (914mm)	HDA-12TT-09-24	
		6" (152mm)	7" (178mm)	36" (914mm)	HDA-12TT-06-24	
36" (914mm)		30" (762mm)	27" (686mm)	33" (838mm)	HDA-09TT-06-24	
		24" (610mm)	24" (610mm)	72" (1829mm)	HDA-36TT-30-36	
		18" (457mm)	21" (533mm)	72" (1829mm)	HDA-36TT-24-36	
	12" (305mm)	18" (457mm)	72" (1829mm)	HDA-36TT-18-36		
	9" (229mm)	16½" (419mm)	72" (1829mm)	HDA-36TT-12-36		
30" (762mm)	24" (610mm)	15" (381mm)	72" (1829mm)	HDA-36TT-09-36		
	18" (457mm)	12" (305mm)	66" (1676mm)	HDA-30TT-24-36		
	12" (305mm)	10" (254mm)	66" (1676mm)	HDA-30TT-18-36		
	9" (229mm)	9" (229mm)	66" (1676mm)	HDA-30TT-12-36		
	6" (152mm)	8" (203mm)	66" (1676mm)	HDA-30TT-09-36		
24" (610mm)	18" (457mm)	7" (178mm)	66" (1676mm)	HDA-30TT-06-36		
	12" (305mm)	6" (152mm)	60" (1524mm)	HDA-24TT-18-36		
	9" (229mm)	5" (127mm)	60" (1524mm)	HDA-24TT-12-36		
	6" (152mm)	4" (102mm)	60" (1524mm)	HDA-24TT-09-36		
	18" (457mm)	3" (76mm)	60" (1524mm)	HDA-24TT-06-36		
12" (305mm)	12" (305mm)	3" (76mm)	54" (1372mm)	HDA-18TT-12-36		
	9" (229mm)	2" (51mm)	54" (1372mm)	HDA-18TT-09-36		
	6" (152mm)	1" (25mm)	54" (1372mm)	HDA-18TT-06-36		
	9" (229mm)	9" (229mm)	1" (25mm)	48" (1219mm)	HDA-12TT-09-36	
		6" (152mm)	1" (25mm)	48" (1219mm)	HDA-12TT-06-36	
36" (914mm)		30" (762mm)	1" (25mm)	45" (1143mm)	HDA-09TT-06-36	

Note: Nominal 9" rung spacing maintained through centerline of all fittings.

I-BEAM CABLE TRAY SYSTEM

HORIZONTAL CROSS [FC]

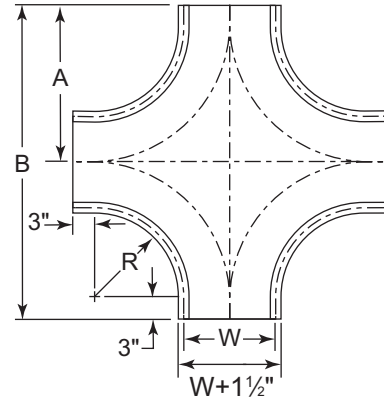
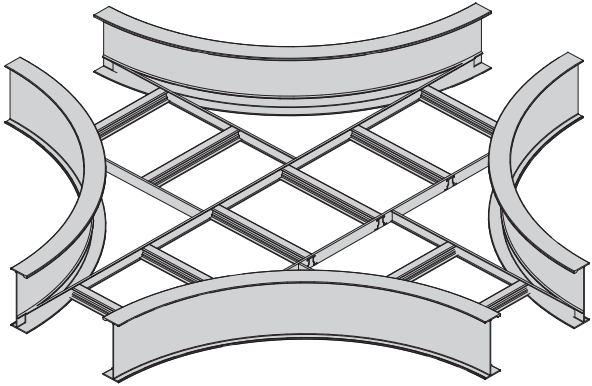

Radius - R	Width - W		"A" Dimension		"B" Dimension		Part Number
12" (305mm)	6"	(152mm)	18"	(457mm)	36"	(914mm)	HDA-06FC-12
	9"	(229mm)	19½"	(495mm)	39"	(991mm)	HDA-09FC-12
	12"	(305mm)	21"	(533mm)	42"	(1067mm)	HDA-12FC-12
	18"	(457mm)	24"	(610mm)	48"	(1219mm)	HDA-18FC-12
	24"	(610mm)	27"	(686mm)	54"	(1372mm)	HDA-24FC-12
	30"	(762mm)	30"	(762mm)	60"	(1524mm)	HDA-30FC-12
24" (610mm)	6"	(152mm)	30"	(762mm)	60"	(1524mm)	HDA-06FC-24
	9"	(229mm)	31½"	(800mm)	63"	(1600mm)	HDA-09FC-24
	12"	(305mm)	33"	(838mm)	66"	(1676mm)	HDA-12FC-24
	18"	(457mm)	36"	(914mm)	72"	(1829mm)	HDA-18FC-24
	24"	(610mm)	39"	(991mm)	78"	(1981mm)	HDA-24FC-24
	30"	(762mm)	42"	(1067mm)	84"	(2134mm)	HDA-30FC-24
36" (914mm)	6"	(152mm)	42"	(1067mm)	84"	(2134mm)	HDA-06FC-36
	9"	(229mm)	43½"	(1105mm)	87"	(2210mm)	HDA-09FC-36
	12"	(305mm)	45"	(1143mm)	90"	(2286mm)	HDA-12FC-36
	18"	(457mm)	48"	(1219mm)	96"	(2438mm)	HDA-18FC-36
	24"	(610mm)	51"	(1295mm)	102"	(2591mm)	HDA-24FC-36
	30"	(762mm)	54"	(1372mm)	108"	(2743mm)	HDA-30FC-36
	36"	(914mm)	57"	(1448mm)	114"	(2896mm)	HDA-36FC-36

Example: H4A-12FC-12

Note: Nominal 9" rung spacing maintained through centerline of all fittings.

See Page 149
for Electrical
Grounding Chart

HORIZONTAL TAPPED CROSS [TC]

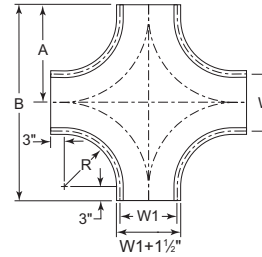
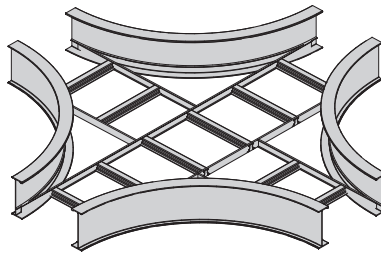

See Page 149
for Electrical
Grounding Chart

Radius - R	Width - W	Width - W1	"A" Dimension	"C" Dimension	Part Number			
12" (305mm)	36" (914mm)	30" (762mm)	27" (686mm)	60" (1524mm)	HDA-36TC-30-12			
		24" (610mm)	24" (610mm)	60" (1524mm)	HDA-36TC-24-12			
		18" (457mm)	21" (533mm)	60" (1524mm)	HDA-36TC-18-12			
		12" (305mm)	18" (457mm)	60" (1524mm)	HDA-36TC-12-12			
		9" (229mm)	16½" (419mm)	60" (1524mm)	HDA-36TC-09-12			
		6" (152mm)	15" (381mm)	60" (1524mm)	HDA-36TC-06-12			
		30" (762mm)	24" (610mm)	24" (610mm)	54" (1372mm)	HDA-30TC-24-12		
			18" (457mm)	21" (533mm)	54" (1372mm)	HDA-30TC-18-12		
	12" (305mm)		18" (457mm)	54" (1372mm)	HDA-30TC-12-12			
	9" (229mm)		16½" (419mm)	54" (1372mm)	HDA-30TC-09-12			
	6" (152mm)		15" (381mm)	54" (1372mm)	HDA-30TC-06-12			
	24" (610mm)		18" (457mm)	21" (533mm)	48" (1219mm)	HDA-24TC-18-12		
			12" (305mm)	18" (457mm)	48" (1219mm)	HDA-24TC-12-12		
			9" (229mm)	16½" (419mm)	48" (1219mm)	HDA-24TC-09-12		
		6" (152mm)	15" (381mm)	48" (1219mm)	HDA-24TC-06-12			
		18" (457mm)	12" (305mm)	18" (457mm)	42" (1067mm)	HDA-18TC-12-12		
			9" (229mm)	16½" (419mm)	42" (1067mm)	HDA-18TC-09-12		
			6" (152mm)	15" (381mm)	42" (1067mm)	HDA-18TC-06-12		
			12" (305mm)	9" (229mm)	16½" (419mm)	36" (914mm)	HDA-12TC-09-12	
	6" (152mm)			15" (381mm)	36" (914mm)	HDA-12TC-06-12		
	9" (229mm)			6" (152mm)	15" (381mm)	33" (838mm)	HDA-09TC-06-12	
				24" (610mm)	30" (762mm)	39" (991mm)	84" (2134mm)	HDA-36TC-30-24
					24" (610mm)	36" (914mm)	84" (2134mm)	HDA-36TC-24-24
		18" (457mm)			33" (838mm)	84" (2134mm)	HDA-36TC-18-24	
		12" (305mm)			30" (762mm)	84" (2134mm)	HDA-36TC-12-24	
		9" (229mm)			28½" (724mm)	84" (2134mm)	HDA-36TC-09-24	
		6" (152mm)	27" (686mm)		84" (2134mm)	HDA-36TC-06-24		
		30" (762mm)	24" (610mm)		36" (914mm)	78" (1981mm)	HDA-30TC-24-24	
18" (457mm)	33" (838mm)		78" (1981mm)		HDA-30TC-18-24			
12" (305mm)	30" (762mm)		78" (1981mm)	HDA-30TC-12-24				
9" (229mm)	28½" (724mm)		78" (1981mm)	HDA-30TC-09-24				
6" (152mm)	27" (686mm)		78" (1981mm)	HDA-30TC-06-24				
24" (610mm)	18" (457mm)		33" (838mm)	72" (1829mm)	HDA-24TC-18-24			
	12" (305mm)		30" (762mm)	72" (1829mm)	HDA-24TC-12-24			
	9" (229mm)		28½" (724mm)	72" (1829mm)	HDA-24TC-09-24			
	6" (152mm)	27" (686mm)	72" (1829mm)	HDA-24TC-06-24				
	18" (457mm)	12" (305mm)	30" (762mm)	66" (1676mm)	HDA-18TC-12-24			
		9" (229mm)	28½" (724mm)	66" (1676mm)	HDA-18TC-09-24			
		6" (152mm)	27" (686mm)	66" (1676mm)	HDA-18TC-06-24			
		12" (305mm)	9" (229mm)	28½" (724mm)	60" (1524mm)	HDA-12TC-09-24		
6" (152mm)			27" (686mm)	60" (1524mm)	HDA-12TC-06-24			
9" (229mm)			6" (152mm)	27" (686mm)	57" (1448mm)	HDA-09TC-06-24		
			36" (914mm)	30" (762mm)	51" (1295mm)	108" (2743mm)	HDA-36TC-30-36	
				24" (610mm)	48" (1219mm)	108" (2743mm)	HDA-36TC-24-36	
	18" (457mm)			45" (1143mm)	108" (2743mm)	HDA-36TC-18-36		
	12" (305mm)			42" (1067mm)	108" (2743mm)	HDA-36TC-12-36		
	9" (229mm)			40½" (1029mm)	108" (2743mm)	HDA-36TC-09-36		
	6" (152mm)	39" (991mm)		108" (2743mm)	HDA-36TC-06-36			
	30" (762mm)	24" (610mm)		48" (1219mm)	102" (2591mm)	HDA-30TC-24-36		
18" (457mm)		45" (1143mm)		102" (2591mm)	HDA-30TC-18-36			
12" (305mm)		42" (1067mm)	102" (2591mm)	HDA-30TC-12-36				
9" (229mm)		40½" (1029mm)	102" (2591mm)	HDA-30TC-09-36				
6" (152mm)		39" (991mm)	102" (2591mm)	HDA-30TC-06-36				
24" (610mm)		18" (457mm)	45" (1143mm)	96" (2438mm)	HDA-24TC-18-36			
		12" (305mm)	42" (1067mm)	96" (2438mm)	HDA-24TC-12-36			
		9" (229mm)	40½" (1029mm)	96" (2438mm)	HDA-24TC-09-36			
	6" (152mm)	39" (991mm)	96" (2438mm)	HDA-24TC-06-36				
	18" (457mm)	12" (305mm)	42" (1067mm)	90" (2286mm)	HDA-18TC-12-36			
		9" (229mm)	40½" (1029mm)	90" (2286mm)	HDA-18TC-09-36			
		6" (152mm)	39" (991mm)	90" (2286mm)	HDA-18TC-06-36			
		12" (305mm)	9" (229mm)	40½" (1029mm)	84" (2134mm)	HDA-12TC-09-36		
6" (152mm)			39" (991mm)	84" (2134mm)	HDA-12TC-06-36			
9" (229mm)			6" (152mm)	39" (991mm)	81" (2057mm)	HDA-09TC-06-36		

I-BEAM CABLE TRAY SYSTEM

LEFT HAND [LH] & RIGHT HAND [RH] REDUCER

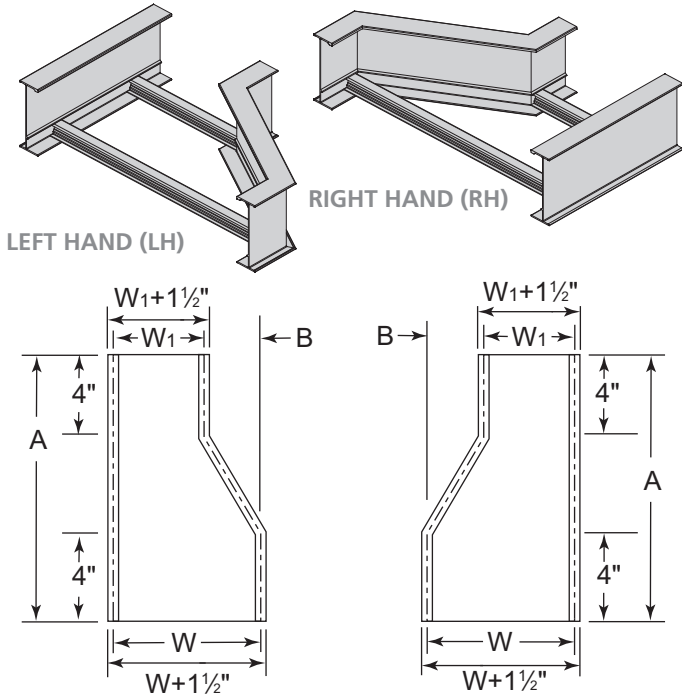

Straight Reducer [ST]

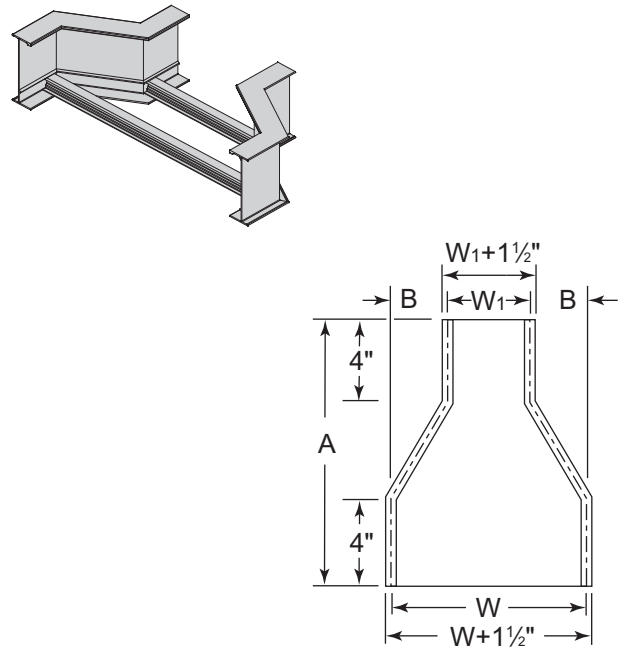

LEFT HAND [LH] & RIGHT HAND [RH] REDUCER

W	W1	"A" Dimension	"B" Dimension	Part Number
9" (229mm)	6" (152mm)	9 ³ / ₁₆ " (248mm)	3" (76mm)	HDA-09(LH/RH)-06
12" (305mm)	6" (152mm)	11 ¹ / ₁₆ " (291mm)	6" (152mm)	HDA-12(LH/RH)-06
	9" (229mm)	9 ³ / ₁₆ " (248mm)	3" (76mm)	HDA-12(LH/RH)-09
18" (457mm)	6" (152mm)	14 ¹ / ₁₆ " (379mm)	12" (305mm)	HDA-18(LH/RH)-06
	9" (229mm)	13 ³ / ₁₆ " (335mm)	9" (229mm)	HDA-18(LH/RH)-09
	12" (305mm)	11 ¹ / ₁₆ " (291mm)	6" (152mm)	HDA-18(LH/RH)-12
24" (610mm)	6" (152mm)	18 ³ / ₁₆ " (467mm)	18" (457mm)	HDA-24(LH/RH)-06
	9" (229mm)	16 ¹ / ₁₆ " (424mm)	15" (381mm)	HDA-24(LH/RH)-09
	12" (305mm)	14 ¹ / ₁₆ " (379mm)	12" (305mm)	HDA-24(LH/RH)-12
	18" (457mm)	11 ¹ / ₁₆ " (291mm)	6" (152mm)	HDA-24(LH/RH)-18
30" (762mm)	6" (152mm)	21 ¹ / ₁₆ " (556mm)	24" (610mm)	HDA-30(LH/RH)-06
	9" (229mm)	20 ¹ / ₁₆ " (511mm)	21" (533mm)	HDA-30(LH/RH)-09
	12" (305mm)	18 ³ / ₁₆ " (467mm)	18" (457mm)	HDA-30(LH/RH)-12
	18" (457mm)	14 ¹ / ₁₆ " (379mm)	12" (305mm)	HDA-30(LH/RH)-18
	24" (610mm)	11 ¹ / ₁₆ " (291mm)	6" (152mm)	HDA-30(LH/RH)-24
36" (914mm)	6" (152mm)	25 ¹ / ₁₆ " (643mm)	30" (762mm)	HDA-36(LH/RH)-06
	9" (229mm)	23 ³ / ₁₆ " (598mm)	27" (686mm)	HDA-36(LH/RH)-09
	12" (305mm)	21 ¹ / ₈ " (556mm)	24" (610mm)	HDA-36(LH/RH)-12
	18" (457mm)	18 ³ / ₁₆ " (467mm)	18" (457mm)	HDA-36(LH/RH)-18
	24" (610mm)	14 ¹ / ₁₆ " (379mm)	12" (305mm)	HDA-36(LH/RH)-24
	30" (762mm)	11 ¹ / ₁₆ " (291mm)	6" (152mm)	HDA-36(LH/RH)-30

STRAIGHT REDUCER [ST]

W	W1	"A" Dimension	"B" Dimension	Part Number
9" (229mm)	6" (152mm)	8 ⁷ / ₁₆ " (225mm)	1 ¹ / ₂ " (38mm)	HDA-09ST-06
12" (305mm)	6" (152mm)	9 ³ / ₁₆ " (248mm)	3" (76mm)	HDA-12ST-06
	9" (229mm)	8 ⁷ / ₁₆ " (225mm)	1 ¹ / ₂ " (38mm)	HDA-12ST-09
18" (457mm)	6" (152mm)	11 ¹ / ₁₆ " (291mm)	6" (152mm)	HDA-18ST-06
	9" (229mm)	10 ⁵ / ₁₆ " (270mm)	4 ¹ / ₂ " (114mm)	HDA-18ST-09
	12" (305mm)	9 ³ / ₁₆ " (248mm)	3" (76mm)	HDA-18ST-12
24" (610mm)	6" (152mm)	13 ³ / ₁₆ " (335mm)	9" (229mm)	HDA-24ST-06
	9" (229mm)	12 ⁵ / ₁₆ " (313mm)	7 ¹ / ₂ " (191mm)	HDA-24ST-09
	12" (305mm)	11 ¹ / ₁₆ " (291mm)	6" (152mm)	HDA-24ST-12
	18" (457mm)	9 ³ / ₁₆ " (248mm)	3" (76mm)	HDA-24ST-18
30" (762mm)	6" (152mm)	14 ¹ / ₁₆ " (379mm)	12" (305mm)	HDA-30ST-06
	9" (229mm)	14 ¹ / ₁₆ " (357mm)	10 ¹ / ₂ " (267mm)	HDA-30ST-09
	12" (305mm)	13 ³ / ₁₆ " (335mm)	9" (229mm)	HDA-30ST-12
	18" (457mm)	11 ¹ / ₁₆ " (291mm)	6" (152mm)	HDA-30ST-18
	24" (610mm)	9 ³ / ₁₆ " (248mm)	3" (76mm)	HDA-30ST-24
36" (914mm)	6" (152mm)	16 ¹ / ₁₆ " (424mm)	15" (381mm)	HDA-36ST-06
	9" (229mm)	15 ³ / ₁₆ " (402mm)	13 ¹ / ₂ " (343mm)	HDA-36ST-09
	12" (305mm)	14 ¹ / ₁₆ " (379mm)	12" (305mm)	HDA-36ST-12
	18" (457mm)	13 ³ / ₁₆ " (335mm)	9" (229mm)	HDA-36ST-18
	24" (610mm)	11 ¹ / ₁₆ " (291mm)	6" (152mm)	HDA-36ST-24
	30" (762mm)	9 ³ / ₁₆ " (248mm)	3" (76mm)	HDA-36ST-30

Example: H4A-12LH-06

Note: Nominal 9" rung spacing maintained through centerline of all fittings.

Example: H4A-12ST-06

See Page 149
for Electrical
Grounding Chart

45°"Y" BRANCH LEFT HAND [LY] & RIGHT HAND [RY]

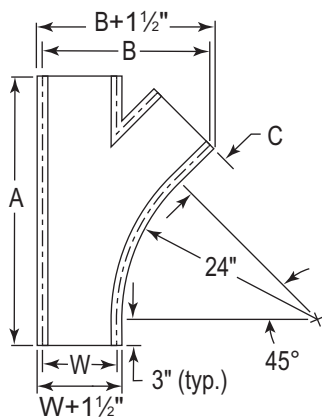
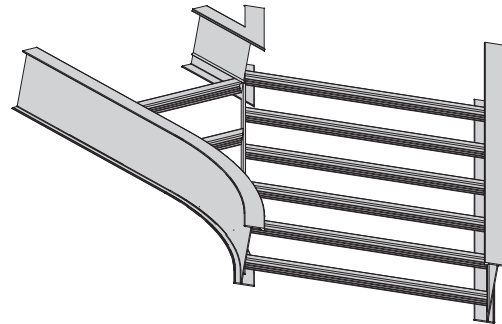
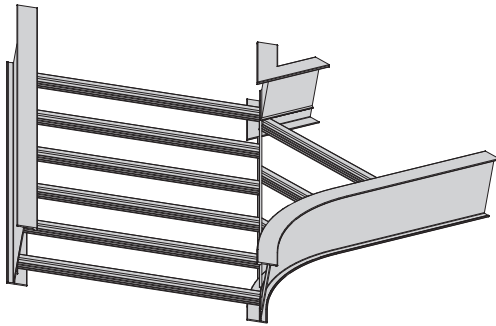

RIGHT HAND (RY)

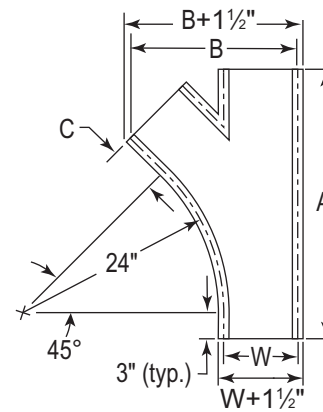

LEFT HAND (LY)

W	"A" Dimension	"B" Dimension	"C" Dimension	Part Number
6" (152mm)	28 ⁷ / ₁₆ " (722mm)	15 ¹ / ₁₆ " (386mm)	3 ¹ / ₁₆ " (78mm)	HDA-06(LY/R)
9" (229mm)	32 ¹¹ / ₁₆ " (830mm)	20 ⁵ / ₁₆ " (516mm)	6 ¹ / ₁₆ " (154mm)	HDA-09(LY/R)
12" (305mm)	36 ¹⁵ / ₁₆ " (938mm)	25 ⁹ / ₁₆ " (646mm)	9 ¹ / ₁₆ " (230mm)	HDA-12(LY/R)
18" (457mm)	45 ³ / ₈ " (1153mm)	35 ³ / ₁₆ " (910mm)	15 ¹ / ₁₆ " (383mm)	HDA-18(LY/R)
24" (610mm)	53 ³ / ₈ " (1368mm)	45 ⁵ / ₁₆ " (1167mm)	21 ¹ / ₁₆ " (535mm)	HDA-24(LY/R)
30" (762mm)	62 ³ / ₈ " (1584mm)	56 ³ / ₁₆ " (1427mm)	27 ¹ / ₁₆ " (687mm)	HDA-30(LY/R)
36" (914mm)	70 ¹³ / ₁₆ " (1799mm)	66 ⁷ / ₁₆ " (1688mm)	33 ¹ / ₁₆ " (840mm)	HDA-36(LY/R)

Example: H4A-12LY

Note: Nominal 9" rung spacing maintained through centerline of all fittings.

See Page 149
for Electrical
Grounding Chart

I-BEAM CABLE TRAY SYSTEM

90° VERTICAL ELBOW OUTSIDE [90] & INSIDE [91]

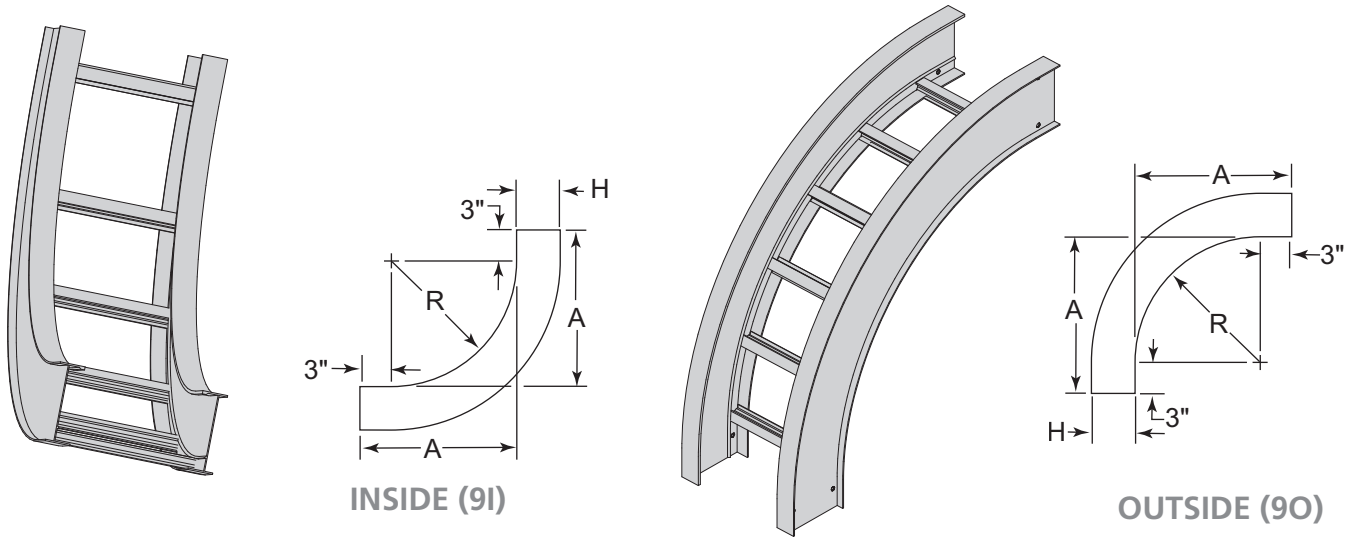

Radius (R)	Load Depth	Height (H)	A (Outside 90)	A (Inside 91)	Part Number
12" (305mm)	3" (76mm)	4 1/8" (105mm)	15" (381mm)	19 1/8" (486mm)	H3A-WW(90/91)-12
	4" (102mm)	5" (127mm)	15" (381mm)	20" (508mm)	H4A-WW(90/91)-12
	5" (127mm)	6 1/4" (159mm)	15" (381mm)	21 1/4" (540mm)	H5A-WW(90/91)-12
	6" (152mm)	7 1/4" (184mm)	15" (381mm)	22 1/4" (565mm)	H6A-WW(90/91)-12
	7" (179mm)	8" (203mm)	15" (381mm)	23" (584mm)	H7A-WW(90/91)-12
24" (610mm)	3" (76mm)	4 1/8" (105mm)	27" (686mm)	31 1/8" (791mm)	H3A-WW(90/91)-24
	4" (102mm)	5" (127mm)	27" (686mm)	32" (813mm)	H4A-WW(90/91)-24
	5" (127mm)	6 1/4" (159mm)	27" (686mm)	33 1/4" (845mm)	H5A-WW(90/91)-24
	6" (152mm)	7 1/4" (184mm)	27" (686mm)	34 1/4" (870mm)	H6A-WW(90/91)-24
	7" (1579mm)	8" (203mm)	27" (686mm)	35" (889mm)	H7A-WW(90/91)-24
36" (914mm)	3" (76mm)	4 1/8" (105mm)	39" (991mm)	43 1/8" (1095mm)	H3A-WW(90/91)-36
	4" (102mm)	5" (127mm)	39" (991mm)	44" (1118mm)	H4A-WW(90/91)-36
	5" (127mm)	6 1/4" (159mm)	39" (991mm)	45 1/4" (1149mm)	H5A-WW(90/91)-36
	6" (152mm)	7 1/4" (184mm)	39" (991mm)	46 1/4" (1175mm)	H6A-WW(90/91)-36
	7" (179mm)	8" (203mm)	39" (991mm)	47" (1194mm)	H7A-WW(90/91)-36

Example: H4A-1290-12

Note: Nominal 9" rung spacing maintained through centerline of all fittings.

See Page 149
for Electrical
Grounding Chart

60° VERTICAL ELBOW OUTSIDE [60] & INSIDE [61]

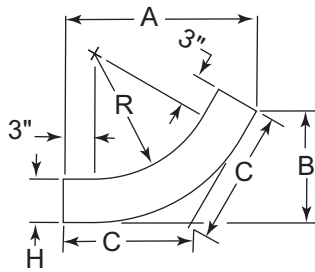
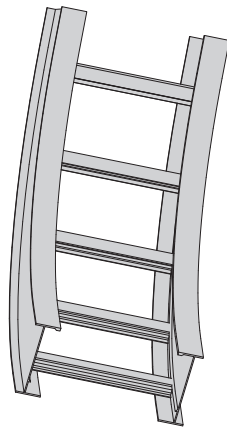

INSIDE (61)

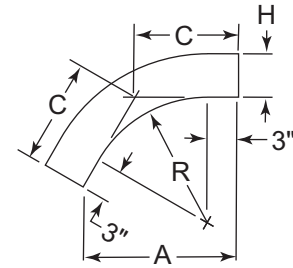
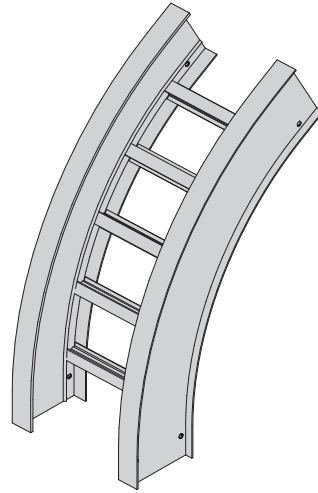

OUTSIDE (60)

Radius (R)	Load Depth	Height (H)	Outside (60)			Inside (61)			Part Number
			A	B	C	A	B	C	
12" (305mm)	3" (76mm)	4 1/8" (105mm)				18 1/16" (468mm)	10 1/16" (271mm)	12 5/16" (313mm)	H3A-WW(60/61)-12
	4" (102mm)	5" (127mm)				19 1/4" (489mm)	11 1/8" (283mm)	12 3/16" (325mm)	H4A-WW(60/61)-12
	5" (127mm)	6 1/4" (159mm)	14 7/8" (378mm)	8 5/8" (219mm)	9 5/16" (252mm)	20 9/16" (516mm)	11 3/4" (298mm)	13 3/16" (344mm)	H5A-WW(60/61)-12
	6" (152mm)	7 1/4" (184mm)				21 3/16" (538mm)	12 1/4" (311mm)	14 1/8" (359mm)	H6A-WW(60/61)-12
	7" (179mm)	8" (203mm)				21 13/16" (554mm)	12 5/8" (321mm)	14 3/16" (370mm)	H7A-WW(60/61)-12
24" (610mm)	3" (76mm)	4 1/8" (105mm)				28 7/8" (733mm)	16 1/16" (424mm)	19 1/4" (489mm)	H3A-WW(60/61)-24
	4" (102mm)	5" (127mm)				29 5/8" (752mm)	17 1/8" (435mm)	19 3/4" (502mm)	H4A-WW(60/61)-24
	5" (127mm)	6 1/4" (159mm)	25 5/16" (643mm)	14 5/8" (371mm)	16 7/8" (429mm)	30 11/16" (779mm)	17 3/4" (451mm)	20 7/16" (519mm)	H5A-WW(60/61)-24
	6" (152mm)	7 1/4" (184mm)				31 9/16" (802mm)	18 1/4" (464mm)	21 1/16" (535mm)	H6A-WW(60/61)-24
	7" (179mm)	8" (203mm)				32 3/16" (818mm)	18 5/8" (473mm)	21 1/2" (546mm)	H7A-WW(60/61)-24
36" (914mm)	3" (76mm)	4 1/8" (105mm)				39 1/4" (997mm)	22 1/16" (576mm)	26 3/16" (665mm)	H3A-WW(60/61)-36
	4" (102mm)	5" (127mm)				40" (1016mm)	23 3/8" (587mm)	26 1/16" (678mm)	H4A-WW(60/61)-36
	5" (127mm)	6 1/4" (159mm)	35 1/16" (906mm)	20 5/8" (524mm)	23 13/16" (605mm)	41 1/16" (1043mm)	23 3/4" (603mm)	27 7/8" (695mm)	H5A-WW(60/61)-36
	6" (152mm)	7 1/4" (184mm)				41 15/16" (1065mm)	24 1/4" (616mm)	28" (711mm)	H6A-WW(60/61)-36
	7" (179mm)	8" (203mm)				42 5/8" (1083mm)	24 5/8" (625mm)	28 3/8" (721mm)	H7A-WW(60/61)-36

See Page 149
for Electrical
Grounding Chart

I-BEAM CABLE TRAY SYSTEM

45° VERTICAL ELBOW OUTSIDE [40] & INSIDE [4I]

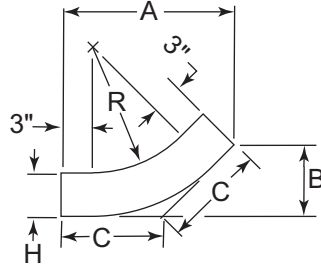
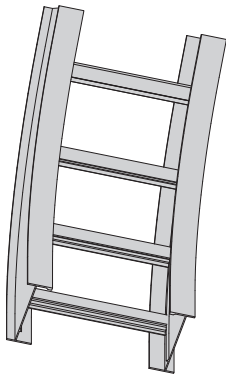

INSIDE (4I)

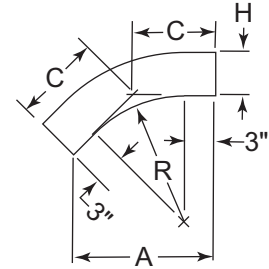
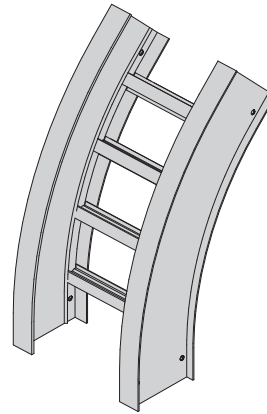

OUTSIDE (4O)

Radius (R)	Load Depth	Height (H)	Outside (4O)			Inside (4I)			Part Number
			A	B	C	A	B	C	
12" (305mm)	3" (76mm)	4 1/8" (105mm)	13 5/8" (346mm)	5 5/8" (143mm)	8" (203mm)	16 1/2" (419mm)	6 7/8" (175mm)	9 1/16" (246mm)	H3A-WW(40/4I)-12
	4" (102mm)	5" (127mm)				17 1/8" (435mm)	7 1/8" (181mm)	10 1/16" (256mm)	H4A-WW(40/4I)-12
	5" (127mm)	6 1/4" (159mm)				18" (457mm)	7 1/16" (189mm)	10 9/16" (268mm)	H5A-WW(40/4I)-12
	6" (152mm)	7 1/4" (184mm)				18 3/4" (476mm)	7 3/4" (197mm)	11" (279mm)	H6A-WW(40/4I)-12
	7" (179mm)	8" (203mm)				19 1/4" (489mm)	8" (203mm)	11 1/16" (287mm)	H7A-WW(40/4I)-12
24" (610mm)	3" (76mm)	4 1/8" (105mm)	22 1/16" (560mm)	9 1/8" (232mm)	12 15/16" (329mm)	25" (635mm)	10 3/8" (264mm)	14 5/8" (371mm)	H3A-WW(40/4I)-24
	4" (102mm)	5" (127mm)				25 5/8" (651mm)	10 5/8" (270mm)	15" (381mm)	H4A-WW(40/4I)-24
	5" (127mm)	6 1/4" (159mm)				26 1/2" (673mm)	11" (279mm)	15 1/2" (394mm)	H5A-WW(40/4I)-24
	6" (152mm)	7 1/4" (184mm)				27 3/16" (691mm)	11 1/4" (286mm)	15 15/16" (405mm)	H6A-WW(40/4I)-24
	7" (179mm)	8" (203mm)				27 3/4" (705mm)	11 1/2" (292mm)	16 1/4" (413mm)	H7A-WW(40/4I)-24
36" (914mm)	3" (76mm)	4 1/8" (105mm)	30 9/16" (776mm)	12 1 1/16" (322mm)	17 15/16" (456mm)	33 1/2" (851mm)	13 3/8" (352mm)	19 9/8" (498mm)	H3A-WW(40/4I)-36
	4" (102mm)	5" (127mm)				34 3/8" (867mm)	14 1/8" (359mm)	20" (508mm)	H4A-WW(40/4I)-36
	5" (127mm)	6 1/4" (159mm)				35" (889mm)	14 1/2" (368mm)	20 1/2" (521mm)	H5A-WW(40/4I)-36
	6" (152mm)	7 1/4" (184mm)				35 1 1/16" (906mm)	14 13/16" (376mm)	20 15/16" (532mm)	H6A-WW(40/4I)-36
	7" (179mm)	8" (203mm)				36 1/4" (921mm)	15" (381mm)	21 1/4" (540mm)	H7A-WW(40/4I)-36

Example: H4A-1240-12

Note: Nominal 9" rung spacing maintained through centerline of all fittings.

See Page 149
for Electrical
Grounding Chart

30° VERTICAL ELBOW OUTSIDE [30] & INSIDE [31]

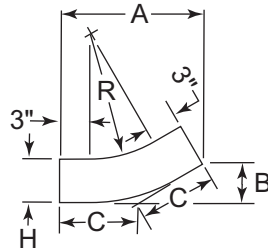
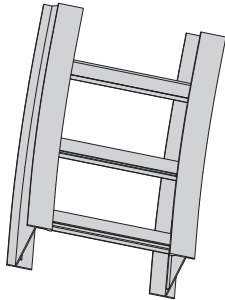

INSIDE (31)

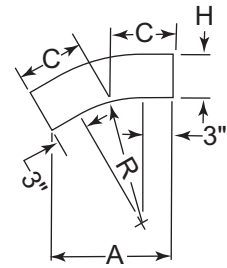
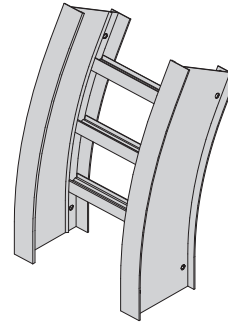

OUTSIDE (30)

Radius (R)	Load Depth	Height (H)	Outside (30)			Inside (31)			Part Number
			A	B	C	A	B	C	
12" (305mm)	3" (76mm)	4 1/8" (105mm)	11 5/8" (295mm)	3 7/8" (79mm)	6 3/16" (157mm)	13 1/16" (348mm)	3 1/16" (94mm)	7 5/16" (186mm)	H3A-WW(30/31)-12
	4" (102mm)	5" (127mm)				14 5/8" (359mm)	3 3/4" (95mm)	7 7/16" (192mm)	H4A-WW(30/31)-12
	5" (127mm)	6 1/4" (159mm)				14 3/4" (375mm)	3 5/16" (100mm)	7 7/8" (200mm)	H5A-WW(30/31)-12
	6" (152mm)	7 1/4" (184mm)				15 1/4" (387mm)	4 1/16" (103mm)	8 5/16" (208mm)	H6A-WW(30/31)-12
	7" (179mm)	8" (203mm)				15 5/8" (397mm)	4 3/16" (106mm)	8 3/8" (213mm)	H7A-WW(30/31)-12
24" (610mm)	3" (76mm)	4 1/8" (105mm)	17 7/8" (448mm)	4 1 1/16" (119mm)	9 7/16" (240mm)	19 11/16" (500mm)	5 1/4" (133mm)	10 9/16" (268mm)	H3A-WW(30/31)-24
	4" (102mm)	5" (127mm)				20 5/8" (511mm)	5 5/8" (137mm)	10 3/4" (273mm)	H4A-WW(30/31)-24
	5" (127mm)	6 1/4" (159mm)				20 3/4" (527mm)	5 9/16" (141mm)	11 1/8" (283mm)	H5A-WW(30/31)-24
	6" (152mm)	7 1/4" (184mm)				21 1/4" (540mm)	5 1 1/16" (144mm)	11 3/8" (289mm)	H6A-WW(30/31)-24
	7" (179mm)	8" (203mm)				21 5/8" (549mm)	5 3/16" (148mm)	11 1/8" (294mm)	H7A-WW(30/31)-24
36" (914mm)	3" (76mm)	4 1/8" (105mm)	23 3/8" (600mm)	6 5/16" (160mm)	12 5/8" (321mm)	25 1/16" (652mm)	6 7/8" (175mm)	13 3/4" (349mm)	H3A-WW(30/31)-36
	4" (102mm)	5" (127mm)				26 1/8" (664mm)	7" (178mm)	14" (356mm)	H4A-WW(30/31)-36
	5" (127mm)	6 1/4" (159mm)				26 3/4" (679mm)	7 3/16" (183mm)	14 5/16" (364mm)	H5A-WW(30/31)-36
	6" (152mm)	7 1/4" (184mm)				27 1/4" (692mm)	7 7/16" (186mm)	14 9/16" (376mm)	H6A-WW(30/31)-36
	7" (179mm)	8" (203mm)				27 5/8" (702mm)	7 3/8" (187mm)	14 13/16" (370mm)	H7A-WW(30/31)-36

Example: H4A-1231-12

Note: Nominal 9" rung spacing maintained through centerline of all fittings.

See Page 149
for Electrical
Grounding Chart

I-BEAM CABLE TRAY SYSTEM

90° VERTICAL CABLE SUPPORT ELBOW [SR]

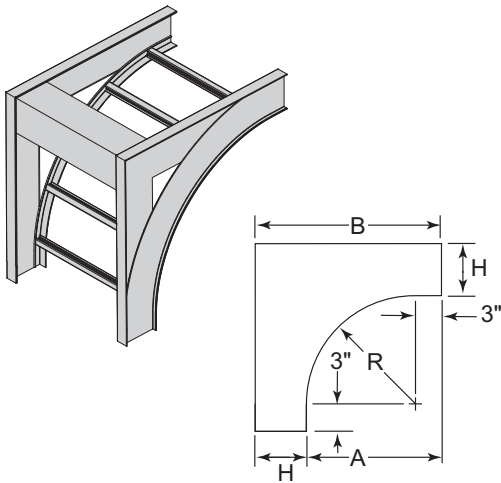

Radius (R)	Load Depth	H	A	B	Part Number
12" (305mm)	3" (76mm)	4 1/8" (105mm)	15" (381mm)	19 1/8" (486mm)	H3A-WWSR-12
	4" (102mm)	5" (127mm)		20" (508mm)	H4A-WWSR-12
	5" (127mm)	6 1/4" (159mm)		21 1/4" (540mm)	H5A-WWSR-12
	6" (152mm)	7 1/4" (184mm)		22 1/4" (565mm)	H6A-WWSR-12
	7" (179mm)	8" (203mm)		23" (584mm)	H7A-WWSR-12
24" (610mm)	3" (76mm)	4 1/8" (105mm)	27" (686mm)	21 1/8" (537mm)	H3A-WWSR-24
	4" (102mm)	5" (127mm)		32" (813mm)	H4A-WWSR-24
	5" (127mm)	6 1/4" (159mm)		33 3/4" (845mm)	H5A-WWSR-24
	6" (152mm)	7 1/4" (184mm)		34 3/4" (870mm)	H6A-WWSR-24
	7" (179mm)	8" (203mm)		35" (889mm)	H7A-WWSR-24
36" (914mm)	3" (76mm)	4 1/8" (105mm)	39" (991mm)	43 1/8" (1095mm)	H3A-WWSR-36
	4" (102mm)	5" (127mm)		44" (1118mm)	H4A-WWSR-36
	5" (127mm)	6 1/4" (159mm)		45 1/4" (1149mm)	H5A-WWSR-36
	6" (152mm)	7 1/4" (184mm)		46 1/4" (1175mm)	H6A-WWSR-36
	7" (179mm)	8" (203mm)		47" (1194mm)	H7A-WWSR-36

Example: H4A-12SR-12

VERTICAL TEE DOWN [VT] & UP [OT]

VERTICAL TEE - DOWN (VT)

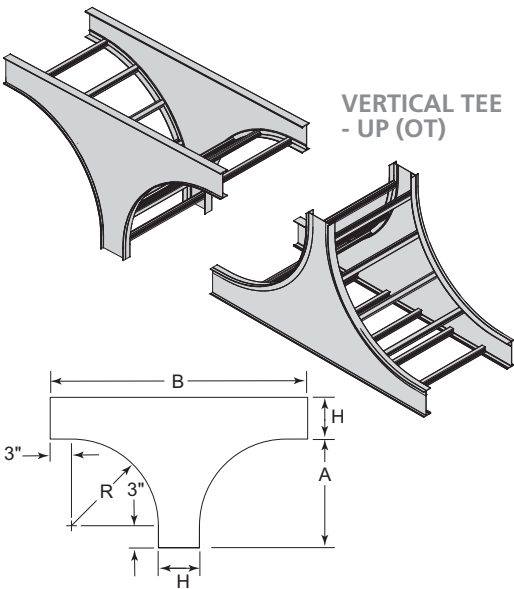

Radius (R)	Load Depth	H	A	B	Part Number
12" (305mm)	3" (76mm)	4 1/8" (105mm)	15" (381mm)	34 1/8" (867mm)	H3A-WW(VT/OT)-12
	4" (102mm)	5" (127mm)		35" (889mm)	H4A-WW(VT/OT)-12
	5" (127mm)	6 1/4" (159mm)		36 1/4" (921mm)	H5A-WW(VT/OT)-12
	6" (152mm)	7 1/4" (184mm)		37 1/4" (946mm)	H6A-WW(VT/OT)-12
	7" (179mm)	8" (203mm)		38" (965mm)	H7A-WW(VT/OT)-12
24" (610mm)	3" (76mm)	4 1/8" (105mm)	27" (686mm)	58 1/8" (1476mm)	H3A-WW(VT/OT)-24
	4" (102mm)	5" (127mm)		59" (1499mm)	H4A-WW(VT/OT)-24
	5" (127mm)	6 1/4" (159mm)		60 1/4" (1530mm)	H5A-WW(VT/OT)-24
	6" (152mm)	7 1/4" (184mm)		61 1/4" (1556mm)	H6A-WW(VT/OT)-24
	7" (179mm)	8" (203mm)		62" (1575mm)	H7A-WW(VT/OT)-24
36" (914mm)	3" (76mm)	4 1/8" (105mm)	39" (991mm)	82 1/8" (2086mm)	H3A-WW(VT/OT)-36
	4" (102mm)	5" (127mm)		83" (2108mm)	H4A-WW(VT/OT)-36
	5" (127mm)	6 1/4" (159mm)		84 1/4" (2140mm)	H5A-WW(VT/OT)-36
	6" (152mm)	7 1/4" (184mm)		85 1/4" (2165mm)	H6A-WW(VT/OT)-36
	7" (179mm)	8" (203mm)		86" (2184mm)	H7A-WW(VT/OT)-36

Note: Nominal 9" rung spacing maintained through centerline of all fittings.

Example: H4A-12VT-12

See Page 149
for Electrical
Grounding Chart

TRAY CONNECTORS

CATALOG NUMBER (ALUMINUM)

Part	Load Depth	Basic No.
H3A	3"	-02RC
H4A	4"	-02CE
H5A	5"	-02CV
H6A	6"	-02CH
H7A	7"	-02CA

Example: H3A -02RC for I-Beam flange, 3" load depth, aluminum, universal curvilinear connector.

Note: Hole patterns match corresponding tray. Three-hole pattern illustrated.

UNIVERSAL CONNECTOR [RC]

Note: Sold in pairs

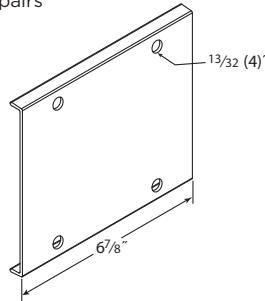

11 Gage Steel, 0.125" Aluminum
3/8"-16 spline bolts & flange nuts furnished.

EXPANSION CONNECTOR [CE]

Note: Sold in pairs

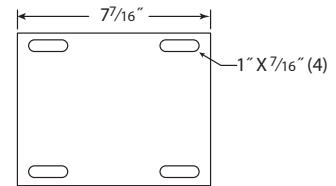

11 Gage Steel, 0.125" Aluminum
3/8"-16 cap screws & Nylok nuts furnished and 3/8"-16 spline bolts & flange nuts furnished.

Note: Bonding Jumpers are required and are sold separately.

MID-SPAN SPLICE PLATE [RC]

3/8" - Aluminum

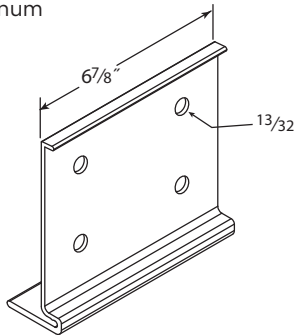

CATALOG NUMBER

Part	Use With System
H5A-02RC-MID	7H5A, 9H5A
H6A-02RC-MID	7H6A, 9H6A

HORIZONTAL ADJUSTABLE CONNECTOR [CH]

Note: Sold in pairs - inner & outer

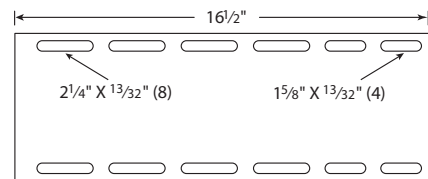
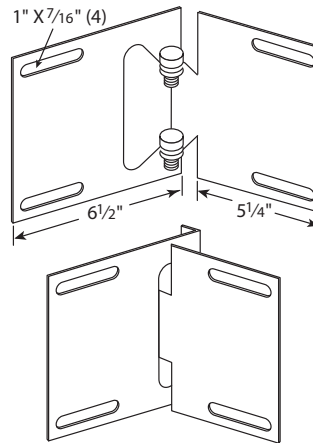

0.125" Aluminum
Horizontal Adjustable Splice Plate to be used with HCH hinge
3/8"-16 spline bolts and flange nuts furnished.

MID-SPAN SPLICE PLATE [RC]

Catalog Number: H7A-02RCOMID

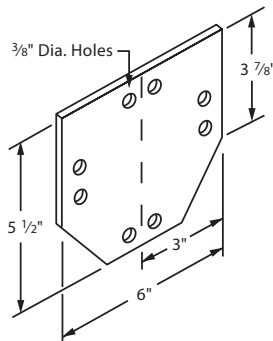

3/8" - Aluminum
For use with 11H7A Systems.

See Page 149 for Electrical Grounding Chart

Note: not sold in pairs

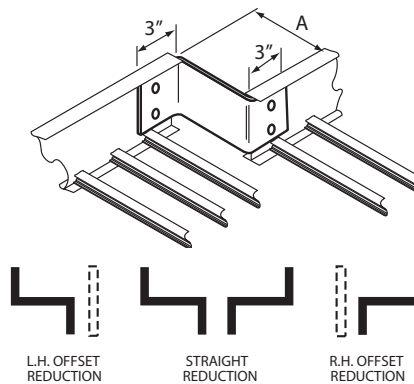

0.125" Aluminum

For offset reductions – use 1 of above with standard connector plate.

For straight reductions– use 2 (of 1/2 reduction dim.).
3/8"-16 spline bolts and flange nuts furnished.

REDUCING CONNECTOR [CO]

CATALOG NUMBER (ALUMINUM)

Part	Load Depth	Basic Number	"A" Dimension
H3A	3"	-30CO	30" (762mm)
H4A	4"	-27CO	27" (686mm)
H5A	5"	-24CO	24" (610mm)
H6A	6"	-21CO	21" (533mm)
H7A	7"	-18CO	18" (457mm)
		-15CO	15" (381mm)
		-13CO	13 1/2" (343mm)
		-12CO	12" (305mm)
		-10CO	10 1/2" (267mm)
		-09CO	9" (229mm)
		-07CO	7 1/2" (191mm)
		-06CO	6" (152mm)
		-04CO	4 1/2" (114mm)
		-03CO	3" (76mm)
		-01CO	1 1/2" (38mm)

Example: H3A-03CO for I-Beam flange, 3" load depth, aluminum, 3" Reducer Connector. Typical Use: 9" to 6", or use 2 for 12" to 6", etc.

I-BEAM CABLE TRAY SYSTEM

CONNECTOR PLATES

VERTICAL ADJUSTABLE CONNECTOR [CV]

11 Gage Steel, 0.125" Aluminum
 $\frac{3}{8}$ "-16 spline bolts & flange nuts furnished.

Note: Sold in pairs

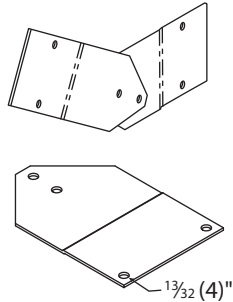

HEAVY DUTY HOLD DOWN BRACKET [7-HDHDB]

2 - $\frac{3}{8}$ " Holes & 2 - $\frac{1}{2}$ " Holes.

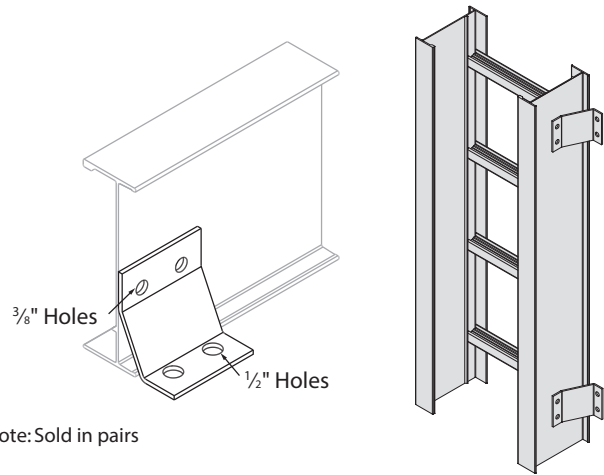

Note: Sold in pairs

VERTICAL ADJ. BRANCH PIVOT CONNECTOR [BPC]

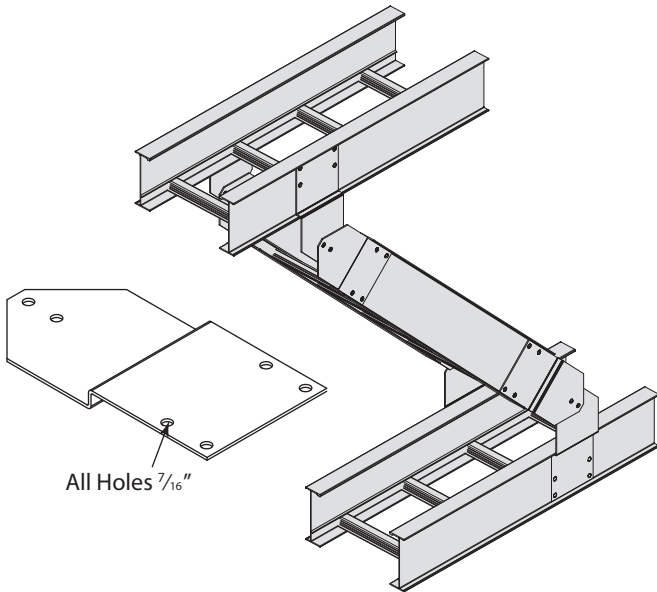

All Holes $\frac{7}{16}$ "

CROSS CONNECTION BRACKET [CCB]

4 - $\frac{3}{8}$ " Holes

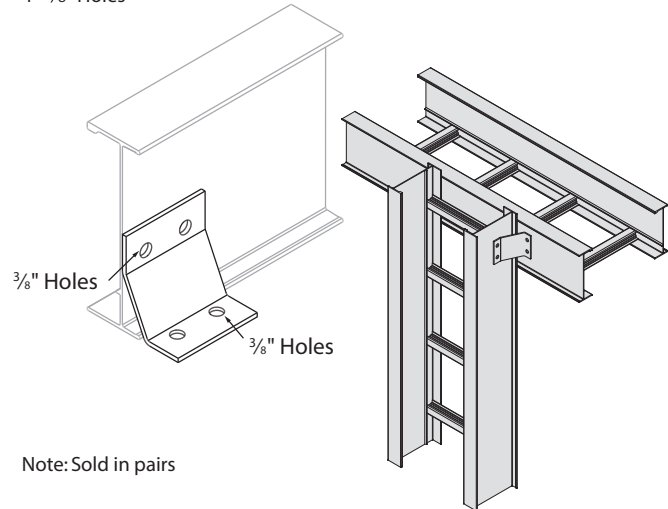

Note: Sold in pairs

VERTICAL HANGER SPLICE PLATE [VH]

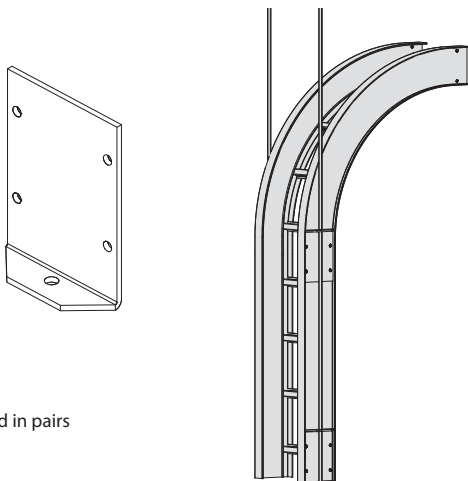

Note: Sold in pairs

Catalog No.	For Use With Cope System Number
H-9043-412	5H3A
H-9043-500	5H4A
H-9043-619	7H5A
H-9043-724	7H6A
H-9043-624	9H5A
H-9043-724	9H6A
H-9043-800	11H7A

I-Beam Supports can be bolted anywhere along the straight runs. They can be bolted directly onto the coupler plates at splices of straight runs and riser fittings, or they can be bolted at any place in the run by field-drilling side rails. I-Beam supports are used with either $\frac{3}{8}$ " or $\frac{1}{2}$ " hanger rods. Finish is aluminum.

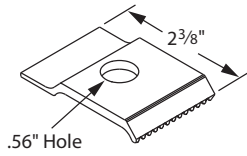

9131A

Catalog No.	Material
9131A	Aluminum
H6A-02RC-MID	Stainless Steel Type 316

Hardware purchased separately to suit support system.



PS NS

Catalog No. 9131A-HDW (Complete Hardware Kit)

Hardware list:

- (2) 9131A Combination hold-down clamp & expansion guides
- (2) PS 6024 - 1/2" - 13 x 1 1/4" Cap Screw
- (2) PS 209 - 1/2" Flat Washer
- (2) PS NS - Clamping Nut (Strut Nut)

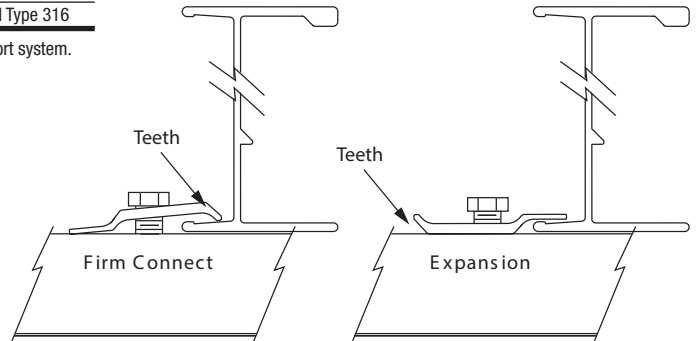

COMBINATION HOLD-DOWN / EXPANSION GUIDE [9053]

Universal Guide: for either side of ladder. Use when tray is mounted on I-beams or channels. No drilling required.

Note: Use set screws for firm hold down

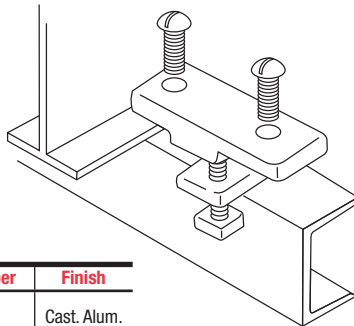

Type	Catalog Number	Finish
Combination Guide	8-9053	Cast. Alum.

Note: Electroplated set screws included

ISOLATION PAD [9131-IP]

The Isolation pad provides protection from galvanic corrosion when Aluminum tray is mounted on steel supports.

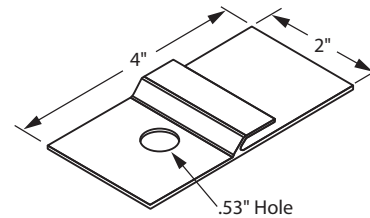

Note: For use with the 9131A-HDW shown above.

Hardware purchased separately

BOX SPLICE PLATE [CA]

Note: Sold in pairs

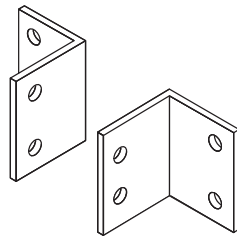

Use to attach the end of a cable tray to a distribution box or control panel.

CATALOG NUMBER

Part	Load Depth	Finish	Basic No.
H3A	3"	A - Alum.	-02CA
H4A	4"		
H5A	5"		
H6A	6"		
H7A	7"		

Example: H4A -02CA for 4" load depth, aluminum Box Splice Plate.

HOLD-DOWN [9132]

Note: For seismic applications or other bolted connections is preferred.

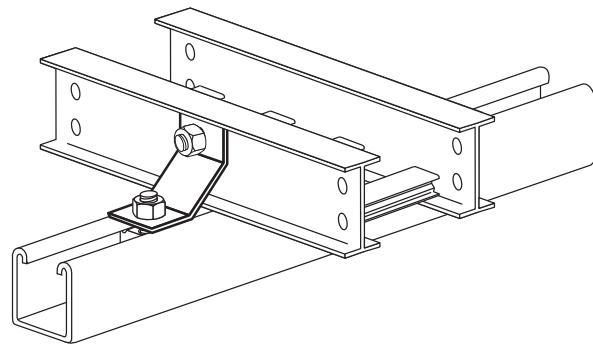

Catalog No.	Material
9132	Mill Galvanized
9133	Stainless Steel

Hardware purchased separately to suit support system.

I-BEAM CABLE TRAY SYSTEM

HARDWARE

MATERIAL/FINISH

Electrogalvanized finish standard. Other finishes available; consult factory.

*Use following suffix when applicable - use only where indicated.

NO SUFFIX Electrogalvanized carbon steel only

-SS 302/304 Stainless Steel

-S1 316 Stainless Steel (check factory for availability)

Example: PS 6024 3/8" x 1 1/2" SS, 3/8" x 1 1/2" hex head bolt, 304 stainless steel

CONNECTOR HARDWARE

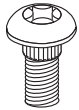

Spline Bolt



Hex-Flanged Nut with Serrated Washer Face

Catalog Number	Item	Size	Material
5003-1	Spline Bolt	3/8" - 16 x 1"	Case-Hardened Steel electrogalvanized
5003-2-S1	Spline Bolt	1/2" - 13 x 1"	Stainless Steel
5009-1	Hex Nut	3/8" - 16	Case-Hardened Steel electrogalvanized
5009-2-S1	Hex Nut	1/2" - 13	Stainless Steel

COVER SCREW [EM]

Part No. EM-CC (electrogalv. steel)
Part No. EM-CC-SS (stainless steel)

No. 10 x 5/8" long, self drilling-self tapping hex head plated steel screw.

Suggested spacing:
Indoor: 8 per 12';
Outdoor: 10 per 12'

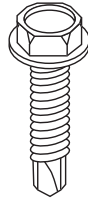

CONTINUOUS THREADED ROD [PS 146]

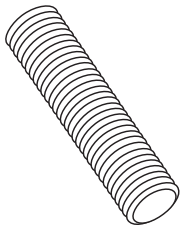

Cat. No.	Size (Diameter x Length)
PS 146*	1/4" x 10'
PS 146*	3/8" x 10'
PS 146*	1/2" x 10'
PS 146*	5/8" x 10'
PS 146*	3/4" x 10'

(Hot Dip Galvanized not available)

ROD COUPLER [PS 135]

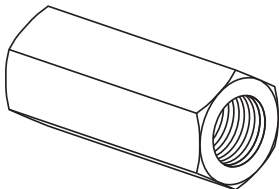

Cat. No.	Size
PS 135*	1/4"
PS 135*	3/8"
PS 135*	1/2"
PS 135*	5/8"
PS 135*	3/4"

HEX NUTS [PS 83]

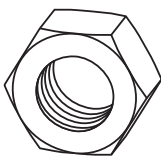

Cat. No.	Size
PS 83*	1/4"
PS 83*	3/8"
PS 83*	1/2"
PS 83*	5/8"
PS 83*	3/4"

SQUARE NUTS [PS 6108]

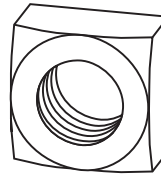

Cat. No.	Size
PS 6108*	1/4"
PS 6108*	3/8"
PS 6108*	1/2"
PS 6108*	5/8"
PS 6108*	3/4"

FLAT WASHERS [PS 209]

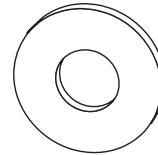

Cat. No.	Size
PS 209*	1/4"
PS 209*	3/8"
PS 209*	1/2"
PS 209*	5/8"
PS 209*	3/4"

SPLIT-LOCK WASHERS [PS 211]

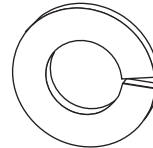

Cat. No.	Size
PS 211*	1/4"
PS 211*	3/8"
PS 211*	1/2"
PS 211*	5/8"
PS 211*	3/4"

FENDER WASHERS [PS 230]

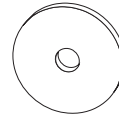

Cat. No.	Size (I.D. x O.D.)
PS 230*	1/4" x 1 1/4" O.D.
PS 230*	3/8" x 1 1/2" O.D.
PS 230*	1/2" x 2" O.D.

HEX HEAD CAP SCREW / ROUND HEAD, SLOTTED CAP SCREW [PS 6024]

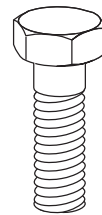

Catalog No. PS 6024

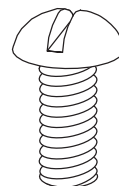

Catalog No. PS 6072

Hex Head Cap Screw Cat. No.	Round Head Cap Screw Cat. No.	Size (Dia. x Len.)
PS 6024*	PS 6072*	1/4" x 1"
PS 6024*	PS 6072*	1/4" x 1 1/2"
PS 6024*	PS 6072*	3/8" x 1"
PS 6024*	PS 6072*	3/8" x 1 1/2"
PS 6024*	PS 6072*	3/8" x 3"
PS 6024*	PS 6072*	1/2" x 1"
PS 6024*	PS 6072*	1/2" x 1 1/2"
PS 6024*	PS 6072*	1/2" x 2"
PS 6024*	PS 6072*	1/2" x 2 1/2"
PS 6024*	PS 6072*	1/2" x 3"
PS 6024*	PS 6072*	1/2" x 3 1/2"
PS 6024*	PS 6072*	5/8" x 1 1/2"
PS 6024*	PS 6072*	5/8" x 2"
PS 6024*	PS 6072*	5/8" x 3"
PS 6024*	PS 6072*	5/8" x 4"
PS 6024*	PS 6072*	3/4" x 2"
PS 6024*	PS 6072*	3/4" x 3"
PS 6024*	PS 6072*	3/4" x 4"

COVERS for straight sections shown. Standard fitting covers are flat solid type (NF). Aluminum covers are fabricated from 0.040" aluminum AA-3150-H14.

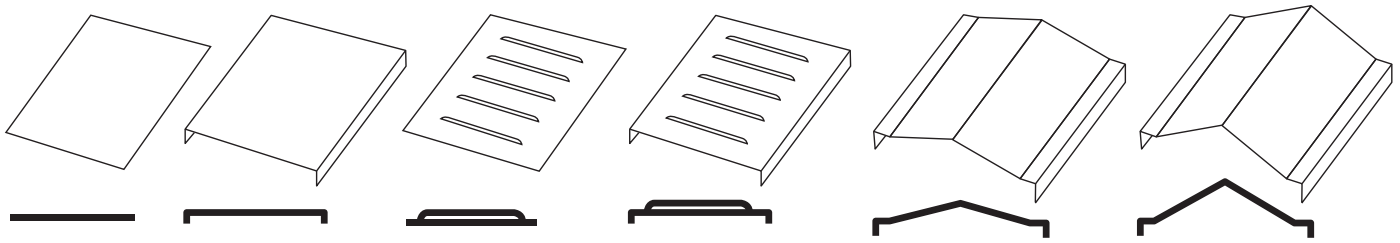

NF – Flat Solid

FS – Flat Solid
w/ $\frac{3}{8}$ " Flange

NL – Flat Louvered

PF – Peaked Flanged
Solid w/ $\frac{3}{8}$ " Flange
(suffix height)

PP – Peaked 2 to 3 Pitch
Flanged Solid
w/ $\frac{3}{8}$ " Flange

Note: Use EM-CC Cover Screws (see pg. 57) to attach PH, PV, HS & HV covers.

COVER CATALOG NUMBER – STRAIGHT SECTIONS (ALUMINUM)

Type	Basic No. (Width)	Length	Height*
NFHA	-06SL = 6" (152mm)	-12'	-2*
FSHA	-09SL = 9" (229mm)	-10'	
NLHA	-12SL = 12" (305mm)	-06'	
PFHA	-18SL = 18" (457mm)		
PPHA	-24SL = 24" (610mm)		
	-30SL = 30" (762mm)		
	-36SL = 36" (914mm)		

*PF only, 2" height standard. Consult factory for other heights.

Example: NLHA-09SL-12 is a flat louvered aluminum cover for a 9" wide I-Beam 12' long

COVER CATALOG NUMBER – FITTINGS (ALUMINUM)

Type	Load Depth	Width/Basic No.	Radius
NFHA	3"	-06 XX **	12"
FSHA	4"	-09 XX **	24"
	5"	-12 XX **	36"
	6"	-18 XX **	
		-24 XX **	
		-30 XX **	
		-36 XX **	

* Load depth for outside riser or vertical tee only.

** XX from fitting selection page 68

Example: NFH6-369F-24 is a non-flanged solid cover for a 36" wide horizontal 90° elbow with a 24" radius

JOINT PLATE

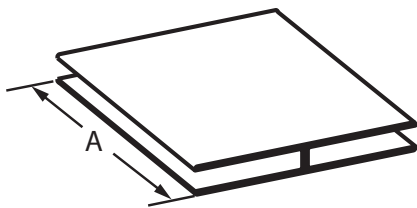

Joint plate is black PVC and is offered in 10' lengths to be field cut to desired length, or in pre-cut lengths for specified covers.

JO-120 is joint plant in 10' lengths.

Joint plate for specified covers is specified as follows.

Tray Width "A"	
JP-06 = 6"	(152mm)
JP-09 = 9"	(229mm)
JP-12 = 12"	(305mm)
JP-18 = 18"	(457mm)
JP-24 = 24"	(610mm)
JP-30 = 30"	(762mm)
JP-36 = 36"	(914mm)

Example: JP-06 is a joint plate for 6" wide tray.

I-BEAM CABLE TRAY SYSTEM

COVER ACCESSORIES

DOUBLE CLAMP CONNECTOR [DC]

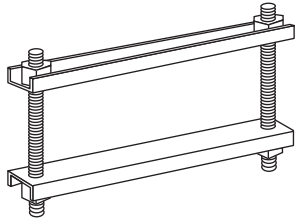

For all covers except hat & peak type. Furnished with:
 (2) 1/4"-20 all-thread rods
 (4) hex nuts, flat washers
 and lock washers.

CATALOG NUMBER (ALUMINUM CLAMP)

Part	Load Depth	Width	Type
H3A	3"	-06	DC
H4A	4"	-09	
H5A	5"	-12	
H6A	6"	-18	
H7A		-24 -30	
		-36	

Suggested spacing:
 Indoor: 2 per 12'
 Outdoor: 3 per 12'
 High Wind: 5 per 12'

Example: H4A-12DC for 4" load depth, I-Beam flange, aluminum, Double Clamp Connector

PEAK COVER CONNECTOR [PC]

Note: For PF Covers

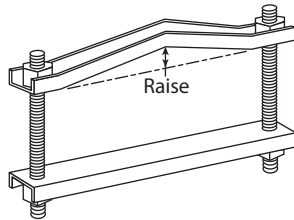

CATALOG NUMBER (ALUMINUM CLAMP)

Part	Load Depth	Width	Type	Raise (in)*
H3A	3"	-06, -09	PC	-2
H4A	4"	-12, -18		
H5A	5"	-24, -30		
H6A	6"	-36		
H7A	7"			

*2" standard raise. Consult factory for other peak heights.

Example: H4A-12PC-2 for 4" load depth, I-Beam flange, aluminum, 12" wide, Peak Cover Connector with 2" peak.

PEAK PITCH COVER CONNECTOR [PP]

NOTE: For PP Covers

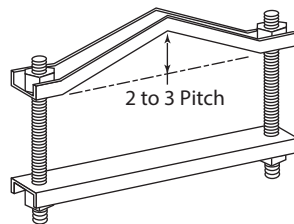

CATALOG NUMBER (ALUMINUM)

Part	Load Depth	Width	Type
H3A	3"	-06, -09	PP
H4A	4"	-12, -18	
H5A	5"	-24, -30	
H6A	6"	-36	
H7A	7"		

Note: 2 to 3 standard pitch.

Example: H4A-12PP for 4" load depth, I-Beam flange, aluminum, 12" wide, Pitched Peak Cover

ELEVATED COVER CONNECTORS [EM-CC]

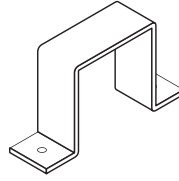

Includes:
 (3) #10 x 5/8" Self drilling screws.
 Suggested spacing:
 Indoor: 3/Side (6 tot.) per 12';

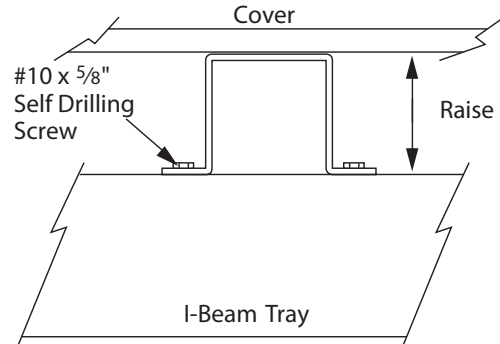

Finish	Type	Height*
8=Alum.	EM-CC	- Raise* (in.)

*1", 2" or 3" standard.

Example: 8-EM-CC-2 for aluminum, Elevated Cover Connector with a 2" raise

ELECTRO-GALV. STEEL COVER CLIP [PS 135X]

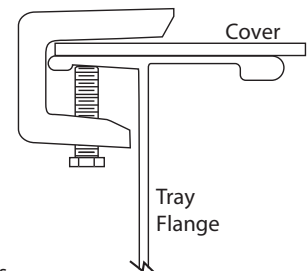
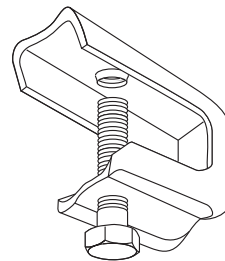

Use with any width tray. Not sold in pairs.
 Indoor use only. Suggest spacing 6' max.

BOX CONNECTOR [CB]

.080" Aluminum.

Note: 1/4"-20 carriage bolts, flat washers, hex nuts furnished

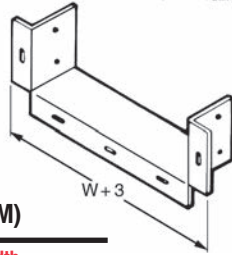

CATALOG NUMBER (ALUMINUM)

Part	Load Depth	Width
H3A	3"	-06CB = 6" (152mm)
H4A	4"	-09CB = 9" (229mm)
H5A	5"	-12CB = 12" (305mm)
H6A	6"	-18CB = 18" (457mm)
H7A	7"	-24CB = 24" (610mm)
		-30CB = 30" (762mm)
		-36CB = 36" (914mm)

Example: H4A-12CB for I-Beam flange, 4" load depth, aluminum, 12" wide, Box Connector.

DROP OUT [DO]

.080" Aluminum.

Note: (2) #10 x 5/8" self tapping screws furnished.

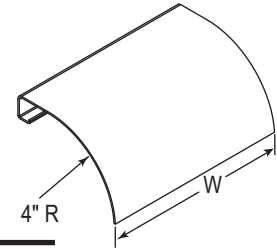

Basic Finish	Width
A - Alum.	-06DO = 6" (152mm)
	-09DO = 9" (229mm)
	-12DO = 12" (305mm)
	-18DO = 18" (457mm)
	-24DO = 24" (610mm)
	-30DO = 30" (762mm)
	-36DO = 36" (914mm)

Example: A-12DO for aluminum, 12" wide, Drop Out

BLIND END [BE]

.040" Aluminum

Note: 3/8"-16 spline bolts and flange nuts furnished.

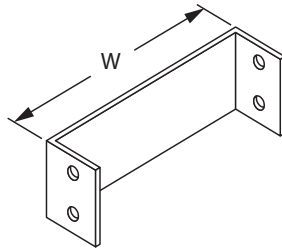

Part	Load Depth	Width
H3A	3"	-06BE = 6" (152mm)
H4A	4"	-09BE = 9" (229mm)
H5A	5"	-12BE = 12" (305mm)
H6A	6"	-18BE = 18" (457mm)
H7A	7"	-24BE = 24" (610mm)
		-30BE = 30" (762mm)
		-36BE = 36" (914mm)

Example: H4A-12BE for I-Beam flange, 4" load depth, aluminum, 12" wide, Box Connector.

BONDING JUMPER [CBJ]

Note: No hardware supplied

For hardware kit add -HDW:

Ex: CBJ-C-HDW includes
2ea CBJ-C
4ea 5003-1
4ea 5009-1

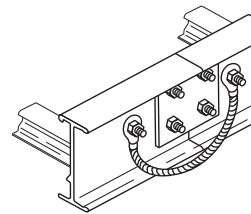

Catalog No.	Dimensional Data	Amperes as Equipment Ground
CBJ-C	AWG 1/0 copper wire 15 1/2" long overall	800 amperes
CBJ-4C	AWG 4/0 copper wire 15 1/2" long overall	1,600 amperes
CBJ-250C	250 MCM copper wire 15 1/2" long overall	2,000 amperes

CABLE TRAY GROUND CLAMP [9156]

Extruded Alum. with ElectroGalvanized Hex Head Screws

Capacity: #6 AWG to 250 kcmil

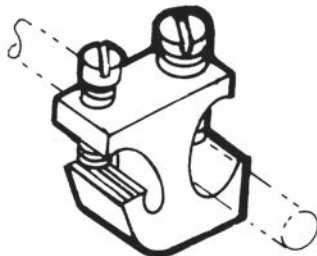
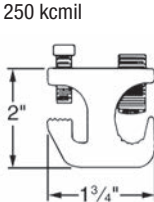

UL Listed E-24264

Certified File No. LR 9795

GROUND CABLE RETAINER CLAMP

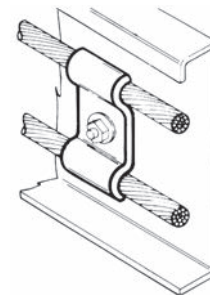

Catalog No.	Capacity	Metal & Finish	Dimensions
9056-EP	1/0 2/0 3/0	Electro-Galv. Steel	1" w x 2" long
9057-EP	4/0 250 MCM	Electro-Galv. Steel	1" w x 2 3/8" long
9056-SS	1/0 2/0 3/0	Stainless Steel	1" w x 2" long
9057-SS	4/0 250 MCM	Stainless Steel	1" w x 2 3/8" long

I-BEAM CABLE TRAY SYSTEM

ACCESSORIES

MUSTANG UNIVERSAL ONE-PIECE PIPE, CONDUIT (GRC, EMT & IMC) AND TUBING CLAMPS [PS MU]

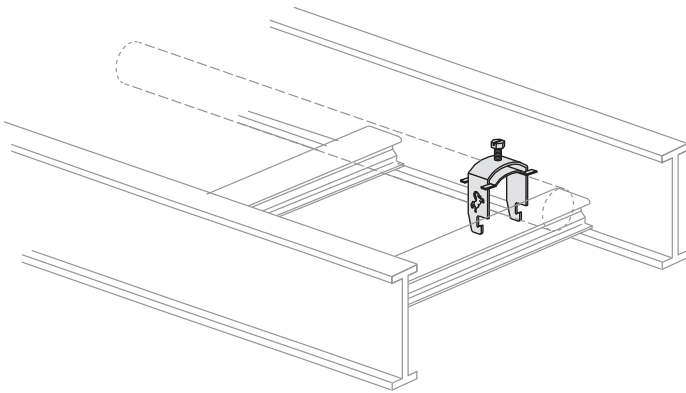

Note: Available in 14 ga. Electro-galvanized steel

Part No.	Nominal Trade Size	OD		Height Above Channel"H"	
		Min	Max	Min	Max.
PS MU-¼	¼"	0.250"	0.540"	1¾"	2"
PS MU-⅜	⅜"	0.500"	0.675"	1⅞"	2⅛"
PS MU-½	½"	0.625"	0.840"	2"	2¼"
PS MU-¾	¾"	0.875"	1.050"	2¼"	2½"
PS MU-1	1"	1.125"	1.315"	2½"	2¾"
PS MU-1¼	1¼"	1.375"	1.660"	2¾"	3⅛"
PS MU-1½	1½"	1.625"	1.900"	3"	3⅜"
PS MU-2	2"	2.000"	2.375"	3½"	3⅞"
PS MU-2½	2½"	2.500"	2.875"	4¼"	4⅝"
PS MU-3	3"	3.000"	3.500"	4⅞"	5⅝"
PS MU-3½	3½"	3.625"	4.000"	5⅞"	5⅞"
PS MU-4	4"	4.125"	4.500"	5⅞"	6⅞"

CONDUIT CLAMP BRACKET [CCB]



Catalog No.	Size-Rigid	Size-EMT
CCB-050	⅜" to ½"	½"
CCB-075	¾"	¾"
CCB-100	1"	1"
CCB-125	-	1 ¼"
CCB-150	1 ¼"	1 ½"
CCB-200	2"	2"

CONDUIT-TO-CABLE TRAY CLAMP SWIVEL TYPE (TB)

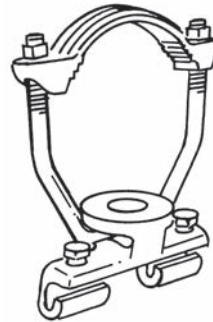

Malleable iron hub and steel "U" bolt. For connecting and grounding rigid conduit to tray at any angle within 90° arc. U.L. listed as a grounding means.

Catalog No.	Size	Std. Pkg.
TB6209	½"-¾"	10
TB6211	1"-1 ¼"	10
TB6214	1 ½"-2"	5
TB6216	2 ½"-3"	5
TB6218	3 ½"-4"	2

WALL PENETRATING SLEEVE ASSEMBLY

Part No. SS89042(W)*

W = Tray Width
 *=Fitting 3-Digit Prefix

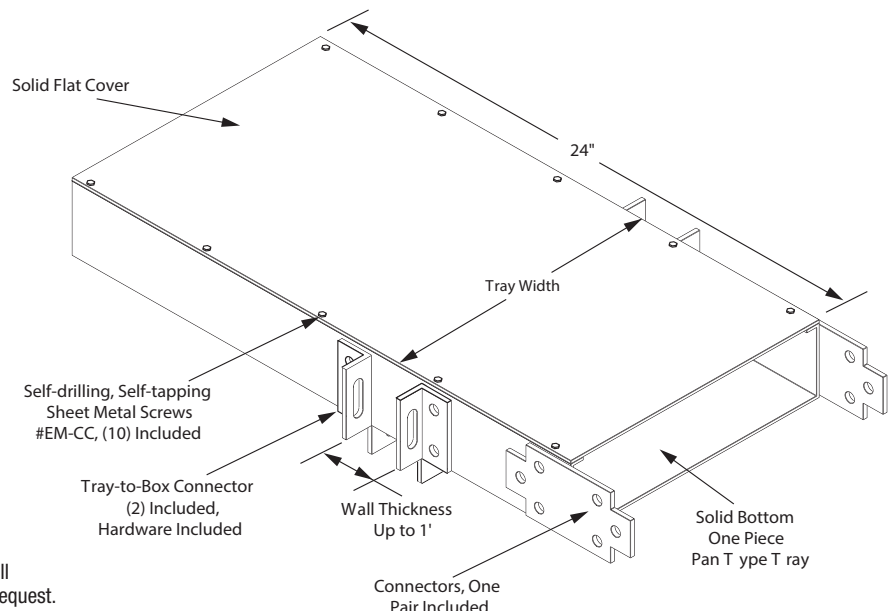

Note: Standard penetration sleeves are manufactured from mill galvanized steel. Aluminum sleeves are available upon request.

BARRIER STRIP

UNIVERSAL ALUMINUM BARRIER STRIP - STRAIGHT SECTION [SB]

CATALOG NUMBER (ALUMINUM)

Part	Load Depth	Basic No. - Length
3A	3"	-01SB-10 - 10'
4A	4"	-01SB-12 - 12'
5A	5"	
6A	6"	
7A	7'	

Example: 4A-01SB-12 for I-Beam 4" load depth, aluminum straight barrier, 12' long.

Furnished with 8 self tapping screws.

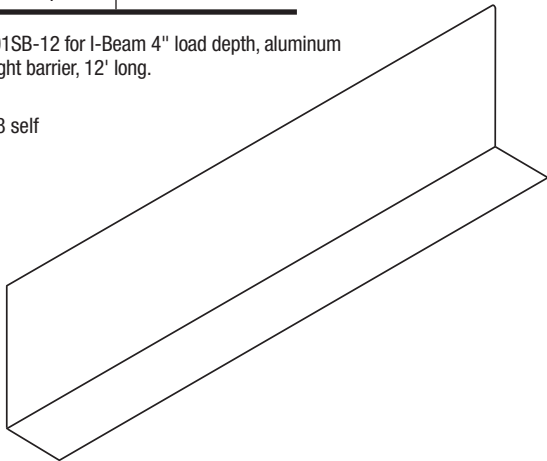

BARRIER STRIP - HORIZONTAL FITTING [FB]

CATALOG NUMBER (ALUMINUM)

Load Depth	Finish (LADDER)	Finish (HAT & TROF)	Basic No. 12' Length
3"	6 (Mill Galv.)	2 (Mill Galv.)	-01FB-06
4"	7 (HDGAF)	3 (HDGAF)	
5"	8 (Alum.)	4 (Alum.)	
6"	T (304SS)	U (304SS)	

Example: 38-01FB-06 for 3" load depth, aluminum fitting barrier, 6' long.

Furnished with 4 barrier strip clamps and necessary hardware.

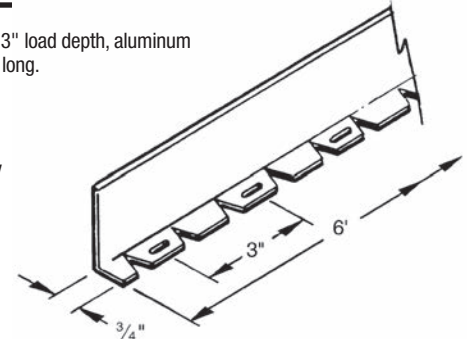

NYLON BARRIER SPLICE & PROTECTOR [BSP]

CATALOG NUMBER

Prefix	Length
	-5 (5" Splice)
BSP	-144 (144" Protector)
	-1200 (100' Roll)

Example: BSP-1200 for 100' roll

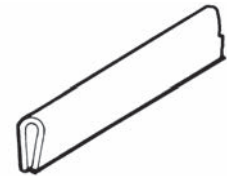

BARRIER STRIP VERTICAL ELBOW OUTSIDE [OB] & INSIDE [IB]

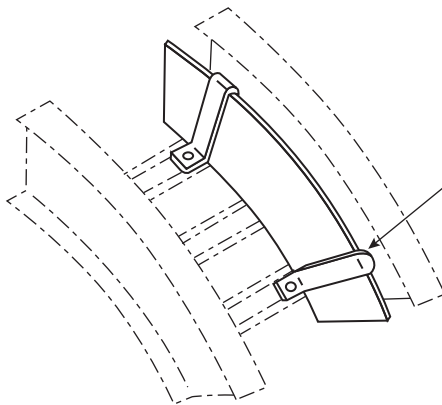

Barrier Strip Clamp
Part No. 50172
Furnished with vertical elbow barriers

CATALOG NUMBER (ALUMINUM)

Part	Load Depth	Bend (deg.)	Basic No.	Radius
3A	3"	90	OB = Outside	12" (305mm)
4A	4"	60	IB = Inside	24" (610mm)
5A	5"	45		36" (914mm)
6A	6"	30		
7A	7'			

Example: 3A-90OB-12 for I-Beam flange, 3" load depth, aluminum 90° outside vertical barrier with 12" radius. (OB Vert. Elbow outside shown) Furnished with sufficient clamp assemblies for installation. Additional clamp assemblies may be ordered separately.

BARRIER STRIP CLAMP (OPTIONAL) [50172]

No. 10 bolt, nut, washer and lock washer furnished.

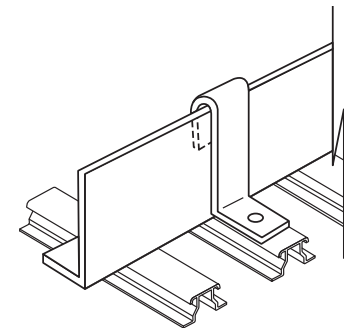

CATALOG NUMBER (ALUMINUM)

Part	Load Depth	Basic No.
H3A	3"	-50172
H4A	4"	
H5A	5"	
H6A	6"	
H7A	7"	

Example: H34-5072 for I-Beam flange, 3" load depth, aluminum clamp.

I-BEAM CABLE TRAY SYSTEM

SUPPORTS

GUSSET-TYPE SUPPORTS

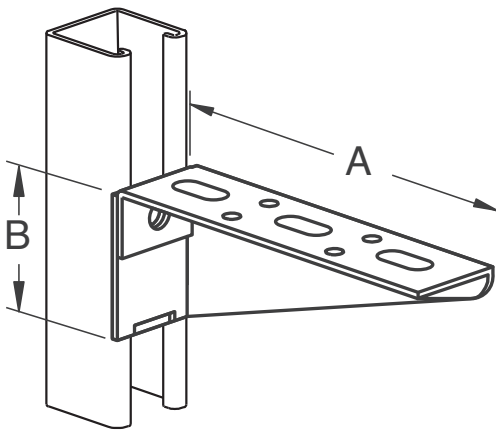

For use with all types of Cope I-Beam systems.
Finish is electro-galvanized.
Order hardware separately.

Catalog No.	I-Beam Width	Dimension		Uniform-Load Rating
		Dim. A	Dim. B	
PS 838R-12	6"	12"	3 7/16"	275 lbs.
PS 838R-16	9"	16"	4 7/16"	275 lbs.
PS 838R-18	12"	18"	4 15/16"	275 lbs.
PS 838R-24	18"	24"	6 7/16"	275 lbs.
PS 838R-30	24"	30"	7 15/16"	275 lbs.

CHANNEL-TYPE SUPPORTS

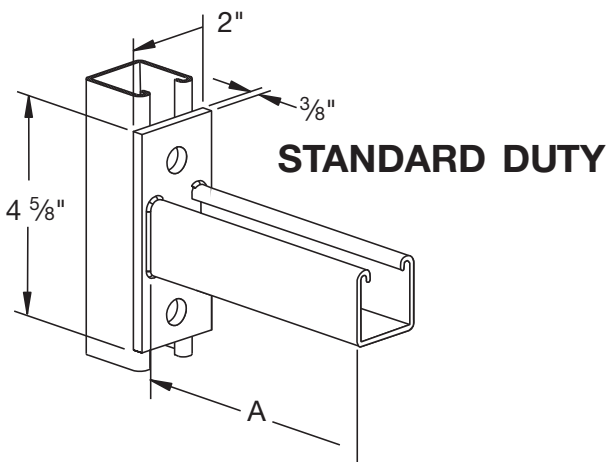

For use with all types of Cope I-Beam systems.
Finish is electro-galvanized.
Order hardware separately.

STANDARD DUTY FOR LIGHTER LOADS

Catalog No.	I-Beam Width	Dimension "A"	Uniform-Load Rating*
PS 651-12	6"	12"	600 lbs.
PS 651-15	9"	15"	480 lbs.
PS 651-18	12"	18"	400 lbs.
PS 651-24	18"	24"	300 lbs.
PS 651-30	24"	30"	240 lbs.

* Mounted on 12 Ga. Channel.

DOUBLE CHANNEL-TYPE SUPPORTS

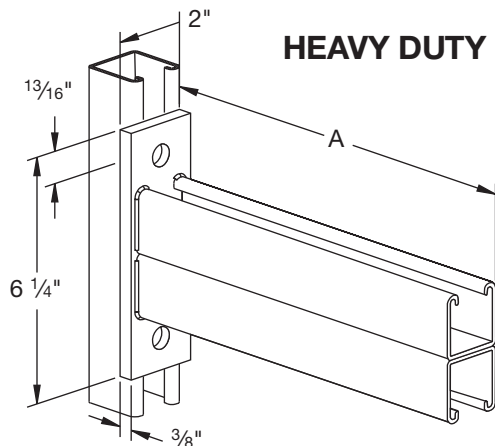

For use with all types of Cope I-Beam systems.
Finish is electro-galvanized.
Order hardware separately.

HEAVY DUTY FOR HEAVIER LOADS

Catalog No.	I-Beam Width	Dimension "A"	Uniform-Load Rating*
PS 809-12	6"	12"	2,000 lbs.
PS 809-15	9"	15"	1,600 lbs.
PS 809-18	12"	18"	1,330 lbs.
PS 809-24	18"	24"	1,000 lbs.
PS 809-30	24"	30"	800 lbs.
PS 809-36	30"	36"	660 lbs.
PS 809-42	36"	42"	570 lbs.

* Mounted on 12 Ga. Channel.

SUPPORT BRACKETS & TRAY HANGERS

WALL SUPPORT BRACKETS

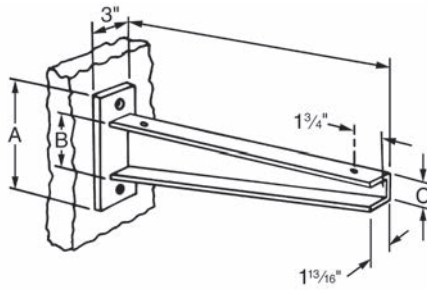

Catalog Number	Ladder Width	Length "L"	Dimensions			End-Load Rating*
			"A"	"B"	"C"	
9037-12	6"	12 1/4"	10"	6"	2"	2000 lbs.
9037-18	12"	18 1/4"	11"	7"	2 1/2"	2000 lbs.
9037-24	18"	24 1/4"	11"	7"	2 1/2"	1600 lbs.
9037-30	24"	30 1/4"	12"	8"	4"	1300 lbs.
9037-36	30"	36 1/4"	12"	8"	4"	1100 lbs.
9037-42	36"	42 1/4"	12"	8"	4"	900 lbs.

*Uniform load rating is normally twice the end-load rating.
Finish is hot-dip galvanized after fabrication.
Order hardware separately

STRUCTURAL SUPPORT BRACKET

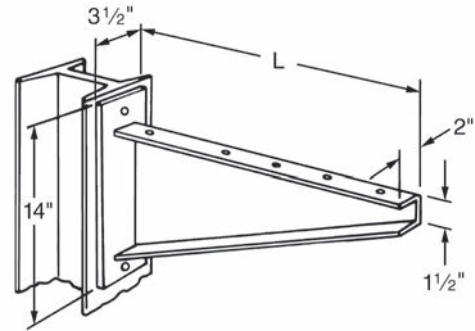

Catalog No.	Ladder Width	Length "L"	End-Load Rating*
9036-31	24"	31 1/4"	2000 lbs.
9036-37	30"	37 1/4"	1800 lbs.
9036-45	36"	45 1/4"	1500 lbs.

*Uniform load rating is normally twice the end-load rating.
For use with Cope I-Beam 24" or wider. May be welded or bolted to building steel.
Finish is hot-dip galvanized after fabrication.
Order hardware separately.

POWER-PIER ROOFTOP SUPPORT SYSTEM

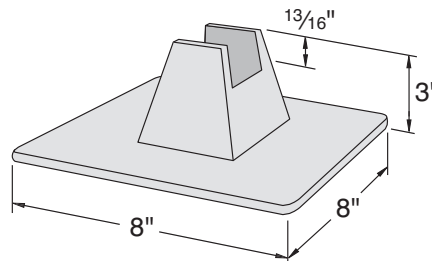

The Power-Pier Rooftop support system provides a simple and versatile way to support and manage pipe, tubing, conduit, HVAC systems, and the like. The Power-Pier system supports without roof surface penetration and allows the parts to remain off the surface

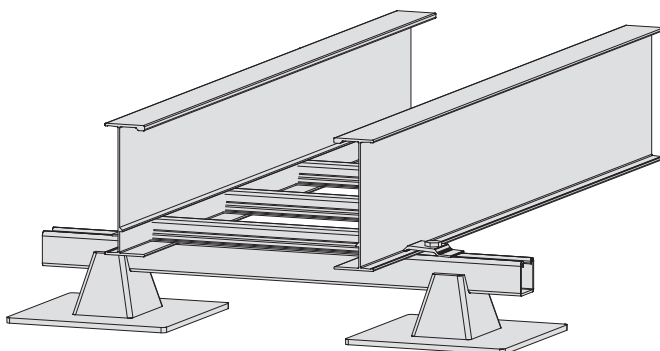

Part Number	Power-Pier Bases Qty.	I-Beam Width	Description
PS PP	4	-	Power-Pier Base Only (4 Bases & Hardware)
PS-SPSS-10HG	4	6"	PS PP + 4 Pcs PS 500 EH HG @ 10" Long for 4" to 8" Pipe
PS-MPDS-13HG	4	9"	PS PP + 2 Pcs PS 200 EH HG @ 13" Long for Trapeze
PS-MPDS-16HG	4	12"	PS PP + 2 Pcs PS 200 EH HG @ 16" Long for Trapeze
PS-MPDS-22HG	4	18"	PS PP + 2 Pcs PS 200 EH HG @ 22" Long for Trapeze
PS-MPDS-28HG	4	24"	PS PP + 2 Pcs PS 200 EH HG @ 28" Long for Trapeze
PS-MPDS-34HG	4	30"	PS PP + 2 Pcs PS 200 EH HG @ 34" Long for Trapeze
PS-MPDS-40HG	4	36"	PS PP + 2 Pcs PS 200 EH HG @ 40" Long for Trapeze

I-BEAM CABLE TRAY SYSTEM

TRAY HANGER & SUPPORTS

SINGLE ROD HANGER SUPPORT

CATALOG NUMBER

Assy. Type	Channel Length*	Channel Finish**	Rod Diameter	Rod Length	Beam Clamp
P200	14" (356mm)	GV (Pre-Galv)	38=3/8" (9.53mm)	000 - No Rod	A - Bridgeport
	17" (432mm)		12=1/2" (12.7mm)	036 - 36" (914mm)	B - P2622
	20" (508mm)	HG (Hot Dipped Galv)		072 - 72" (1828mm)	O - No Clamp
26" (661mm)	120 - 120" (3048mm)		R - Rod Coupler		
32" (813mm)	144 - 144" (3658mm)		S - Special		
38" (966mm)					
	44" (1118mm)				

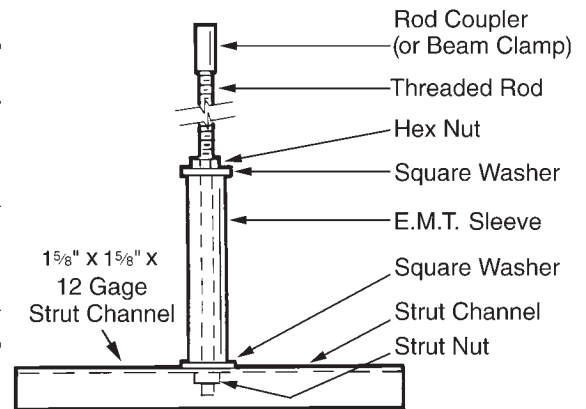

Example: P20020GV12036B is a Single 20" pre-galvanized channel with 1/2" x 36" drop rod and P2622 clamp.

Note:

* Order channel length 8" longer than tray width.

For example, 44" channel for 36" tray.

** Other channel types and finishes available upon request. Contact factory.

To order hardware only:

3/8" - PGV380000

1/2" - PGV120000

TRAPEZE HANGER SUPPORT

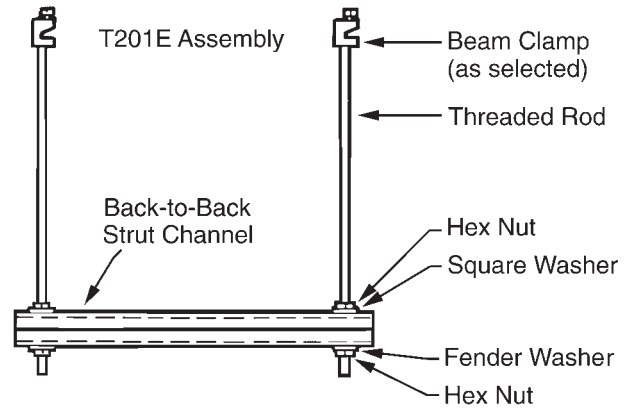
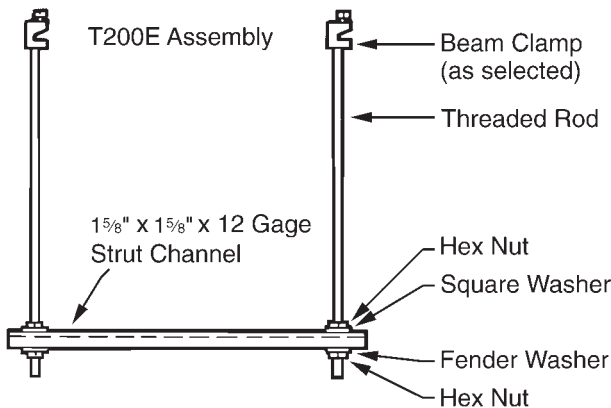

CATALOG NUMBER

Assy. Type	Channel Length*	Channel Finish**	Rod Diameter	Rod Length	Beam Clamp
T200E	16" (407mm)	GV (Pre-Galv)	38=3/8" (9.53mm)	000 - No Rod	A - PS 85
T201E	19" (483mm)	HG (Hot Dipped Galv)	12=1/2" (12.7mm)	036 - 36" (914mm)	B - P2622
	22" (559mm)			072 - 72" (1828mm)	O - No Clamp
	28" (712mm)			120 - 120" (3048mm)	R - Rod Coupler
	34" (864mm)			144 - 144" (3658mm)	S - Special
	40" (1017mm)				
	46" (1169mm)				

Example: T200E22GV12036B is a Single 22" pre-galvanized channel with 1/2" x 36" drop rod and P2622 clamp.

Note:

* Order channel length 10" longer than tray width. For example, 46" channel for 36" tray.

** Other channel types and finishes available upon request. Contact factory.

To order hardware only:

3/8" - PGV380000

1/2" - PGV120000

ELECTRICAL GROUNDING CHART

Fitting Prefix Number		Min. X-Sect for 2 Rails (NEC Table 392.7B) Aluminum I-Beam X-Sect Area	Maximum Ground Fault Amperage (in Amps)Aluminum
System	Load Depth		
5H3A	3"	1.00	1,200
5H4A	4"	1.00	1,200
1H5A	5"	1.50	1,600
5H5A	5"	1.50	1,600
7H5A	5"	2.00	2,000
9H5A	5"	2.00	2,000
7H6A	6"	2.00	2,000
9H6A	6"	2.00	2,000
11H7A	7"	2.00	2,000

The table to the left provides the Minimum Cross Sectional area for two side rails. Using the Fitting Prefix Number (H4A), the proper value is determined by the Material (column 3), the Flange (column 1) and Load Depth (column 2). Locate the line containing the Load Depth (column 1) and follow it to the right to the appropriate Flange and Material.

Find that value in Maximum Ground Fault (column 4), follow it to the right to the Material column to determine the Maximum Ground Fault Amperage.

For Example:

If the fitting prefix is H4A, the Flange is I-Beam, the Load Depth is 4", and the Material is Aluminum. The Minimum Cross Sectional Area (X-Sect Area) is 1.00 sq. in. The Amperage is 1,200.

TYPICAL SPECIFICATIONS

By specifying the NEMA class designation, you will use the simplest, clearest, and most complete method of specification available and automatically incorporate support span in feet, working (allowable) load in pounds per linear foot, a safety factor of 1.5, a concentrated load if present; and, all other design, manufacturing and test standards including electrical continuity.

All you need to do is add the desired load depth, rung spacing, radius of fittings, metal and finish. You may add accessory information pursuant to your project. Here is a typical specification for an outdoor tray system where the working (allowable) load has been determined to be approximately 75 pounds per foot on support spans of 12'-0".

SPECIFICATION ALUMINUM COPE I-BEAM SYSTEM

Cable I-Beam shall be manufactured by a company regularly engaged in the manufacture of metal cable trays and shall be a member of NEMA. Trays shall conform to NEMA Metal Cable Tray Standard Publication VE-1 (latest issue).

- Cable I-Beam shall be NEMA Classification 12B of the widths indicated.
- Material shall be aluminum alloy with side rails and rungs of 6063.
- Finish shall be natural.
- Inside load depth to be NEMA Standard 4".
- Fittings shall be 12" radius for control cables and 24" radius for power cables. (This must be commensurate with the cable manufacturers' recommended minimum bending radius.)
- All top level trays in stacks, and single runs to have raised peaked, aluminum ventilated covers with heavy duty hold down clamps every 3'-0".
- Install expansion connectors, expansion guides, and hold down clamps per NEMA Standard VE-1.
- Where slopes or horizontal bends of trays are not at the Standard NEMA angles, use adjustable connectors. If the angle is too great for cable bending radius, use combinations of fitting and adjustable connectors.
- Separate all cables of different voltages in the same tray using the manufacturer's standard barriers and barrier hold down system.
- The Cable I-Beam system will be used as an equipment grounding conductor.
- To save space fittings shall have 3" tangents. To facilitate field installation use one pair of universal type connector plates for rigid joints.
- Trays shall be Cope Cable I-Beam System Number 5H4A as manufactured by Atkore International.

NOTES

Blank lined area for notes, starting with a thick black header bar.

8



CHANNEL

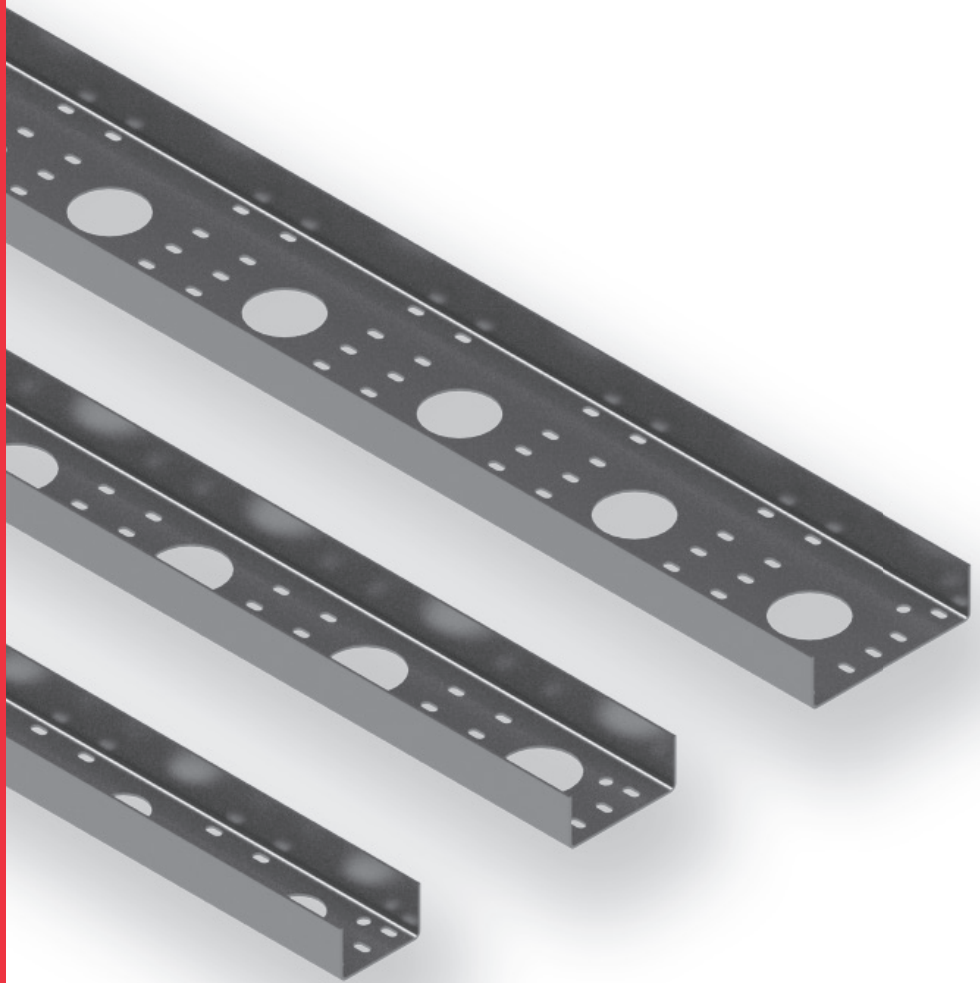

Cable Tray for Branch Power Circuits,
Control, Signal & Tubing Systems.

CHANNEL CABLE TRAY SYSTEM

CONTENTS

GENERAL & TECHNICAL INFORMATION

Pictorial Index.....	153
Straight Length.....	154

COPE CHANNEL FITTINGS

Horizontal Elbows	
90°	155
60°	155
45°.....	155
30°	156
Vertical Elbows (Inside and Outside)	
90°	156
60°	157
45°	157 - 158
30°	158
Horizontal Tee.....	159
Horizontal Cross	159

ACCESSORIES

Blind End	160
End Drop Out.....	160
Nylon Dropout Grommet	160
Channel to Box or Wall Connector	160
Standard Connector.....	160
Expansion Connector	161
Channel Hold Down Clamp	161
Adjustable Horizontal Connector	161
Adjustable Riser Connector	161
Cover Connector	161
Interconnections.....	161
Channel Hangers	162

STRAIGHT LENGTH

Page 154

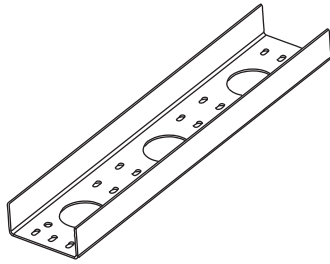

HORIZONTAL CROSS

Page 159

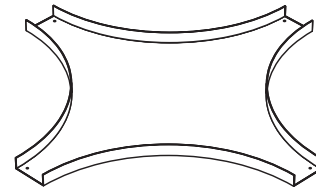

HORIZONTAL ELBOWS

Pages 155 - 156



BARRIER STRIPS & ACCESSORIES

Page 160

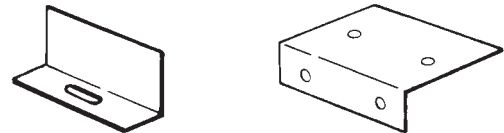

VERTICAL INSIDE ELBOW

Pages 156 - 158

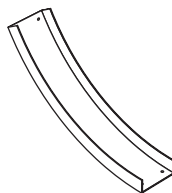

COVER ATTACHMENTS

Page 161

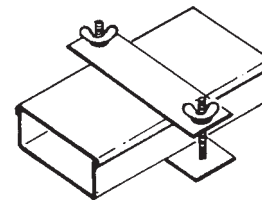

VERTICAL OUTSIDE ELBOW

Pages 156 - 158



ADJUSTABLE CONNECTORS

Page 161

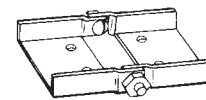

HORIZONTAL TEE

Page 159

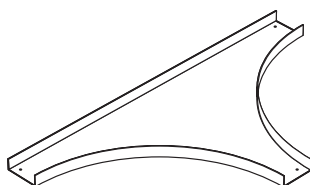

CHANNEL HANGERS

Page 162

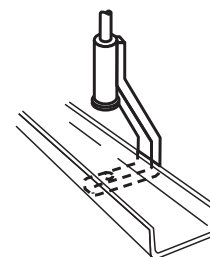

CHANNEL CABLE TRAY SYSTEM

INTRODUCTION

COPE® CHANNEL

Cope Channel supports single branches of power or multiconductor control cable or instrument tubing. Ideal for communication, fire alarm, or call station and clock cabling.

A complete line of devices are available for interfacing with Cope Ladders and Cope Trofs. Compatible with any cable tray system. Cope Channel is more economical than conduit.

Cope Channel is offered in both aluminum and steel, either hot dip mill galvanized (ASTM A 525), or hot dip galvanized after fabrication (ASTM A 386). Covers are available in aluminum and mill galvanized steel. Connectors are furnished with all straight sections and fittings. Other accessories must be ordered separately.

Cope Channel is offered ventilated or solid. Basic units are 3", 4", or 6" wide and are 1³/₄" high. Standard lengths are 12' (3.7m) and 24' (7.4m) long. A load chart is furnished to give you guidance on how often you should support the system. Fitting radii available are 12", 24", and 36". Cope Channel meets NEMA VE-1 standards for cable tray.

ORDERING

For ordering, specify by catalog number using the following prefix to specify the material and finish.

Catalog Number Prefix			
Finish	Straight Sections	Fittings, Accessories & Connectors	Covers
Aluminum	1124	24	FS24
Mill-Galv. Steel	6122	22	FS22
Hot-Dip Galv. Steel	6123	23	--

Loads and Deflection							
Width	Cope Channel Basic No.	8' Span (2.4m)		10' Span (3.0m)		12' Span (3.7m)	
		#/Lin Ft*	Deflection	#/Lin Ft*	Deflection	#/Lin Ft*	Deflection
Aluminum-Plain Finish							
3" (76mm)	1124-03SL	8	.21" (5.3mm)	5	.33" (8.4mm)	3	.40" (10.6mm)
4" (102mm)	1124-04SL	13	.34" (8.6mm)	9	.57" (14.5mm)	6	.79" (20.2mm)
6" (152mm)	1124-06SL	15	.37" (9.4mm)	10	.61" (15.5mm)	6	.76" (19.3mm)
Hot Dip Mill-Galvanized Steel (ASTM A-525)							
3" (76mm)	6122-03SL	8	.13" (3.3mm)	5	.20" (5.1mm)	3	.25" (6.4mm)
4" (102mm)	6122-04SL	13	.21" (5.3mm)	9	.35" (8.9mm)	6	.48" (12.2mm)
6" (152mm)	6122-06SL	15	.23" (5.8mm)	10	.37" (9.4mm)	6	.46" (11.7mm)
Hot Dip Galvanized Steel (ASTM A-386), Covers Mill-Galvanized Only							
3" (76mm)	6123-03SL	8	.13" (3.3mm)	5	.20" (5.1mm)	3	.25" (6.4mm)
4" (102mm)	6123-04SL	13	.21" (5.3mm)	9	.35" (8.9mm)	6	.48" (12.2mm)
6" (152mm)	6123-06SL	15	.23" (5.8mm)	10	.37" (9.4mm)	6	.46" (11.7mm)

Straight Section and Flanged Cover

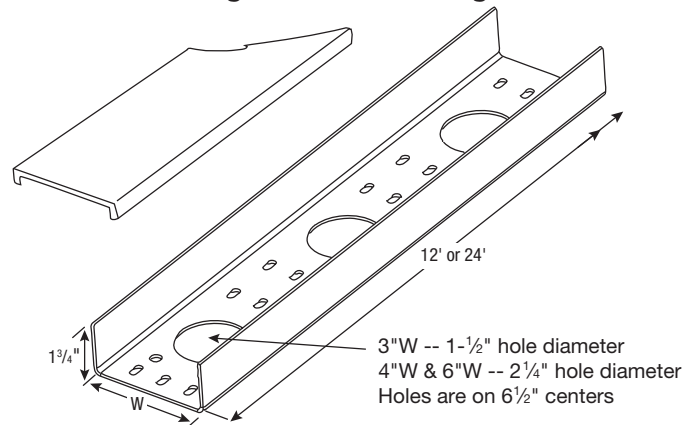

Catalog Number – Straight Section			
Finish	Width	Length	Type
1124 - Alum.	3" (76mm)	SL-12 = 12' (3.65m)	V - Vented
6122 - Mill Galv.	4" (102mm)	SL-24 = 24' (7.3m)	S - Solid
6123 - HDGAF	6" (152mm)		

Example: 1124-04SL-12-V is a 4" wide, vented, 12' aluminum tray.

Catalog Number – Flanged Cover		
Finish	Width	Length
FS24 - Alum.	3" (76mm)	SL-12 = 12' (3.65m)
FS22 - Mill Galv.	4" (102mm)	
	6" (152mm)	

Example: FS24-04SL-12 is a 4" wide, 12' aluminum cover.
NOTE: 24' length not available.

Catalog Number – Flanged Fitting Covers		
Finish	Width/Basic No.	Radius
FS24 - Alum.	-03 XX * (76mm)	12"
FS22 - Mill Galv.	-04 XX * (102mm)	24"
	-06 XX * (152mm)	36"

Example: FS24-034F-12 is a 3" wide, 45° Horizontal Elbow, 12" Radius fitting cover.
* XX from fitting selection base part number

90° HORIZONTAL ELBOW [9F]

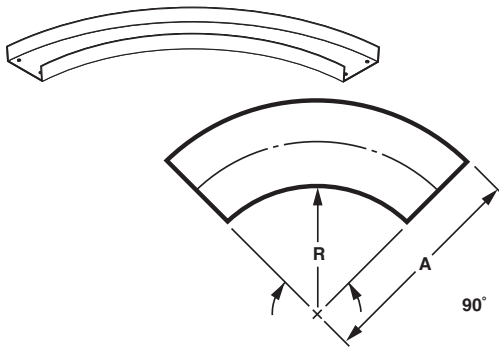

Radius - R	Width - W	"A" Dim.	Part Number
12" (305mm)	3" (76mm)	15" (381mm)	M-039F-12-B
	4" (102mm)	16" (406mm)	M-049F-12-B
	6" (152mm)	18" (457mm)	M-069F-12-B
24" (610mm)	3" (76mm)	17" (432mm)	M-039F-24-B
	4" (102mm)	28" (711mm)	M-049F-24-B
	6" (152mm)	30" (762mm)	M-069F-24-B
36" (914mm)	3" (76mm)	39" (991mm)	M-039F-36-B
	4" (102mm)	40" (1016mm)	M-049F-36-B
	6" (152mm)	42" (1067mm)	M-069F-36-B

60° HORIZONTAL ELBOW [6F]

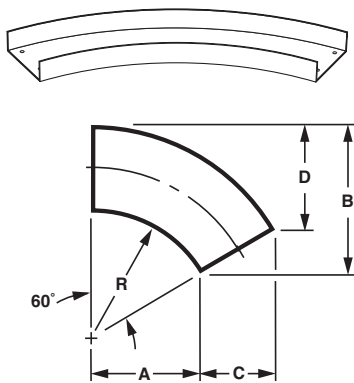

Radius - R	Width - W	"A" Dim.	"B" Dim.	"C" Dim.	"D" Dim.	Part Number
12" (305mm)	3" (76mm)	10 3/8" (264mm)	9" (229mm)	2 5/8" (66mm)	7 1/2" (191mm)	M-039F-12-B
	4" (102mm)	10 3/8" (264mm)	10" (254mm)	3 1/2" (88mm)	8" (203mm)	M-049F-12-B
	6" (152mm)	10 3/8" (264mm)	12" (305mm)	5 1/4" (132mm)	9" (229mm)	M-069F-12-B
24" (610mm)	3" (76mm)	20 3/4" (528mm)	15" (381mm)	2 5/8" (66mm)	13 1/2" (343mm)	M-039F-24-B
	4" (102mm)	20 3/4" (528mm)	16" (406mm)	3 1/2" (88mm)	14 1/2" (356mm)	M-049F-24-B
	6" (152mm)	20 3/4" (528mm)	18" (457mm)	5 1/4" (132mm)	15" (381mm)	M-069F-24-B
36" (914mm)	3" (76mm)	31 1/4" (792mm)	21" (533mm)	2 5/8" (66mm)	19 1/2" (495mm)	M-039F-36-B
	4" (102mm)	31 1/4" (792mm)	22" (559mm)	3 1/2" (88mm)	20" (508mm)	M-049F-36-B
	6" (152mm)	31 1/4" (792mm)	24" (610mm)	5 1/4" (132mm)	21" (553mm)	M-069F-36-B

45° HORIZONTAL ELBOW [4F]

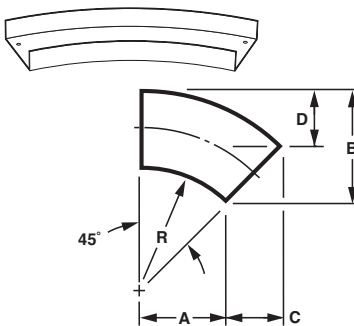

Radius - R	Width - W	"A" Dim.	"B" Dim.	"C" Dim.	"D" Dim.	Part Number
12" (305mm)	3" (76mm)	8 1/2" (216mm)	6 1/2" (165mm)	2 1/8" (54mm)	4 3/8" (112mm)	M-034F-12-B
	4" (102mm)	8 1/2" (216mm)	7 1/2" (191mm)	2 7/8" (71mm)	4 3/4" (119mm)	M-044F-12-B
	6" (152mm)	8 1/2" (216mm)	9 1/2" (241mm)	4 1/4" (108mm)	5 3/4" (134mm)	M-064F-12-B
24" (610mm)	3" (76mm)	17 1/8" (431mm)	10 1/8" (255mm)	2 1/8" (54mm)	7 7/8" (201mm)	M-034F-24-B
	4" (102mm)	17 1/8" (431mm)	11 1/8" (280mm)	2 7/8" (71mm)	8 1/4" (208mm)	M-044F-24-B
	6" (152mm)	17 1/8" (431mm)	13 1/8" (331mm)	4 1/4" (108mm)	8 3/4" (223mm)	M-064F-24-B
36" (914mm)	3" (76mm)	25 1/2" (647mm)	13 5/8" (344mm)	2 1/8" (54mm)	11 1/2" (291mm)	M-034F-36-B
	4" (102mm)	25 1/2" (647mm)	14 5/8" (370mm)	2 7/8" (71mm)	11 3/4" (298mm)	M-044F-36-B
	6" (152mm)	25 1/2" (647mm)	16 5/8" (421mm)	4 1/4" (108mm)	12 3/8" (313mm)	M-064F-36-B

ORDERING INFORMATION

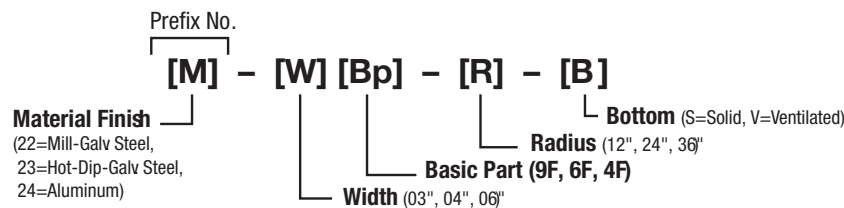

CHANNEL CABLE TRAY SYSTEM

FITTINGS

30° HORIZONTAL ELBOW [3F]

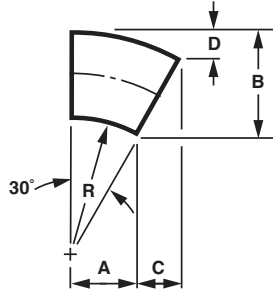

Radius - R	Width - W	"A" Dim.	"B" Dim.	"C" Dim.	"D" Dim.	Part Number
12" (305mm)	3" (76mm)	10 3/8" (264mm)	9" (229mm)	2 5/8" (66mm)	7 1/2" (191mm)	M-039F-12-B
	4" (102mm)	10 3/8" (264mm)	10" (254mm)	3 1/2" (887mm)	8" (203mm)	M-049F-12-B
	6" (152mm)	10 3/8" (264mm)	12" (305mm)	5 1/4" (132mm)	9" (229mm)	M-069F-12-B
24" (610mm)	3" (76mm)	20 3/4" (528mm)	15" (381mm)	2 5/8" (66mm)	13 1/2" (343mm)	M-039F-24-B
	4" (102mm)	20 3/4" (528mm)	16" (406mm)	3 1/2" (88mm)	14 1/2" (356mm)	M-049F-24-B
	6" (152mm)	20 3/4" (528mm)	18" (457mm)	5 1/4" (132mm)	15" (381mm)	M-069F-24-B
36" (914mm)	3" (76mm)	31 1/4" (792mm)	21" (533mm)	2 5/8" (66mm)	19 1/2" (495mm)	M-039F-36-B
	4" (102mm)	31 1/4" (792mm)	22" (559mm)	3 1/2" (88mm)	20" (508mm)	M-049F-36-B
	6" (152mm)	31 1/4" (792mm)	24" (610mm)	5 1/4" (132mm)	21" (553mm)	M-069F-36-B

90° VERTICAL INSIDE ELBOW [9I]

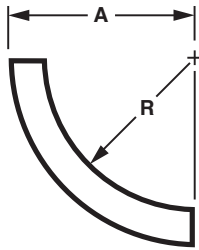
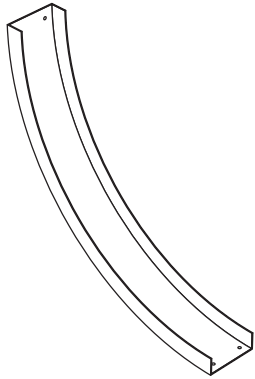

Radius - R	Width - W	"A" Dim.	Part Number
12" (305mm)	3" (76mm)	12" (305mm)	M-039I-12-B
	4" (102mm)	12" (305mm)	M-049I-12-B
	6" (152mm)	12" (305mm)	M-069I-12-B
24" (610mm)	3" (76mm)	24" (610mm)	M-039I-24-B
	4" (102mm)	24" (610mm)	M-049I-24-B
	6" (152mm)	24" (610mm)	M-069I-24-B
36" (914mm)	3" (76mm)	36" (914mm)	M-039I-36-B
	4" (102mm)	36" (914mm)	M-049I-36-B
	6" (152mm)	36" (914mm)	M-069I-36-B

90° VERTICAL OUTSIDE ELBOW [9O]

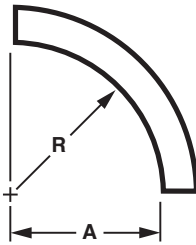
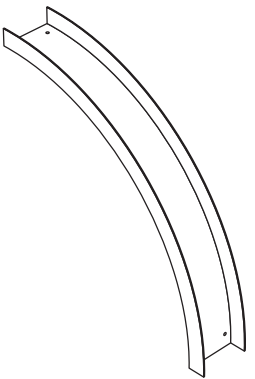

Radius - R	Width - W	"A" Dim.	Part Number
12" (305mm)	3" (76mm)	13 3/4" (349mm)	M-039O-12-B
	4" (102mm)	13 3/4" (349mm)	M-049O-12-B
	6" (152mm)	13 3/4" (349mm)	M-069O-12-B
24" (610mm)	3" (76mm)	25 3/4" (654mm)	M-039O-24-B
	4" (102mm)	25 3/4" (654mm)	M-049O-24-B
	6" (152mm)	25 3/4" (654mm)	M-069O-24-B
36" (914mm)	3" (76mm)	37 3/4" (959mm)	M-039O-36-B
	4" (102mm)	37 3/4" (959mm)	M-049O-36-B
	6" (152mm)	37 3/4" (959mm)	M-069O-36-B

ORDERING INFORMATION

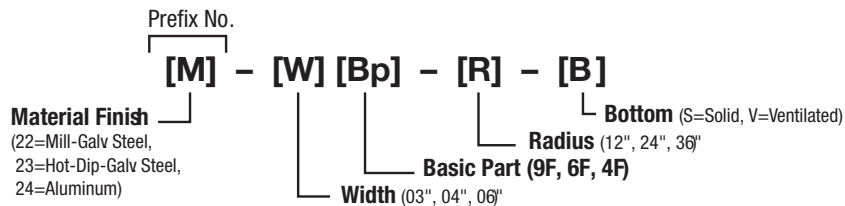

60° VERTICAL INSIDE ELBOW [6I]

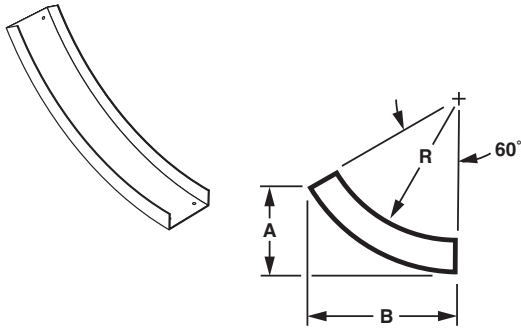

Radius - R	Width - W	"A" Dim.	"B" Dim	Part Number
12" (305mm)	3" (76mm)	6 7/8" (175mm)	11 7/8" (302mm)	M-036I-12-B
	4" (102mm)	6 7/8" (175mm)	11 7/8" (302mm)	M-046I-12-B
	6" (152mm)	6 7/8" (175mm)	11 7/8" (302mm)	M-066I-12-B
24" (610mm)	3" (76mm)	12 7/8" (327mm)	22 1/4" (567mm)	M-036I-24-B
	4" (102mm)	12 7/8" (327mm)	22 1/4" (567mm)	M-046I-24-B
	6" (152mm)	12 7/8" (327mm)	22 1/4" (567mm)	M-066I-24-B
36" (914mm)	3" (76mm)	18 7/8" (479mm)	32 3/4" (830mm)	M-036I-36-B
	4" (102mm)	18 7/8" (479mm)	32 3/4" (830mm)	M-046I-36-B
	6" (152mm)	18 7/8" (479mm)	32 3/4" (830mm)	M-066I-36-B

60° VERTICAL OUTSIDE ELBOW [6O]

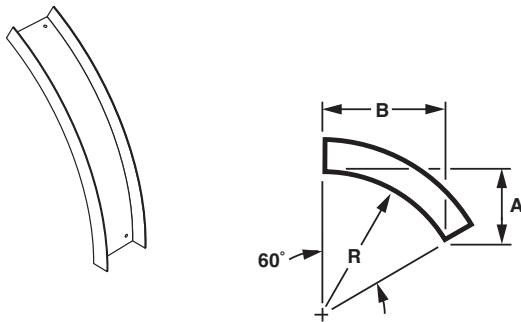

Radius - R	Width - W	"A" Dim.	"B" Dim	Part Number
12" (305mm)	3" (76mm)	6" (152mm)	10 3/8" (264mm)	M-036O-12-B
	4" (102mm)	6" (152mm)	10 3/8" (264mm)	M-046O-12-B
	6" (152mm)	6" (152mm)	10 3/8" (264mm)	M-066O-12-B
24" (610mm)	3" (76mm)	12" (305mm)	20 3/4" (528mm)	M-036O-24-B
	4" (102mm)	12" (305mm)	20 3/4" (528mm)	M-046O-24-B
	6" (152mm)	12" (305mm)	20 3/4" (528mm)	M-066O-24-B
36" (914mm)	3" (76mm)	18" (457mm)	31 1/4" (792mm)	M-036O-36-B
	4" (102mm)	18" (457mm)	31 1/4" (792mm)	M-046O-36-B
	6" (152mm)	18" (457mm)	31 1/4" (792mm)	M-066O-36-B

45° VERTICAL INSIDE ELBOW [4I]

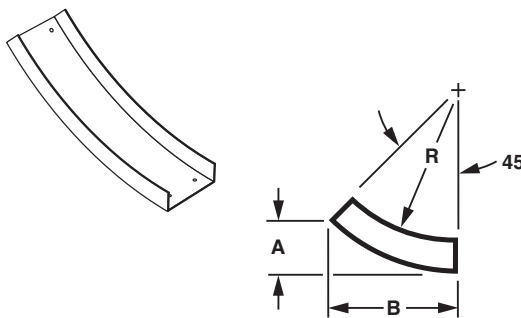

Radius - R	Width - W	"A" Dim.	"B" Dim	Part Number
12" (305mm)	3" (76mm)	4 1/8" (102mm)	9 3/4" (247mm)	M-034I-12-B
	4" (102mm)	4 1/8" (102mm)	9 3/4" (247mm)	M-044I-12-B
	6" (152mm)	4 1/8" (102mm)	9 3/4" (247mm)	M-064I-12-B
24" (610mm)	3" (76mm)	7 1/2" (191mm)	18 1/4" (463mm)	M-034I-24-B
	4" (102mm)	7 1/2" (191mm)	18 1/4" (463mm)	M-044I-24-B
	6" (152mm)	7 1/2" (191mm)	18 1/4" (463mm)	M-064I-24-B
36" (914mm)	3" (76mm)	11 1/8" (281mm)	26 3/4" (678mm)	M-034I-36-B
	4" (102mm)	11 1/8" (281mm)	26 3/4" (678mm)	M-044I-36-B
	6" (152mm)	11 1/8" (281mm)	26 3/4" (678mm)	M-064I-36-B

ORDERING INFORMATION

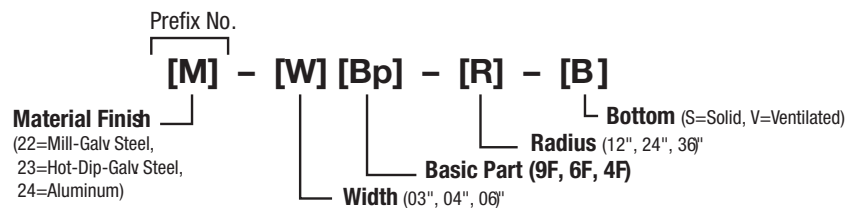

CHANNEL CABLE TRAY SYSTEM

FITTINGS

45° VERTICAL OUTSIDE ELBOW [40]

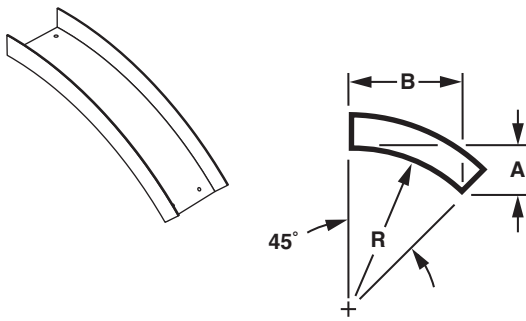

Radius - R	Width - W	"A" Dim.	"B" Dim	Part Number
12" (305mm)	3" (76mm)	3 1/2" (89mm)	8 1/2" (216mm)	M-0340-12-B
	4" (102mm)	3 1/2" (89mm)	8 1/2" (216mm)	M-0440-12-B
	6" (152mm)	3 1/2" (89mm)	8 1/2" (216mm)	M-0640-12-B
24" (610mm)	3" (76mm)	7 1/8" (179mm)	17 1/8" (431mm)	M-0340-24-B
	4" (102mm)	7 1/8" (179mm)	17 1/8" (431mm)	M-0440-24-B
	6" (152mm)	7 1/8" (179mm)	17 1/8" (431mm)	M-0640-24-B
36" (914mm)	3" (76mm)	10 1/2" (268mm)	25 1/8" (646mm)	M-0340-36-B
	4" (102mm)	10 1/2" (268mm)	25 1/8" (646mm)	M-0440-36-B
	6" (152mm)	10 1/2" (268mm)	25 1/8" (646mm)	M-0640-36-B

30° VERTICAL INSIDE ELBOW [31]

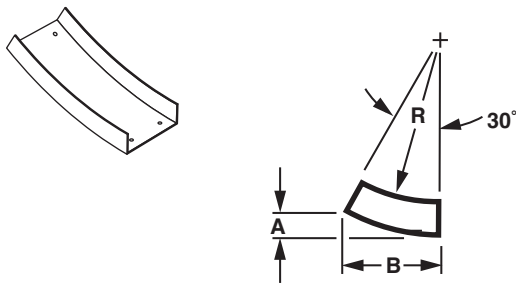

Radius - R	Width - W	"A" Dim.	"B" Dim	Part Number
12" (305mm)	3" (76mm)	1 7/8" (47mm)	6 7/8" (175mm)	M-0331-12-B
	4" (102mm)	1 7/8" (47mm)	6 7/8" (175mm)	M-0431-12-B
	6" (152mm)	1 7/8" (47mm)	6 7/8" (175mm)	M-0631-12-B
24" (610mm)	3" (76mm)	3 1/2" (87mm)	12 7/8" (327mm)	M-0331-24-B
	4" (102mm)	3 1/2" (87mm)	12 7/8" (327mm)	M-0431-24-B
	6" (152mm)	3 1/2" (87mm)	12 7/8" (327mm)	M-0631-24-B
36" (914mm)	3" (76mm)	5 1/8" (129mm)	18 7/8" (479mm)	M-0331-36-B
	4" (102mm)	5 1/8" (129mm)	18 7/8" (479mm)	M-0431-36-B
	6" (152mm)	5 1/8" (129mm)	18 7/8" (479mm)	M-0631-36-B

30° VERTICAL OUTSIDE ELBOW [30]

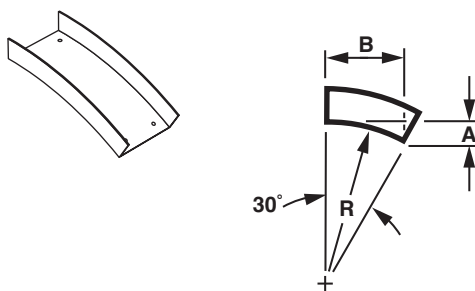

Radius - R	Width - W	"A" Dim.	"B" Dim	Part Number
12" (305mm)	3" (76mm)	1 5/8" (40mm)	6" (152mm)	M-0330-12-B
	4" (102mm)	1 5/8" (40mm)	6" (152mm)	M-0430-12-B
	6" (152mm)	1 5/8" (40mm)	6" (152mm)	M-0630-12-B
24" (610mm)	3" (76mm)	3 1/4" (82mm)	12" (305mm)	M-0330-24-B
	4" (102mm)	3 1/4" (82mm)	12" (305mm)	M-0430-24-B
	6" (152mm)	3 1/4" (82mm)	12" (305mm)	M-0630-24-B
36" (914mm)	3" (76mm)	4 7/8" (122mm)	18" (457mm)	M-0330-36-B
	4" (102mm)	4 7/8" (122mm)	18" (457mm)	M-0430-36-B
	6" (152mm)	4 7/8" (122mm)	18" (457mm)	M-0630-36-B

ORDERING INFORMATION

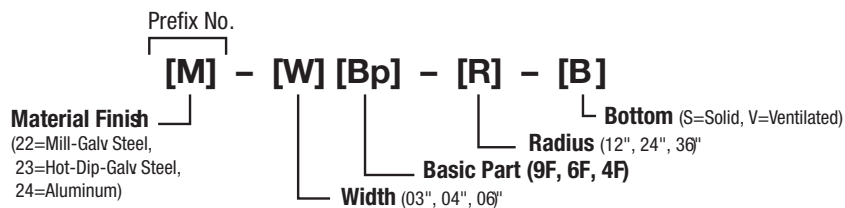

HORIZONTAL TEE [FT]

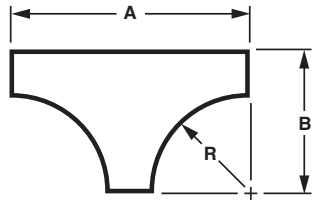
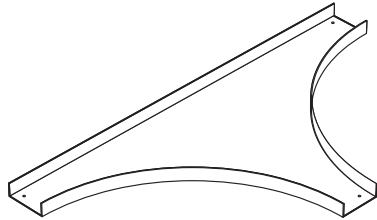

Radius - R	Width - W	"A" Dim.	"B" Dim	Part Number
12" (305mm)	3" (76mm)	27" (686mm)	15" (381mm)	M-03FT-12-B
	4" (102mm)	28" (711mm)	16" (406mm)	M-04FT-12-B
	6" (152mm)	30" (762mm)	18" (457mm)	M-06FT-12-B
24" (610mm)	3" (76mm)	51" (1275mm)	27" (686mm)	M-03FT-24-B
	4" (102mm)	52" (1321mm)	28" (711mm)	M-04FT-24-B
	6" (152mm)	54" (1372mm)	30" (762mm)	M-06FT-24-B
36" (914mm)	3" (76mm)	75" (1905mm)	39" (991mm)	M-03FT-36-B
	4" (102mm)	76" (1930mm)	40" (1016mm)	M-04FT-36-B
	6" (152mm)	78" (1981mm)	42" (1067mm)	M-06FT-36-B

HORIZONTAL TEE [FT]

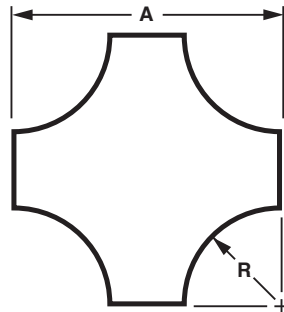
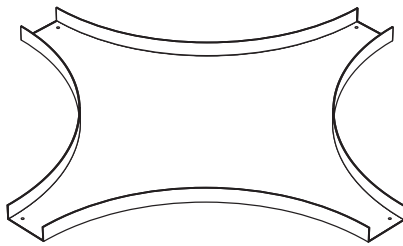

Radius - R	Width - W	"A" Dim.	Part Number
12" (305mm)	3" (76mm)	27" (686mm)	M-03FC-12-B
	4" (102mm)	28" (711mm)	M-04FC-12-B
	6" (152mm)	30" (762mm)	M-06FC-12-B
24" (610mm)	3" (76mm)	51" (1295mm)	M-03FC-24-B
	4" (102mm)	52" (1321mm)	M-04FC-24-B
	6" (152mm)	54" (1372mm)	M-06FC-24-B
36" (914mm)	3" (76mm)	75" (1905mm)	M-03FC-36-B
	4" (102mm)	76" (1930mm)	M-04FC-36-B
	6" (152mm)	78" (1981mm)	M-06FC-36-B

ORDERING INFORMATION

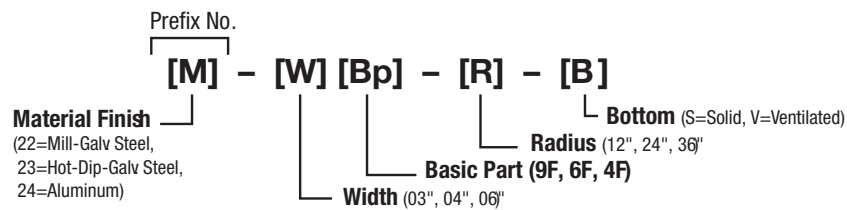

CHANNEL CABLE TRAY SYSTEM

ACCESSORIES

BLIND END [BE]

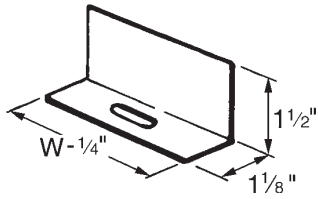

Width - W	Part Number
3" (76mm)	M-03BE
4" (102mm)	M-04BE
6" (152mm)	M-06BE

Steel Plated, Furnished with one set 1/4" x 3/4" bolt, nut and washer.

END DROPOUT [DO]

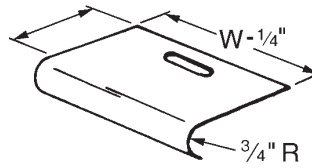

Width - W	Part Number
3" (76mm)	M-03DO
4" (102mm)	M-04DO
6" (152mm)	M-06DO

Prefixes:
 22 = Mill-Galv. Steel,
 23 = Hot-Dip Galv. Steel,
 24 = Aluminum
 Steel plated, Furnished with one set 1/4" x 3/4" bolt, nut and washer.

CHANNEL TO BOX OR WALL CONNECTOR [CB]

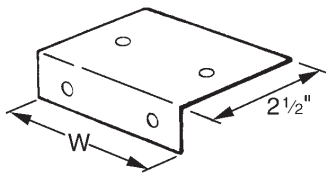

Width - W	Part Number
3" (76mm)	M-03CB
4" (102mm)	M-04CB
6" (152mm)	M-06CB

Prefixes:
 22 = Mill-Galv. Steel,
 23 = Hot-Dip Galv. Steel,
 24 = Aluminum
 Furnished with two sets bolt, nut and washer. Steel plated.

NYLON DROPOUT GROMMET [DOG-1]

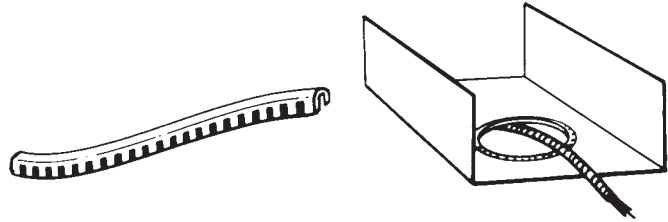

Use at cable dropouts, over sides or thru vent holes.
 Furnished in 12' lengths. Cut to length in field.

STANDARD CONNECTOR [CS]

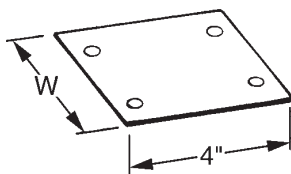

Width - W	Part Number
3" (76mm)	M-03CS
4" (102mm)	M-04CS
6" (152mm)	M-06CS

Prefixes:
 22 = Mill-Galv. Steel,
 23 = Hot-Dip Galv. Steel,
 24 = Aluminum
 Hardware: 3/8" x 3/4" Bolt and flanged nut
 Steel plated incl. (4-sets)

EXPANSION CONNECTOR [CE]

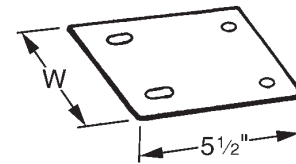

Width - W	Part Number
3" (76mm)	M-03CE
4" (102mm)	M-04CE
6" (152mm)	M-06CE

Prefixes:
 22 = Mill-Galv. Steel,
 23 = Hot-Dip Galv. Steel,
 24 = Aluminum
 Hardware: 3/8" x 3/4" Bolt and flanged nut
 Steel plated incl. (4-sets)

ORDERING INFORMATION

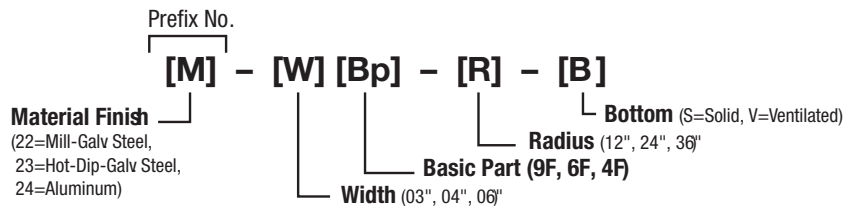

ACCESSORIES, INTERCONNECTIONS

ADJUSTABLE HORIZONTAL CONNECTOR [CH]

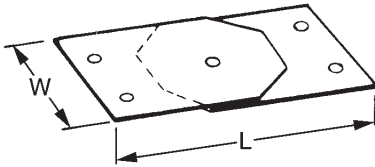

"W" Dimension	"L" Dimension	Part Number
3" (76mm)	7-½" (191mm)	M-03CH
4" (102mm)	8-½" (216mm)	M-04CH
6" (152mm)	10-½" (267mm)	M-06CH

Prefixes:
 22 = Mill-Galv. Steel,
 23 = Hot-Dip Galv. Steel,
 24 = Aluminum
 Hardware: ¼" x ¾" bolt, nut and washer.
 Steel plated incl. (4-sets)

ADJUSTABLE RISER CONNECTOR [CV]

Width - W	Part Number
3" (76mm)	M-03CV
4" (102mm)	M-04CV
6" (152mm)	M-06CV

Prefixes:
 22 = Mill-Galv. Steel,
 23 = Hot-Dip Galv. Steel,
 24 = Aluminum
 Hardware: ¼" x 2¼" Machine screw and wing nut. Steel plated incl. (2-sets)

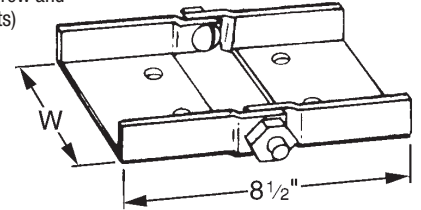

COVER CONNECTOR [CC]

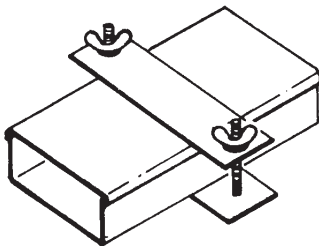

Width - W	Part Number
3" (76mm)	M-03CC
4" (102mm)	M-04CC
6" (152mm)	M-06CC

Prefixes:
 22 = Mill-Galv. Steel,
 23 = Hot-Dip Galv. Steel,
 24 = Aluminum
 Hardware: ⅜" x ¾" Bolt and flanged nut
 Steel plated incl. (4-sets)

CHANNEL HOLDDOWN CLAMP (STAINLESS STEEL)[9079]

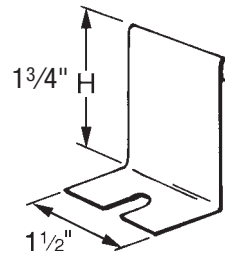

For use with steel or aluminum systems.
 (No hardware included.)

INTERCONNECTIONS

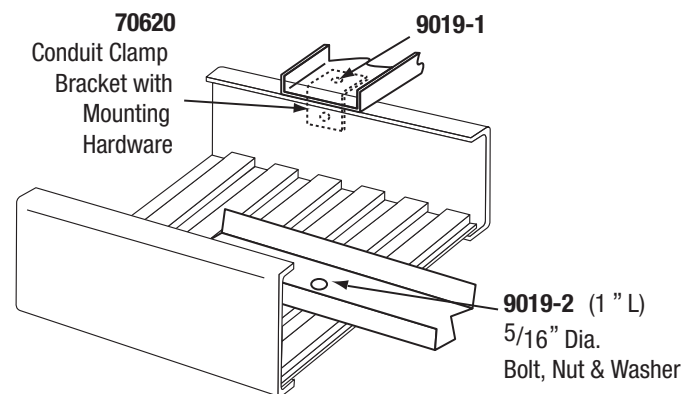
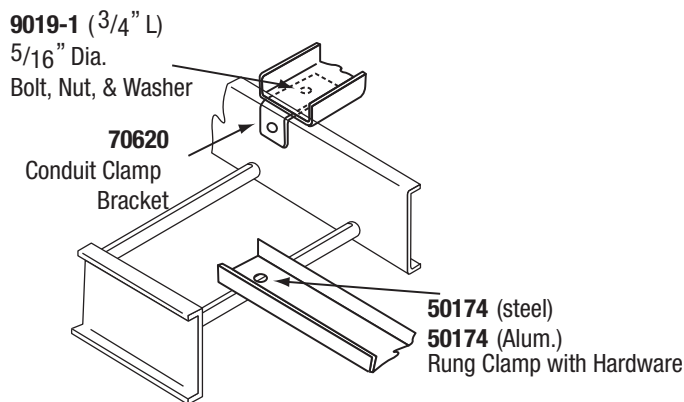

ORDERING INFORMATION

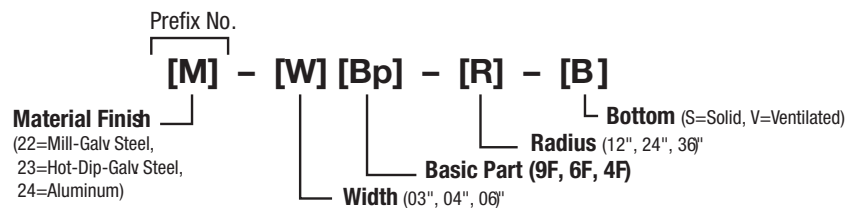

CHANNEL CABLE TRAY SYSTEM

HANGERS

CHANNEL HANGERS

For 3"-, 4"- or 6"- wide Cope Channel raceways. Pipe sleeve accommodates either $\frac{3}{8}$ " or $\frac{1}{2}$ " diameter rods. Finish is hot-dip galvanized after fabrication. Order hardware separately.

Single Channel Hanger	
Catalog No.	Use With
9103	3"- & 4"-wide channel
9013-1	6"-wide channel

Double Channel Hanger		
Catalog No.	Use With	Dimension "A"
9103	3"- & 4"-wide channel	5"
9013-1	6"-wide channel	7"

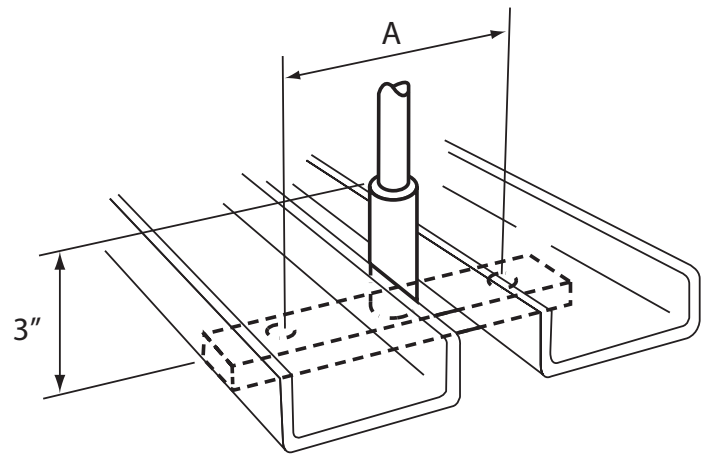
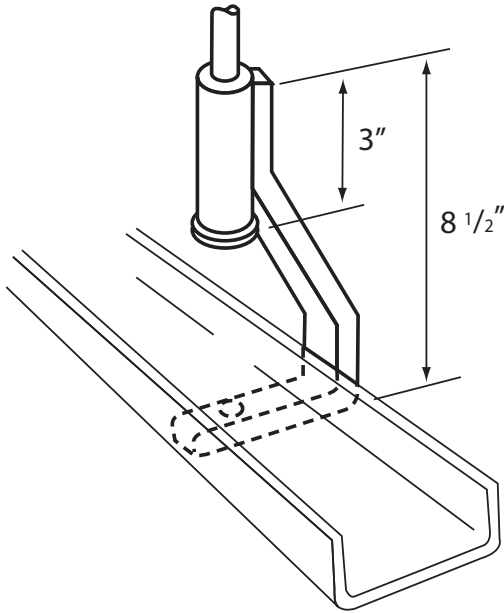

9

COPE-GLAS™

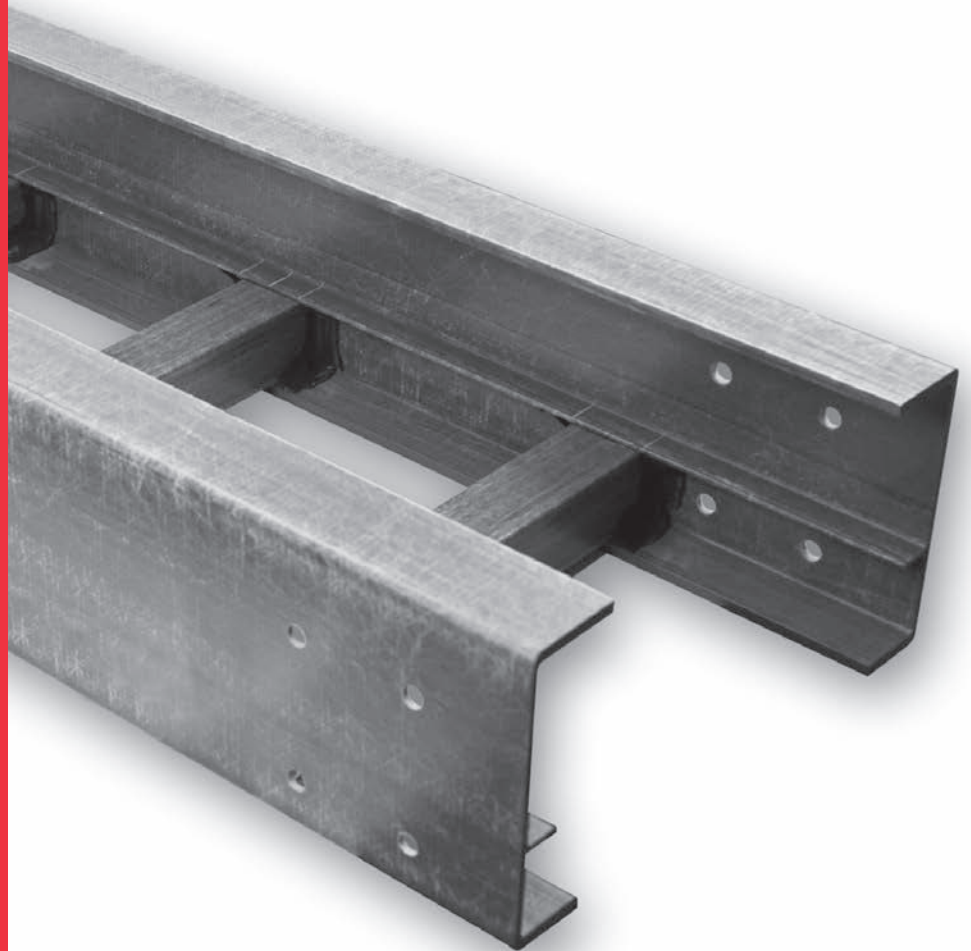

Fiberglass Cable Tray System

CONTENTS

GENERAL & TECHNICAL INFORMATION

Advantages of COPE-GLAS™ Cable Tray	166 - 167
Fiberglass Cable Tray Standards.....	168
COPE-GLAS™ Cable Tray and AICKINSTRUT® Specifications	169

CABLE TRAY DESIGN AND APPLICATION

Construction and Physical Properties.....	170 - 171
Application Environments	172 - 173
COPE-GLAS™ Structural Designs	174
COPE-GLAS™ Selection Guide.....	174
Installation Procedures	175 - 179

PRODUCT INFORMATION

Straight Sections.....	180 - 181
Covers.....	182
Vertical Elbows (Inside and Outside)	
90°	183
45°	184
Adjustable (VAB)	185
Vertical Tee.....	186
Horizontal Elbows	
90°	187
45°	187 - 188
Adjustable (HAB).....	188
Horizontal Tee	189
Horizontal Cross	190
Straight Reducers	191
Left and Right Hand Reducers	191

ACCESSORIES

Splice Plates.....	192 - 194
Accessories.....	194 - 196
AICKINSTRUT® Support Systems.....	197 - 200
COPE-GLAS™ Fiberglass Channel	201 - 203
Additional Related Products.....	204

COPE-GLAS CABLE TRAY IS UL LISTED

Cope-Glas Fiberglass Cable Tray as manufactured by Atkore International is UL listed. This UL Listing guarantees the customer that they will receive a quality product that meets the rigid standards of Underwriters Laboratories. Furthermore, it ensures the customer that the product they receive will meet the required UL and NEMA FG1 performance criteria in the following areas:

- Low Temperature
- High Temperature
- Flame resistance
- Loading & Deflection
- Dielectric Strength
- Volume Resistivity
- Thermogravimetric Analysis
- Infrared Analysis
- UV Exposure
- Water Exposure & Immersion

In order to maintain the UL Listing, Atkore International must continually undergo follow-up testing with Underwriters Laboratories. This further assures the customer that Atkore International is maintaining its quality with respect to raw materials, production and fabrication. This UL Listing demonstrates Atkore International's commitment to developing and providing its customers with the highest quality fiberglass cable tray products available in the industry.

PICTORIAL INDEX

STRAIGHT LENGTH

Pages 180 - 181

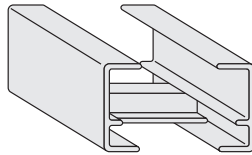

HORIZONTAL CROSS

Page 190

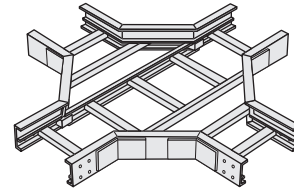

COVERS

Page 182

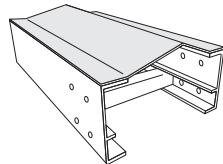

REDUCERS

Page 191

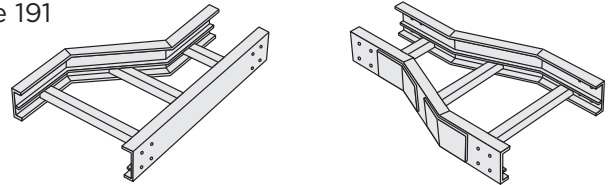

VERTICAL BENDS (INSIDE & OUTSIDE)

Pages 183 - 185

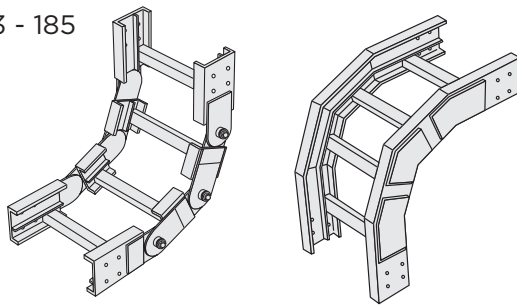

SPLICE PLATES

Pages 192 - 194

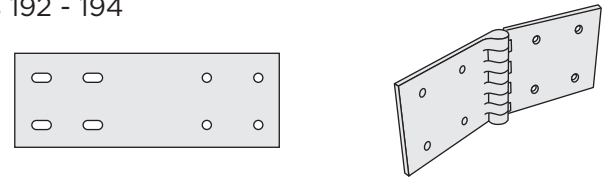

VERTICAL TEES

Page 186

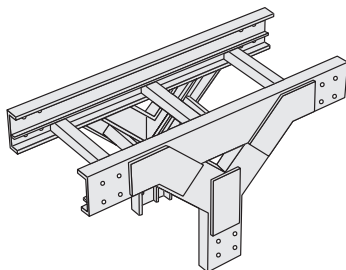

ACCESSORIES

Pages 194 - 196

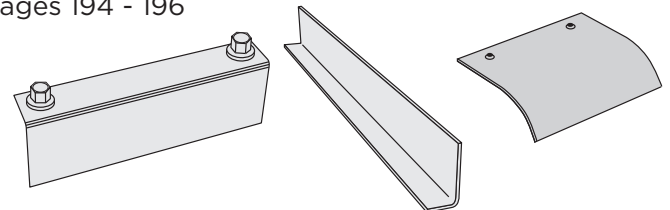

HORIZONTAL ELBOWS

Pages 187 - 188

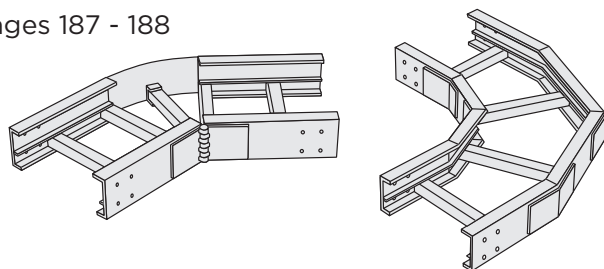

AICKINSTRUT SUPPORT SYSTEM

Pages 197 - 200

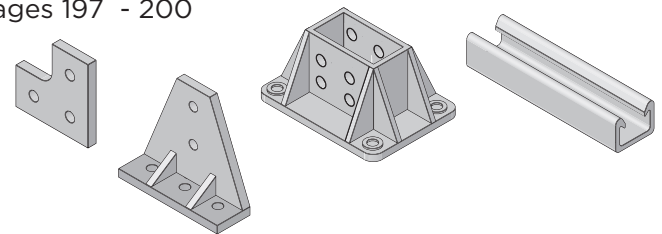

HORIZONTAL TEES

Page 189

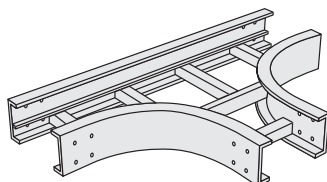

COPE FIBERGLASS CHANNEL SYSTEM

Pages 201 - 203

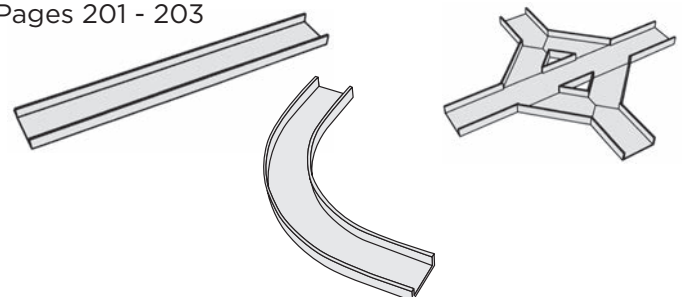

Intro
LADDER
HAT
TROF
HARDWARE
I-BEAM
CHANNEL
COPE-GLAS™
WIRE BASKET
Reference

ADVANTAGES OF COPE-GLAS™ CABLE TRAY

COPE-GLAS™

Systems Advantages

Engineers, designers, contractors, installers and end users have many reasons to choose COPE-GLAS cable tray for their power, signal and control distribution support requirements. Here are some specific advantages that COPE-GLAS systems provide:

Corrosion Resistance

The inherent chemical resistance of COPE-GLAS cable tray makes it desirable for severely corrosive environments. Life cycle costs of tray installations can be dramatically reduced by the extended life expectancy of this product. Many original installations have been in service for nearly fifteen years and are providing reliable service.

Versatile

COPE-GLAS cable tray systems are available in a variety of sizes and styles. A standard or special design can be fabricated for any indoor or outdoor application regardless of size.

Easy Installation

COPE-GLAS cable tray is strong and lightweight, allowing this durable system to be installed quickly and easily. Because there are no sharp edges or burrs, long runs of armored cable can be installed with less chance for cable damage.

Tray System Advantages Over Other Wiring Methods

Cable tray systems in general provide the following advantages over other wiring methods:

Full Ventilation

Power cables need not be derated in a ventilated cable tray system. Explosive gases cannot be trapped or transmitted as in totally enclosed wiring systems.

Long Support Spans

COPE-GLAS cable tray systems are designed for up to twenty foot support spans, longer than most other wiring methods. Fewer supports reduce both installation time and cost.

Installation Labor Reduced

COPE-GLAS cable tray can be installed after concrete and major building steel and mechanical piping are complete. Crews can start later and finish sooner.

Space Efficiency

COPE-GLAS cable tray systems can carry more cable in less space than other wiring methods.

Fully Compatible with Other Wiring Methods

COPE-GLAS cable tray is often used in main runs when other wiring methods are employed in branch circuits.

Simple Field Modifications

Modifications can be made easily using standard metalworking tools without extensive re-engineering.

Accessibility for the Future

New cable can be easily added, replaced or repaired. Circuits can be visually traced, minimizing startup and trouble shooting.

ADVANTAGES OF COPE-GLAS™ CABLE TRAY

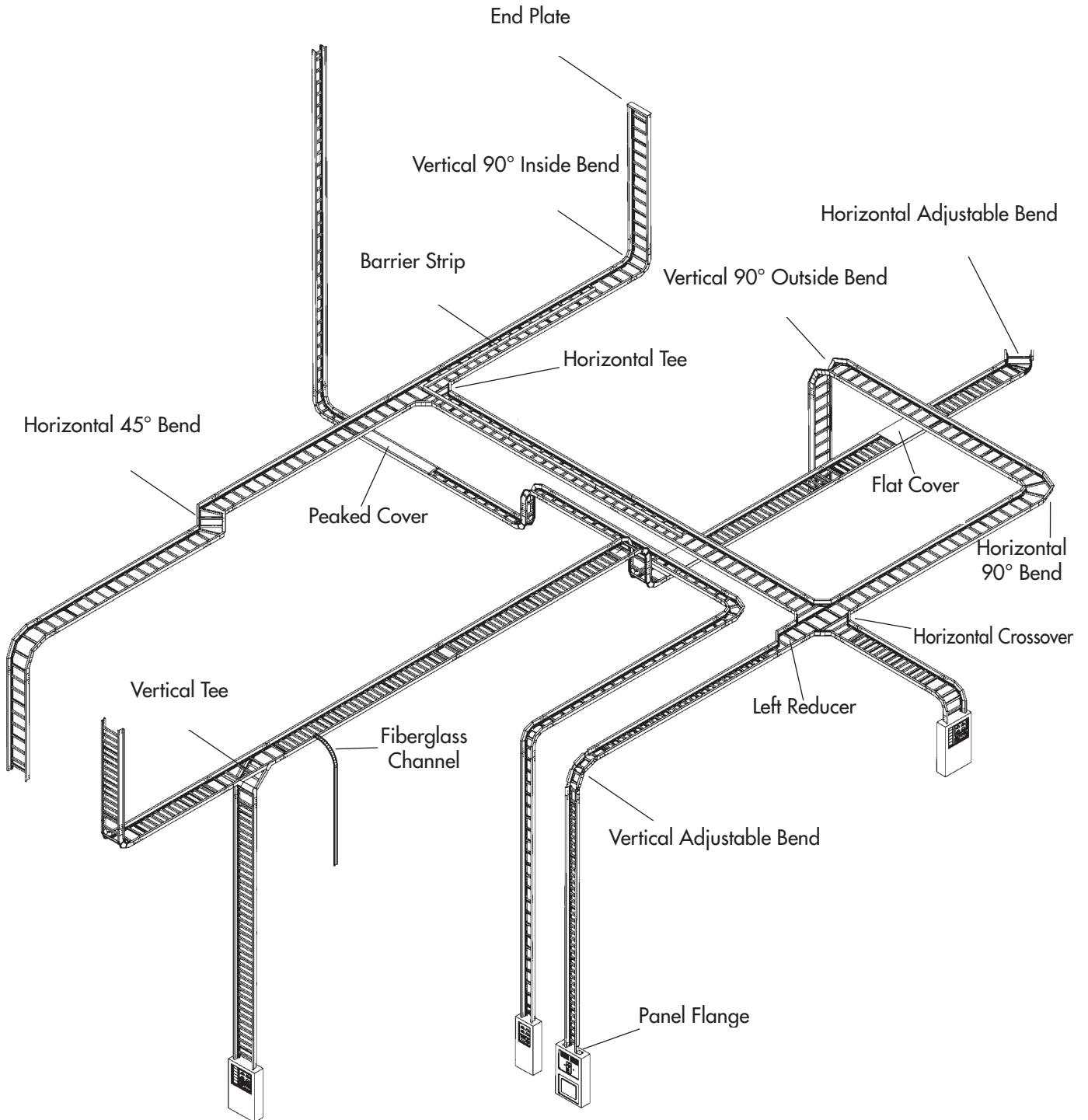

STANDARDS

The standards commonly referenced in specifying cable tray are the National Electric Code®, Article 392-Cable trays; NEMA Standards Publication NO. FG 1, Fiberglass Cable Tray Systems; Canadian Standards Association CAN/CSA-C22.2 No. 126-M91, Cable Tray Systems and Underwriters Laboratories Inc. Standard UL-568, CYOV Non-Metallic Cable Trays. ASTM and UL standards are also referenced to characterize the materials used to construct the fiberglass cable tray.

ASTM standards define physical properties tests for the materials used to pultrude the cable tray. The specific ASTM test methods for mechanical, thermal and flammability properties are identified in the Construction and Physical Properties Section. UL flammability standards applied to fiberglass cable tray materials are also identified in the same section. ASTM and UL standard material properties for fiberglass channel and strut are identical to those of the cable tray because they are pultruded from the same materials.

Load Standards

Section 3 of NEMA FG 1 provides the performance standards and class designations for fiberglass cable tray systems. Based on a twenty foot support span, three working load classifications are recognized:

LOAD STANDARDS

Load Class	Allowable Working Load
A	50 lbs./linear ft.
B	75 lbs./linear ft.
C	100 lbs./linear ft.

COPE-GLAS "Z" Style standard tray is available in one load classification. The standard four inch fill depth cable tray is designated as type "CZ" for the respective NEMA class. The deep tray, which provides six inches of cable fill

depth, is designated as Type "CZD" for its respective NEMA class. The style "E" tray is available in two load classes, which are designated as Type "BE" and Type "CE" for the respective NEMA classes. All COPE-GLAS tray styles have a 1.5 safety factor and exceed the NEMA FG 1 requirement for the allowable working load.

The Low Profile Cable Tray, Type "LC", is not yet included in the NEMA Standard; however, it has been designed and tested to comply with the intent of NEMA FG 1. A safety factor 1.5 times the Type "LC" working load of 50 lbs./linear foot for a 12 foot length has been confirmed by NEMA FG 1 test methods.

Type "LC" cable tray meets the requirements of Class C1 in the CAN/CSA-C22.2 No. 126--M91 standard.

Considerations for Cable Tray Deflection

Cable Tray load testing as specified by NEMA Standard FG 1 requires the test article to be a single length of tray simply supported at each end (referred to as a "simple beam" configuration - see diagram below). This requirement was established to standardize testing and because it is impractical to test large tray system assemblies to destruction. Most actual tray installations consist of multiple lengths of connected tray with multiple supports (referred to as a "continuous beam" configuration). The most significant difference between a continuous versus simple beam configuration is that for continuous beam, the presence of adjacent lengths of tray affect the deflection of the tray in the section of interest.

With the same loading and support span, the maximum deflection is dramatically less for continuous compared to simple beam. For example, in the NEMA FG 1 simple beam test, COPE-GLAS Class CE fiberglass cable tray deflects approximately 3.75" at the mid-point of a 20' support span while carrying its rated load of 100 pounds per foot. In continuous beam, the maximum mid-span deflection would be only 0.8" or 20% of that for simple beam.

Tray Splice Joint Locations vs. Support Locations

In a continuous beam configuration, the bending moment in the tray side rails becomes zero at points located approximately 1/4 of the span from each tray support (referred to as "quarter span points" or just "quarter points"). For example, if the support span is 10 feet, the quarter point is 2.5 feet from the support. Quarter points are ideal locations for spliced tray connections because joints are subjected to minimum bending stresses (see diagram below).

Effect of Temperature

When continuously exposed to elevated temperatures, the strength properties of reinforced fiberglass are reduced. Working loads shall be reduced based on the following table.

EFFECT OF TEMPERATURE

Temp. in °F	Approximate % of Strength	
	Polyester Resin	Vinyl Ester Resin
75°	100	100
100°	90	100
125°	78	100
150°	68	90
175°	60	90
200°	52	75

Note: Consult the manufacturer when temperatures above 200° F are encountered. Cope-Glas™ is not adversely affected by below freezing temperatures.

Chemical Resistance

In most applications, fiberglass cable tray is used because of its superior corrosion resistance; therefore, corrosion resistance data for specific environments are very important. The corrosion resistance guide in the Application Environments Section offers performance data in the most common environments. If information for a specific environment is not shown in the guide, please consult the factory.

Installation/Application

Guidance for cable tray installation, supports and support locations and thermal expansion/ contraction is provided in NEMA FG 1. The installation instructions for supports and support locations contained in the Installation Procedures Section of this catalog are based on the Application Information Section of NEMA FG 1.

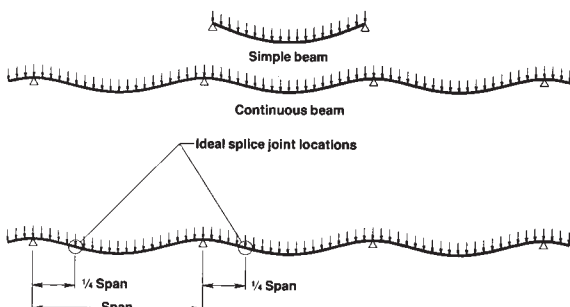

COPE-GLAS™ CABLE TRAY SYSTEM

1. Material

1.1 Cable tray shall be of pultruded glass reinforced polyester or vinyl ester resin having physical property values as listed in the Design and Application Section of this catalog.

2. Composition

2.1 Glass reinforced components shall have a synthetic NEXUS® veil applied on exterior surfaces to improve weatherability and inhibit ultraviolet degradation.* An ultraviolet stabilizer shall be incorporated in the resin formulation to further inhibit ultraviolet degradation.

3. Structural Design

3.1 Cable tray shall be of ladder type design having "E" or "Z" shaped side rails.

3.2 Rungs shall be of the same material as the side rail and shall be secured in place to prevent roll-over when cables are pulled into the tray.

3.3 Cable tray sections shall be 10' or 20' in length (+ or - 1/8"). Each straight section and fitting shall be furnished with pre-punched holes to accept the splice plate fastener.

3.4 Tray system design shall meet or exceed allowable working loads in accordance with the appropriate standard, i.e. NEMA FG 1, CAN/CSA-22.2 No. 126-M91 or UL-568.

3.5 Cable trays shall exceed NEMA FG 1 load requirements.

3.6 The tray loaded to the allowable working load shall be capable of supporting an additional 200 lb. concentrated static load at midspan without failure or permanent deflection.

3.7 Tray system design shall meet all the requirements set forth in Underwriters Laboratories Fiberglass Cable Tray Standard, UL-568. The tray system design shall be tested by UL and be issued the appropriate certified UL listing.

*Due to process limitations, compression molded parts do not incorporate surface veil.

4. General

4.1 Cable trays shall be furnished as a system including all necessary fasteners, hold-down clips, splice plates, support systems, barrier strips, covers, hinged horizontal and vertical splice plates, elbows, reducers, tees, crosses, etc.

4.2 Standard cable tray fittings shall be assembled by the manufacturer. Adjustable fittings may require some field adjustment.

4.3 Splice plate fasteners shall be fiberglass encapsulated stainless steel. Fasteners shall be designed to prevent encroachment of liquids or vapors on the metal threads when fully assembled and tightened. Fasteners must be capable of withstanding a torque of 10 ft./lbs. without damage to the threads of encapsulated coating.

4.4 Manufacturer shall provide certified test data to verify compliance with above loading and deflection data when requested by the purchaser.

4.5 Witness tests may be specified by the customer and shall be scheduled at the time of purchase. Documentation shall also be specified at the time of purchase.

4.6 Special non-standard tests, if requested, shall be specified at the time of purchase.

AICKINSTRUT® SPECIFICATIONS

1. Scope

1.1 This specification covers the requirements for the Aickinstrut Non-Metallic Channel Framing System.

2. Material

2.1 FRP channel shall be of pultruded glass reinforced polyester or vinyl ester resin having the physical property values listed in this catalog.

2.2 PVC channel shall be of extruded polyvinyl chloride having the physical property values listed in this catalog.

2.3 Some accessories shall be of injection molded, 40% long glass fiber reinforced polyurethane, polypropylene or nylon.

3. Composition

3.1 Glass reinforced channel shall have a synthetic surfacing veil applied on exterior surfaces to improve weatherability and inhibit ultraviolet degradation.

3.2 PVC channel shall be manufactured from a UV stabilized resin and incorporate dark gray pigment to improve weatherability and inhibit ultraviolet degradation.

4. Structural Design

4.1 Channel shall incorporate Aickinstrut's flange profile design which allows full and positive

interlocking contact of channel accessories and prohibits premature flange failure from torqued accessories.

4.2 Channel profile dimensions shall be: 158" X 158" X 14", and 112" x 11/8" x 1/8".

4.3 All 158" x 158" channel profiles shall have a minimum pull out resistance of 1000 pounds when load is applied over a 3/8" long section of the inside flanges.

4.4 Channel section lengths shall be supplied in 10' or 20' lengths (+ or -1/8").

4.5 Universal Pipe Clamps shall have full interlocking contact with interior channel flanges to maximize pull-out resistance and be adjustable to accommodate a minimum 3/4" variance in piping or conduit O.D. sizes.

5. Standards

5.1 Glass reinforced and PVC channels covered in this specification shall have a flame spread rating of 25 or less when tested per ASTM E84 and meet the requirements of UL 94V0 thereby qualifying them as Class 1 material in the Uniform Building Code.

5.2 Glass reinforced channels covered in this specification shall comply with

the requirements of ASTM D 3917 and ASTM D 4385 which govern the dimensional tolerances and visual defects of pultruded shapes.

6. General

6.1 Aickinstrut Non-Metallic Framing Channel shall be furnished as a system which includes all the necessary fasteners, channel splice plates, brackets, sealants, hangers, pipe clamps, etc.

6.2 Non-Metallic fasteners shall be manufactured from long glass fiber reinforced polyurethane to ensure maximum strength and corrosion resistance.

6.3 All components of the Aickinstrut Framing System shall be nonmetallic except where 316 stainless steel hardware is used as part of the assembly.

6.4 Aickinstrut® is manufactured by Aickinstrut, a subsidiary of Atkore International, Harvey, IL, 1-800-882-5543.

6.5 The manufacturer shall not have had less than 10 years experience in manufacturing strut systems.

6.6 All products are manufactured in the United States of America.

CONSTRUCTION AND PHYSICAL PROPERTIES

The Pultrusion Process

The pultruded structural component is made by reinforcing a polymer resin (usually polyester or vinyl ester resin) with multiple strands of glass filament and alternating layers of glass mat.

The glass is drawn through the liquid resin, which coats and saturates the fibers. The combination of resin and glass is then continuously guided and pulled (pultruded) through a heated die that determines the shape of the component.

In the die, the resin is cured to form a permanent, reinforced part which can be cut to a specific length. Since the hardened fiberglass pultrusion is reinforced with an internal arrangement of permanently bonded continuous glass fibers, it possesses great strength. In addition to strength, pultruded fiberglass components exhibit exceptional corrosion resistance. This attribute makes fiberglass the material of

choice for many harsh industrial applications.

Resin Systems

Polyester and vinyl ester resin systems are available. The vinyl ester resin system is somewhat stronger and is applied in severe corrosive applications.

Both resin systems are flame retardant, conforming to ASTM E84, Class 1 flame rating and are self extinguishing per the requirements of UL94V-0.

Consult the corrosion resistance guide on pages 190 - 191 to determine the correct resin system for your application.

Low Smoke Resin Systems

Increasingly stringent standards regarding flame retardancy and smoke and fume emissions have necessitated the development of alternatives to standard polyester and vinyl ester resin systems. One of these alternatives, Modified Acrylic Resin (MODAR®), offers

comparable or superior physical/mechanical properties plus low smoke and fume emissions. MODAR® resin cable tray provides the following advantages over polyester and vinyl ester tray:

- Excellent flame retardancy
- Low smoke emissions
- Low levels of toxic combustion products MODAR® cable tray meets the following specifications:

MODAR® CABLE TRAY MEETS THE FOLLOWING SPECIFICATIONS:

Test Method	Result
ASTM E-84	< 25
ASTM E-162	10
radiant panel	@1.5 minutes = 5
ASTM E-662	@4.0 minutes = 50
smoke generation	maximum = 200
UL94	V-0

Contact the factory for additional information regarding pricing and availability.

Typical Properties	Typical Value Test Method	Typical Value			
		Direction	Unit	Polyester	Vinyl Ester
Ultimate Tensile Strength	ASTM D-638	Longitudinal	PSI	30,000	35,000
	ASTM D-638	Transverse	PSI	7,000	10,000
Tensile Modulus	ASTM D-638	Longitudinal	PSI	2.5 x 10 ⁶	3.0 x 10 ⁶
	ASTM D-638	Transverse	PSI	0.8 x 10 ⁶	1.0 x 10 ⁶
Ultimate Compressive Strength	ASTM D-695	Longitudinal	PSI	30,000	w35,000
	ASTM D-695	Transverse	PSI	15,000	20,000
Compressive Modulus	ASTM D-695	Longitudinal	PSI	2.5 x 10 ⁶	2.5 x 10 ⁶
	ASTM D-695	Transverse	PSI	1.0 x 10 ⁶	1.2 x 10 ⁶
Ultimate Flexural Strength	ASTM D-790	Longitudinal	PSI	30,000	35,000
	ASTM D-790	Transverse	PSI	10,000	14,000
Flexural Modulus	ASTM D-790	Longitudinal	PSI	1.6 x 10 ⁶	2.0 x 10 ⁶
	ASTM D-790	Transverse	PSI	0.8 x 10 ⁶	1.0 x 10 ⁶
Shear Strength Short Beam	ASTM D-2344	Longitudinal or	PSI	5,500	7,000
		Transverse	PSI	5,500	6,000
Impact Strength-Izod	ASTM D-256	Longitudinal	ft.-lb./in.	25	30
		Transverse	ft.-lb./in.	4	5
Hardness-Barcol	ASTM D-2583	Perpendicular	50	50	
Electrical					
Electric Strength Short Time-in oil	ASTM D-149	Perpendicular	Volts/mil.	200	200
		Parallel	KV/in.	35	35
Dielectric Constant	ASTM D-150	Perpendicular	5	5	
Dissipation Factor	ASTM D-150	Perpendicular	0.03	0.03	
Arc Resistance	ASTM D-495	Longitudinal or	Seconds	80	120
		Transverse	Seconds	80	120

CONSTRUCTION AND PHYSICAL PROPERTIES

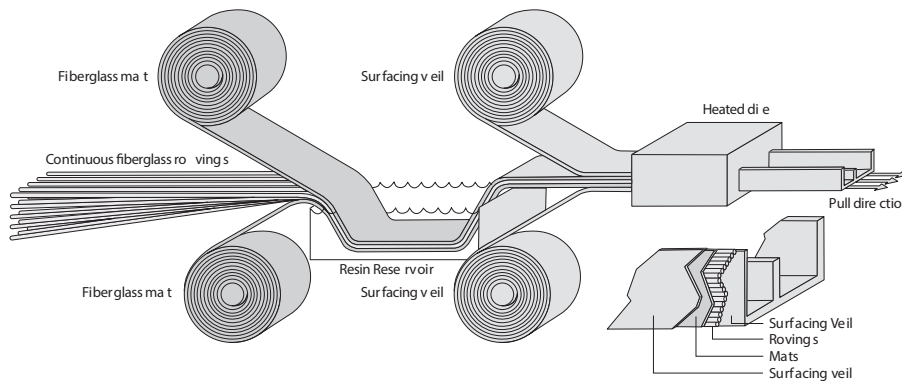

COPE-GLAS Material Properties (Continued from previous page)

Glass Roving and Mat Reinforced Polyester and Vinyl Ester Fiberglass Components

Typical Properties Mechanical	Typical Value Test Method	Typical Value			
		Direction	Unit	Polyester	Vinyl Ester
Other					
Thermal Coefficient of Expansion	ASTM D-696	Longitudinal	in./in./°F	5 x 10 ⁻⁶	5 x 10 ⁻⁶
Thermal Conductivity		Longitudinal	BTU/Hr. sq. ft./in./°F	4	4
Water Absorption 24 hours	ASTM D-570	Longitudinal	%	1	1
Density	ASTM D-792	Longitudinal	lbs./cu.in.	0.062	0.062
Color (Standard)				Dark Gray	Beige
Flammability	UL94		Classification:	V-0	V-0
Flammability	ASTME84		Rating:	25	25

The foregoing list of properties was derived from laboratory data using coupon test specimens cut from pultruded sections. Such information should only be used as a general guide in design. Many actual components (such as cable tray side rail) take advantage of the flexibility of the pultrusion process and are selectively reinforced to enhance performance in a particular load axis. The factory should be contacted for specific information on any given component.

Aickinstruct Fiberglass Threaded Rod Material Properties Threaded rod is a proprietary combination of fiberglass and Class I vinyl ester flame retardant resin.

AICKINSTRUT FIBERGLASS THREADED ROD MATERIAL PROPERTIES

Threaded rod is a proprietary combination of fiberglass and Class I vinyl ester flame retardant resin.

Properties	¾ -16 UNC	½ -13 UNC	⅝ -11 UNC
Thread shear strength using fiberglass nut in tensile (lbs.)	1,250	2,500	3,800
Transverse shear on threaded rod-double shear ASTM-B-565 (load lb.)	4,200	7,400	11,600
Transverse shear on threaded rod-single shear (load lb.)	1,600	2,600	3,800
Compressive strength-longitudinal ASTM-D-695 (psi)	55,000	55,000	55,000
Flexural strength ASTM-D-790 (psi)	60,000	60,000	60,000
Flexural modulus ASTM-D-790 (psi x 10 ⁶)	2.0 x 10 ⁶	2.0 x 10 ⁶	2.0 x 10 ⁶
Torque strength using fiberglass nut lubricated with SAE IOW30 motor oil (ft./lbs.)	8	15	33
Dielectric strength ASTM-D-149 (kv/in.)	40	40	40
Water absorption 24 hour immersion-threaded ASTM-D-570 (%)	1	1	1
Coefficient of thermal expansion-longitudinal (in./in./°F)	5 x 10 ⁻⁶	5 x 10 ⁻⁶	5 x 10 ⁻⁶
Max recommended operation temp, based on 50% retention of ultimate thread shear strength (°F)	200	200	200
Stud weight (lb./ft.)	0.076	0.129	0.209
Flammability	Self extinguishing per UL94V-0		

APPLICATION ENVIRONMENTS

Corrosion Resistance

In most applications COPE-GLAS cable tray is used because of its superior corrosion resistance. The following corrosion resistance guide offers performance recommendations for the most common environments.

Additional data for less common environments are also available from the factory.

Corrosion Resistance Guide

The general guidelines presented in this table take into consideration the normal applications of cable tray products and accessories where exposure to harsh chemicals is limited to fumes or vapors and occasional splashes at ambient temperatures. This information is provided as a guide only since it is impossible to anticipate every conceivable application. For specific applications, which may fall outside the scope of these guidelines, it is recommended that the factory be consulted directly.

Special applications may require a screening test of material samples in the chemical environment of interest.

Notes:

S - indicates satisfactory performance.

NR - indicates not recommended for use. However, acceptable performance may be provided if fumes are not highly concentrated.

NA - indicates information not available.

Chemical Environment	COPE-GLAS Performance	
	Polyester	Vinyl Ester
Acetic Acid	S	S
Acetone	NR	NR
Acrylic Acid	NR	S
Aluminum Chloride	S	S
Aluminum Chlorohydroxide	S	S
Aluminum Citrate	S	S
Aluminum Hydroxide	S	S
Aluminum Nitrate	S	S
Aluminum Potassium Sulfate	S	S
Aluminum Sulfate	S	S
Ammonia, dry gas	S	S
Ammonia, liquid	NR	NR
Ammonium Acetate	NR	S
Ammonium Carbonate	NR	S
Ammonium Chloride	S	S
Ammonium Citrate	S	S
Ammonium Hydroxide	NR	S
Ammonium Nitrate	S	S
Ammonium Phosphate	S	S
Ammonium Sulfate	S	S
Ammonium Sulfide	NR	NA
Ammonium Sulfite	NR	S
Ammonium Thiosulfate	NR	S
Amyl Acetate	NR	NR
Amyl Alcohol	S	S
Amyl Chloride	NR	NA
Aniline Sulfate	S	S
Barium Acetate	S	S
Barium Carbonate	S	S
Barium Chloride	S	S
Barium Sulfate	S	S
Benzene	S	NR
Benzoic Acid	S	S
Benzyl Alcohol	NR	NR
Borax	S	S
Boric Acid	S	S
Brine	S	S
Bromine, dry gas	NR	S
Bromine, wet gas	NR	S
Bromine, liquid	NR	NR
Butyl Acetate	NR	NR
Butyl Alcohol, normal	S	S
Butyl Cellosolve	S	NR
Butylene Glycol	S	S
Butyric Acid	S	S
Calcium Bisulfite	S	S
Calcium Carbonate	S	S
Calcium Chlorate	S	S
Calcium Chloride	S	S
Calcium Nitrate	S	S
Calcium Sulfate	S	S

Chemical Environment	COPE-GLAS Performance	
	Polyester	Vinyl Ester
Caprylic Acid	S	S
Carbon Dioxide, gas	S	S
Carbon Disulfide	NR	NR
Carbonic Acid	S	NA
Carbon Monoxide, gas	S	S
Carbon Tetrachloride	NR	NR
Chloroacetic Acid	NR	S
Chlorinated Paraffin	S	S
Chlorine, dry gas	S	S
Chlorine, wet gas	NR	S
Chlorine, liquid	NR	NR
Chlorine Dioxide	NR	S
Chlorine Water	S	S
Chlorobenzene	NR	NR
Chromic Acid	NR	S
Chromous Sulfate	S	S
Citric Acid	S	S
Coconut Oil	S	S
Copper Acetate	S	S
Copper Chloride	S	S
Copper Cyanide	S	S
Copper Nitrate	S	S
Copper Sulfate	S	S
Cresylic Acid Fumes	NR	NR
Cresol	NR	NA
Crude Oil (Sour)	S	S
Cyclohexane	NR	S
Diallylphthalate	S	S
Diammonium Phosphate	NR	S
Dibutyl Ether	NR	S
Dibutyl Phthalate	S	S
Diesel Fuel	S	S
Diethylene Glycol	S	S
Dimethyl Phthalate	NR	S
Dimethyl Sulfoxide	NR	NA
Diphenyl Ether	NR	S
Dipropylene Glycol	S	S
Esters, Fatty Acid	S	S
Ethyl Alcohol	NR	S
Ethylene Chlorohydrin	NR	S
Ethylene Glycol	S	S
Fatty Acids	S	S
Ferric Chloride	S	S
Ferric Nitrate	S	S
Ferric Sulfate	S	S
Ferrous Chloride	S	S
Ferrous Nitrate	S	S
Ferrous Sulfate	S	S
Fluoboric Acid	S	S
Fluosilicic Acid	NR	S
Formic Acid, vapor	S	S

APPLICATION ENVIRONMENTS

Chemical Environment	COPE-GLAS Performance	
	Polyester	Vinyl Ester
Fuel Oil	S	S
Furfural	NR	NR
Gasoline, Aviation	S	S
Gasoline, Ethyl	S	S
Gluconic Acid	S	S
Glucose	S	S
Glycerine	S	S
Hexachlorocyclopentadienl	NR	NA
Hydrochloric Acid	S	S
Hydrofluoric Acid	NR	
Hydrogen Bromide, dry gas	S	S
Hydrogen Chloride, dry gas	S	S
Hydrogen Chloride, wet gas	S	S
Hydrogen Fluoride, vapor	NR	S
Hydrogen Peroxide	NR	S
Hydrogen Sulfide, dry gas	S	S
Hydrogen Sulfide, wet gas	S	S
Hydroiodic Acid	NR	NA
Hypochlorous Acid	NR	S
sodecanol	S	S
Isopropyl Palmitate	S	S
Jet Fuel (JP-4)	S	S
Kerosene	S	S
Lactic Acid	S	S
Lead Acetate	S	S
Lime Slurry	S	S
Linseed Oil	S	S
Lithium Bromide	S	S
Lithium Chloride	S	S
Magnesium Bicarbonate	S	S
Magnesium Carbonate	S	S
Magnesium Chloride	S	S
Magnesium Nitrate	S	S
Magnesium Sulfate	S	S
Mercuric Chloride	S	S
Mercurous Chloride	S	S
Mercury	S	S
Methyl Alcohol	S	NR
Methyl Ethyl Ketone	NR	NR
Milk Waste	S	S
Mineral Oils	S	S
Monochlorobenzene	NR	NR
Naptha	S	S
Napthalene	S	S
Nickel Chloride	S	S
Nickel Nitrate	S	S
Nickel Sulfate	S	S
Nickel Sulfonate Plating		
Solution	S	S
Nitric Acid	NR	S
Oleic Acid	S	S

Chemical Environment	COPE-GLAS Performance	
	Polyester	Vinyl Ester
Olive Oils	S	S
Oxalic Acid	S	S
Palmitic Acid	S	S
Perchloroethylene	NR	S
Perchloric Acid	NR	S
Phenol	NR	NR
Phosphoric Acid	S	S
Photographic Solutions	S	NA
Phthalic Anhydride	S	S
Pickling Liquids, Acid	S	S
Pickling Liquids, Alkaline	NR	NA
Picric Acids	NR	NA
Potassium Aluminum Sulfate	S	S
Potassium Bicarbonate	S	S
Potassium Bromide	S	S
Potassium Carbonate	NR	S
Potassium Chloride	S	S
Potassium Ferricyanide	S	S
Potassium Ferrocyanide	S	S
Potassium Hydroxide	NR	S
Potassium Nitrate	S	S
Potassium Permanganate	NR	S
Potassium Persulfate	NR	S
Potassium Sulfate	S	S
Propylene Glycol	S	S
Silicic Acid	S	NA
Silver Nitrate	S	S
Sodium Acetate	S	S
Sodium Benzoate	S	S
Sodium Bicarbonate		
Saturated	S	S
Sodium Bisulfate	S	S
Sodium Borate	S	S
Sodium Bromide	S	S
Sodium Carbonate	NR	S
Sodium Chlorate	NR	S
Sodium Chloride	S	S
Sodium Chloride		
Saturated Chlorine	NR	S
Sodium Chlorite	NR	S
Sodium Cyanide	S	S
Sodium Dichromate	NR	S
Sodium Di-phosphate	S	S
Sodium Ferricyanide	S	S
Sodium Ferrocyanide	S	S
Sodium Fluoride	NR	S
Sodium Hydroxide	NR	S
Sodium Hypochlorite	NR	S
Sodium Hyposulfite	S	NA
Sodium Mono-phosphate	S	S
Sodium Nitrate	S	S

Chemical Environment	COPE-GLAS Performance	
	Polyester	Vinyl Ester
Sodium Nitrite	S	S
Sodium Silicate, pH>12	NR	S
Sodium Silicate, pH>12	NR	S
Sodium Sulfate	S	S
Sodium Sulfide	NR	S
Sodium Sulfite	NR	S
Sodium Tetraborate	S	S
Sodium Thiosulfate	S	S
Sodium Xylene Sulfonate	NR	S
Sorbitol Solutions	S	S
Sour Crude Oil	S	S
Soya Oil	S	S
Stannous Chloride	S	S
Stearic Acid	S	S
Styrene	NR	NR
Sulfated Detergents	S	S
Sulfonated Detergents	NR	S
Sulfonyl Chloride, Aromatic	NR	NA
Sulfur Dioxide, dry gas	S	S
Sulfur Dioxide, wet gas	S	S
Sulfuric Acid, vapor	S	S
Sulfurous Acid	NR	S
Tannic Acid	S	S
Tartaric Acid	S	S
Tetrachloroethylene	NR	S
Tetrapotassium Pyrophosphate	NR	S
Tetrasodium Pyrophosphate	NR	S
Toulene	NR	S
Toluene Di-isocyanate fumes	NR	NA
Trichlorethylene, fumes	NR	NR
Trichloroacetic Acid	NR	S
Trimethylamine Hydrochloride	S	S
Triphenyl Phosphite	NR	S
Trisodium Phosphate	NR	S
Turpentine, Pure Gum	NR	S
Urea	S	S
Vinegar	S	S
Water, Cooling Tower	S	S
Water, Demineralized	S	S
Water, Distilled	S	S
Water, Mine	S	S
Water, Sea	S	S
Water, Steam Condensate	S	S
Water, Tap	S	S
Xylene	NR	S
Zinc Chloride	S	S
Zinc Nitrate	S	S
Zinc Sulfate	S	S

STRUCTURAL DESIGNS

COPE-GLAS™ Cable Tray Styles

COPE-GLAS cable tray systems are available in flange-out and flange-in styles. Standard tray, Type CZ and Type CZD deep tray are flange-out designs. Type LC Low Profile tray and standard tray Types BE and CE are flange-in designs.

The "Z" siderail profiles allow for easier cable loading and cover attachment or removal. COPE-GLAS basic "Z" rail profiles provide four inches of cable fill depth and are available in one load classification: CZ.

COPE-GLAS "Deep Z" profile tray, Type CZD, provides six inches of cable fill depth and is only available in NEMA load class "C".

COPE-GLAS Style "E" siderail profiles are flange-in designs that

are especially useful when space is a consideration, such as on closely spaced parallel runs or flush wall mountings. COPE-GLAS "E" rail profile provides four inches of cable fill depth and is available in NEMA load classes "C" as BE and CE.

The Low Profile cable tray, Type LC, is an "E" siderail profile that has a three inch cable loading depth. Type LC cable tray is ideal for control wiring and lighter cable runs that do

not require numerous circuits. All COPE-GLAS cable trays have a 1.5 safety factor that meets the NEMA FG 1 safety factor requirement of 1.5 times the allowable working load.

COPE-GLAS cable tray is also available with a solid bottom upon request. Solid bottom tray consists of a standard ladder tray with a flat fiberglass cover material bonded to the bottom of the tray.

PERFORMANCE STANDARDS AND CLASS DESIGNATIONS

Tray Type	Class	Working Load (20' Span)	Safety Factor
LC Low Profile	A	50 lbs./ft. (12' span)	1.5
BE Standard	C	100 lbs./ft.	1.5
CZ Standard	C+	133 lbs./ft.	1.5
CE Standard	C+	133 lbs./ft.	2
CZD Deep	C+	133 lbs./ft.	1.5

SELECTION GUIDE

Several criteria must be considered in selecting COPE-GLAS cable tray for your application. Factors include load capacity and safety factor; support spans; deflection; cable diameter and tray fill capacity; application environment; space restrictions; fire resistance; future expansion and cost.

Article 392 of the National Electric Code provides cable size and cable fill information. NEMA Standards Publication No. FG 1, Fiberglass Cable Tray Systems, specifies manufacturing standards, performance standards, load class designation specifications and application information such as support span guidelines and temperature deflection information. The following guidelines will assist you in your selection of COPE-GLAS cable tray:

Step 1:

Determine the resin system required based on the application, location, and environment (consult the corrosion resistance guide in the Application Environments section). COPE-GLAS cable tray is available in polyester and vinyl ester resin systems. Vinyl ester provides more corrosion resistance than polyester in some environments.

Step 2 :

Determine tray loading depth and width. Depending on the size and number of cables needed, use the guidelines in NEC Article 392-8 through -12 to determine tray loading depth and width.

Step 3 :

Determine rung spacing. The smallest cable or wire bundle determines the rung spacing for ladder type trays. In general, use eighteen inch rung spacing for 2" O.C. or larger, nine or twelve inch rung spacing for cables from 1" to 2" O.D., six inch run spacing for cables from 12" to 1" O.D. and fiberglass channel type trays for smaller cables.

Step 4 :

Determine the cable load. Calculate in pounds per linear foot the load of the cables to be supported. Consider any extraneous loads such as ice, snow, wind, etc. and add this value to the cable load.

Step 5 :

Determine the tray style. COPE-GLAS offers two side rail configurations; "E" and "Z".

Refer to the Structural Designs section of this catalog to determine tray style.

Step 6 :

Determine the support spacing. Normally, cable tray systems are supported at eight foot to twenty foot intervals. Tray may be supported by wall mount brackets, trapeze suspensions, supports from existing structures or it may be floor mounted to minimize deflection.

Splice joints should be placed at or near the quarter point of the span. This guideline should be rigidly followed and non-compliance granted only after careful engineering analysis because of high cable tray stresses which can be generated.

Step 7:

Determine the NEMA or CSA load class. The cable tray system should be determined by the combination of cable load (Step 4) and support spacing (Step 5). Consult the Structural Design section of this catalog or NEMA FG 1 to assist you in the selection of a tray system that meets your requirements.

NEMA Class	Working Load*
A	50 lbs./lin. ft.
B	75 lbs./lin. ft.
C	100 lbs./lin. ft.

* Working load classifications based on 20 foot support spans. Chart not applicable for channel tray.

INSTALLATION PROCEDURES

The following information shall be used as a guideline for installing COPE-GLAS cable tray.

Special Considerations

With few exceptions, the installation of fiberglass cable tray does not differ from that of metal tray. All standard installation practices and procedures apply. In general, special handling is not required.

Tools Required

Fiberglass tray is easy to cut and drill. For most installations, standard tools are sufficient; however, for large jobs where many sections require cutting and drilling, high speed steel tools may become dull due to the abrasiveness of glass. In such installations, the use of carbide tipped drills and abrasive (grit) saw blades is recommended.

Cutting Tray in the Field

Tray may be easily cut in the field using a standard hacksaw. If some type of power saw is used, abrasive grit-blades work best. When using a power saw, dust filter masks should be worn. Gloves and long sleeve clothing are also recommended.

Sealing Edges

All cut edges should be sealed with FIBER-SEAL, Atkore International's sealant compound. FIBER-SEAL is clear, dries fast and is easy to use. In harsh environments, proper sealing insures against future migration of corrosive elements into the cut sections.

Drilling Holes for Splice Plates

When drilling holes for splice plates, a $\frac{1}{32}$ " drill bit will provide a properly sized hole. Clamp a splice plate (using a C-clamp) to the side of the tray and use this plate as a drilling template. The plate should be positioned to allow a $\frac{1}{16}$ " gap between joined side rails or fittings.

Use of Encapsulated Hardware

Tray sections should be joined using COPEGLAS fiberglass encapsulated stainless steel nuts and bolts (Part #FECNBSS). For maximum protection in extremely harsh environments, apply a generous amount of FIBER-SEAL to the nut and bolt (inside surfaces and threads) just prior to assembly. Assembled splice joints should be tightened to approximately 12 ft/lbs.

Locating Splice Joints

When possible, splice joints should be placed at or near the quarter point of any given support span. This is the point of least

mechanical stress. For example: with a section of tray resting on supports spaced 20 feet apart, the splice plate joints should be located 5 feet from supports (support span divided by 4).

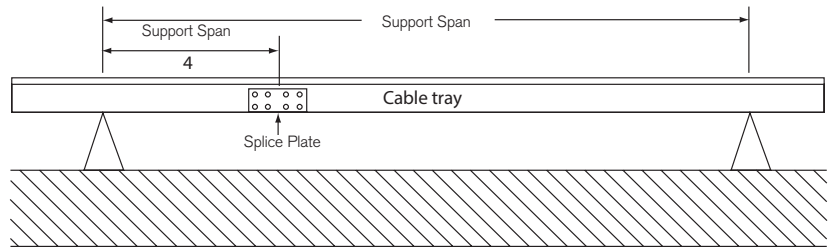

mechanical stress. For example: with a section of tray resting on supports spaced 20 feet apart, the splice plate joints should be located 5 feet from supports (support span divided by 4).

Expansion Splice Plates

Each COPE-GLAS expansion splice plate allows 58" total expansion or contraction under varying temperature conditions. A complete table showing expansion plate placement intervals appears in the COPE-GLAS Accessories section of this catalog.

Clamping & Securing Cable Tray

COPE-GLAS provides a special hold down clamp (Part #HD4AB which

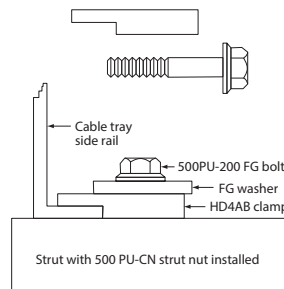

grips the bottom flange of the tray and prevents lateral movement.

This clamp is commonly used to prevent lateral tray movement when long runs rest on I-Beams or other horizontal support members.

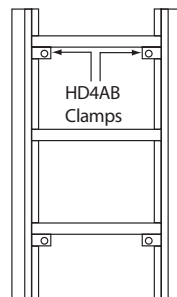

The HD4AB may also be used to secure tray against a vertical wall or bulkhead. In such applications, the clamp should be located adjacent to and below a rung for extra support. When securing tray to a flat vertical bulkhead, it is also acceptable to drill and bolt directly through the bottom flange of the tray. Holes should

be centered in the flange and kept as small as possible ($\frac{3}{8}$ " diameter max).

Wall Brackets

COPE-GLAS fiberglass wall brackets may be used to support cable tray adjacent to a vertical wall. Wall brackets are rated at 750 pounds total weight bearing capacity with a safety factor of 3.0.

Bracket spacing may be determined by dividing 750 lbs. by the tray load (in pounds per foot).

Example: With a cable tray loading of 100 lbs./ft., divide 750 lbs. by 100 lbs./ft. = 7.5 feet. One bracket will be required every 7½ feet.

Tray may be secured to the bracket with HD-4 clamps. Note that the brackets are fabricated using Aickinstrut as the main horizontal support member.

Aickinstrut provides a channel nut (Part #500PU-CN) which fits the interior of the strut. This nut, used in conjunction with a fiberglass bolt (Part #500PU-200), washer (Part #WR500) and HD4AB hold down clamp, forms a complete clamping system. Over-torquing should be avoided (3 ft/lbs max).

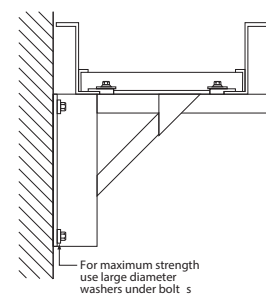

INSTALLATION PROCEDURES

Trapeze Hanging Systems

The fiberglass trapeze hanging system pictured below may be used to support tray in areas where tray cannot be placed on I-beams or other existing structures. Trapeze hangers are assembled in the field using components from this catalog. Care should be taken to configure the hanger as shown.

When properly assembled, the hanger, pictured below, can support 1000 lbs. with a safety factor of 4 (assuming a balanced load). For NEMA Class C Tray rated at 100 lbs./ft., we recommend a minimum of one hanger for every 10 feet of tray (1000 lbs. divided by 100 lbs./ft. = 10 ft.).

As with the fiberglass wall bracket, HD-4 clamps and associated hardware may be used with these Trapeze Systems.

When trapeze hangers are suspended from I-beams using polyurethane beam clamps, it is imperative that the fiberglass all-thread rod be screwed completely into the clamp until it "bottoms out". Achieving full pull out strength requires total thread engagement. Care should be taken not to over torque the rod.

COPE-GLAS Cover Installation Procedure

Nylon Drive Rivets (Part #NDR1) are the most economical method to fasten cable tray covers, but they require 1/4" field drilled holes on 24" centers along both siderails.

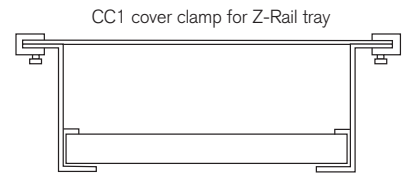

CCE wrap around cover clamp for Low Profile and E-Rail trays

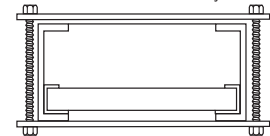

If cover removal or high winds are a concern, either the CC1 or CCE cover clamp may be desired. The CC1 clamp is designed for use on "Z" Style siderail tray and fittings. This PVC coated steel cover clamp requires no field drilling and is easily removed to allow ready access to the inside tray and cables. Six CC1 clamps are recommended for each ten foot length of cable tray cover. The CCE clamp is designed for use with flat cover on Low Profile and "E" Style siderail trays and fittings. The CCE clamp is constructed entirely of fiberglass components and is available in either polyester or vinyl ester resin. Two CCE clamps are recommended for each ten foot length of cable tray cover.

Cover stand-off SO 200

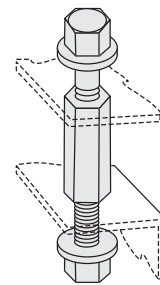

Cover stand-offs secure cable tray cover while providing a ventilation gap for cables. The SO200 requires field drilling. Five pairs of clamps are recommended per ten foot length of cable tray cover.

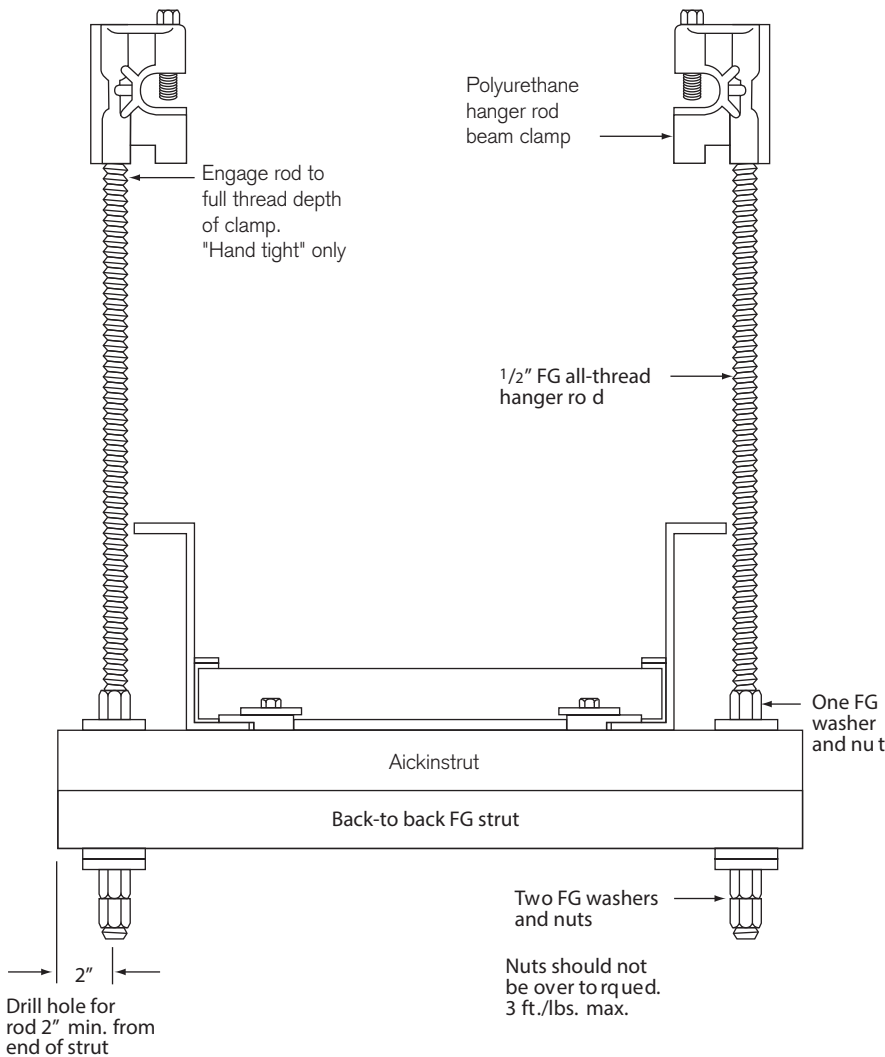

INSTALLATION PROCEDURES

Installation Guidelines:
Fiberglass Trapeze Hanging Systems

The COPE-GLAS cable tray system

offers three types of fiberglass trapeze hanging systems: back to back strut trapeze, single strut with open end down trapeze,

and single strut with open end up trapeze. The specifications associated with each trapeze type are shown below.

Back-to-Back Bonded Strut

1. Fiberglass nuts should not be over-torqued. A snug 3 to 4 ft./lbs. is sufficient.
2. When supporting a 100 lb./ft. load, the spacing between each trapeze should not exceed ten feet. Under these conditions, each trapeze will be supporting 1000 lbs., thus yielding a support system safety factor of 2.
3. When using beam clamps, only COPE-GLAS RGBC series clamps are acceptable. This clamp provides more thread engagement than clamps designed for steel rod and load ratings are dependent on the extra thread engagement. Care should be taken to insure that the rod is fully engaged in the clamp nut, but not over torqued (5 ft./lbs. max.).
4. Material being supported should “fit” the trapeze system as closely as possible. The spacing between the all-thread rod and the material being supported should not exceed 1”.

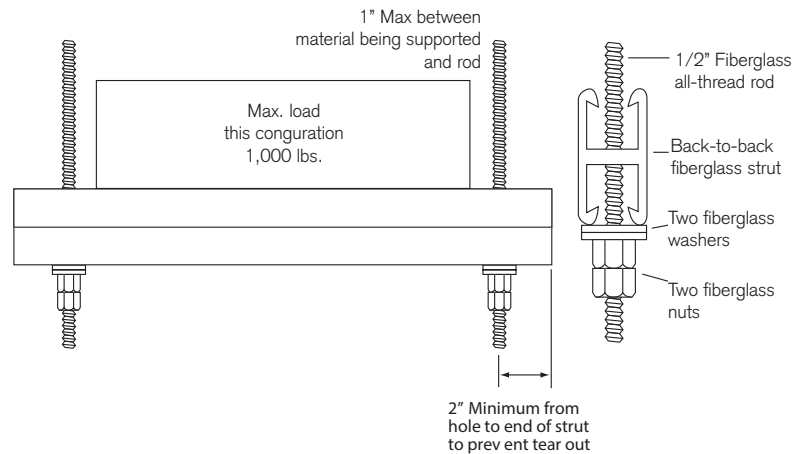

Single Strut With Open End Down

1. When supporting a 100 lb./ft. load, the spacing between each trapeze should not exceed five feet. Under these conditions, each trapeze will be supporting 500 lbs., thus yielding a support system safety factor of 2.
2. When using beam clamps, only COPE-GLAS RGBC series clamps are acceptable. This clamp provides more thread engagement than clamps designed for steel rod and load ratings are dependent on the extra thread engagement. Care should be taken to insure that the rod is fully engaged in the clamp nut, but not over torqued (5 ft./lbs. max.).
3. Material being supported should “fit” the trapeze system as closely as possible. The spacing between the all-thread rod and the material being supported should not exceed 1”.

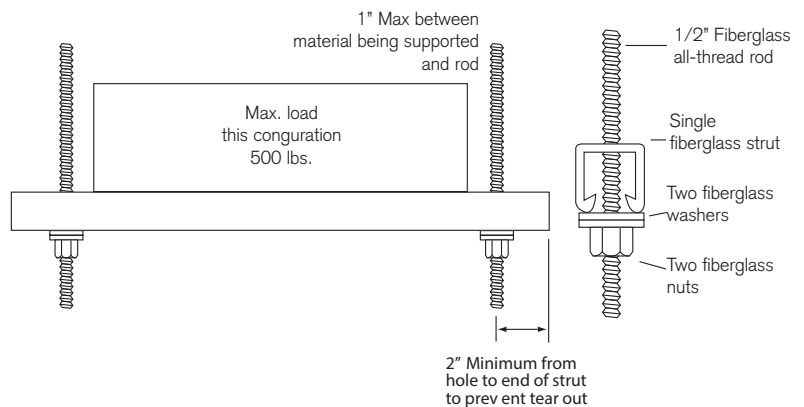

Single Strut With Open-End Up

1. To maintain a safety factor of 2, the load for this configuration should not exceed 400 lbs.
2. When using beam clamps, only COPE-GLAS RGBC series clamps are acceptable. This clamp provides more thread engagement than clamps designed for steel rod and load ratings are dependent on the extra thread engagement. Care should be taken to insure that the rod is fully engaged in the clamp nut, but not over-torqued (5 ft./lbs. max.).
3. Material being supported should “fit” the trapeze system as closely as possible. The spacing between the all-thread rod and the material being supported should not exceed 1”.

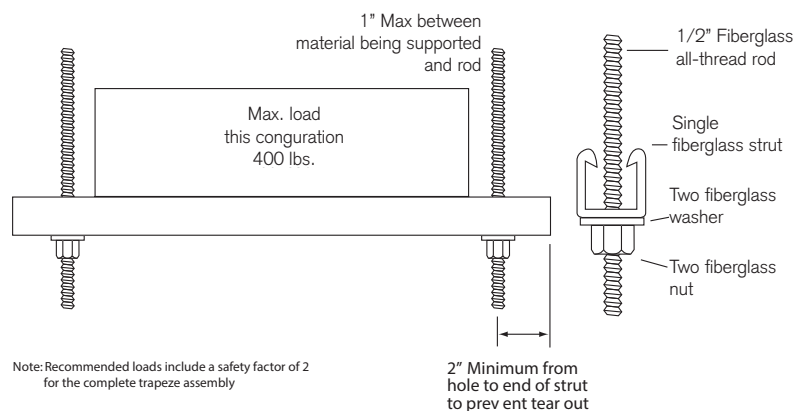

Note: Recommended loads include a safety factor of 2 for the complete trapeze assembly

INSTALLATION PROCEDURES

Aickinstrut® Strut Loading

Aickinstrut is used to hang loads from ceilings where it is common practice to use pipe straps or strut nuts to fasten the loads. The limiting factor in such loading applications is the strength of the non-metallic pipe clamp. Guidelines for these applications are shown at right.

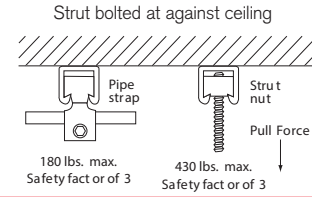

Fiberglass Strut Recommended Loads

(Based on a Safety Factor of 3)

Aickinstrut Light Duty*

1 1/2" x 1 1/8"

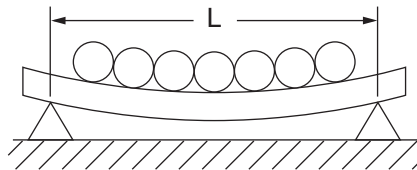
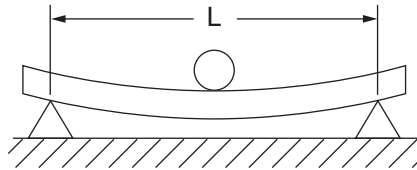

CONCENTRATED LOAD

L	Max. Load	Deflection
2'	407 lbs.	0.48"
3'	271 lbs.	1.08"
4'	203 lbs.	1.92"
5'	163 lbs.	3.01"

DISTRIBUTED LOAD

L	Max. Load	Deflection
2'	815 lbs.	0.605"
3'	543 lbs.	1.36"
4'	407 lbs.	2.41"
5'	326 lbs.	3.77"

Aickinstrut Heavy Duty*

1 5/8" x 1 5/8"

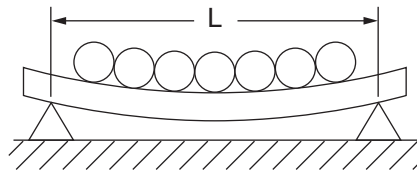
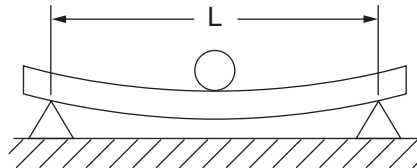
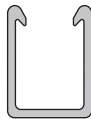

CONCENTRATED LOAD

L	Max. Load	Deflection
2'	890 lbs.	0.328"
3'	593 lbs.	0.737"
4'	445 lbs.	1.304"
5'	356 lbs.	2.04"

DISTRIBUTED LOAD

L	Max. Load	Deflection
2'	1781 lbs.	0.410"
3'	1187 lbs.	0.922"
4'	890 lbs.	1.63"
5'	712 lbs.	2.56"

Aickinstrut Heavy Duty Strut bolted at against ceiling*

3 1/4" x 1 5/8"

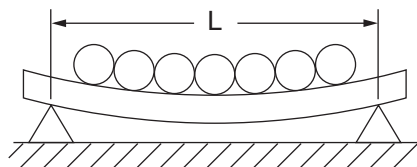
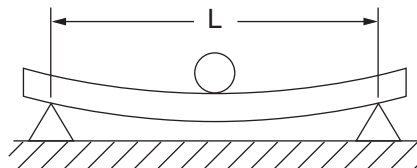
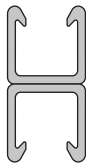

CONCENTRATED LOAD

L	Max. Load	Deflection
2'	1390 lbs.	0.09"
3'	926 lbs.	0.203"
4'	695 lbs.	0.361"
5'	556 lbs.	0.566"

DISTRIBUTED LOAD

L	Max. Load	Deflection
2'	2780 lbs.	0.113"
3'	1853 lbs.	0.254"
4'	1390 lbs.	0.452"
5'	1112 lbs.	0.707"

* See Aickinstrut catalog for part numbers

INSTALLATION PROCEDURES

COPE-GLAS Fiberglass Components and Associated Hardware Loads

The maximum recommended loads and associated safety factors of various fiberglass components are shown here. The recommended support locations for the cable tray fittings are shown below.

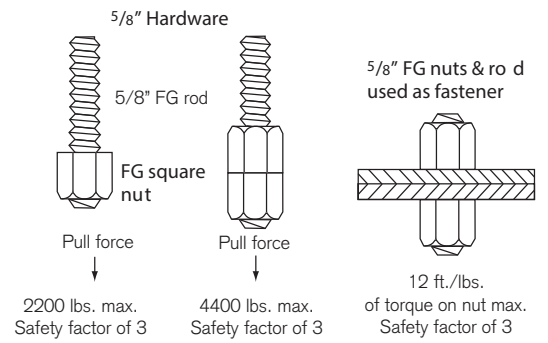
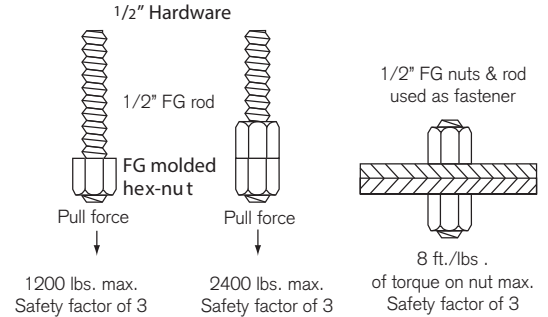
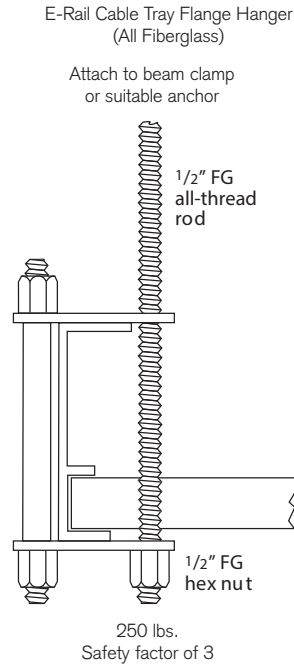
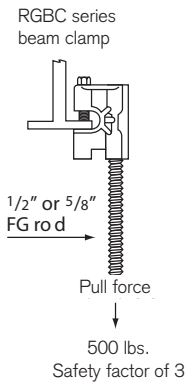

Support Locations for Cable Tray Fittings

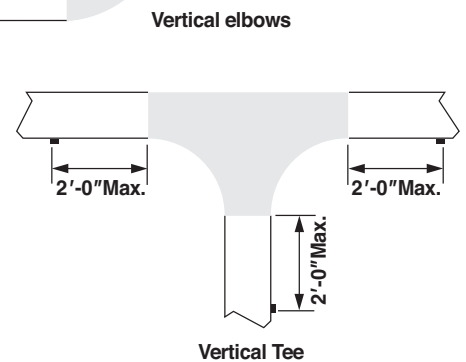
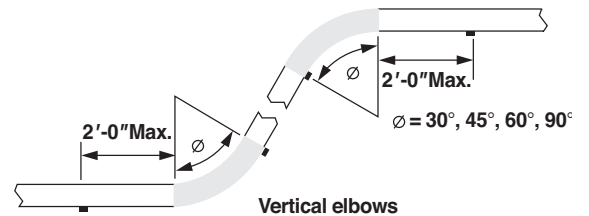
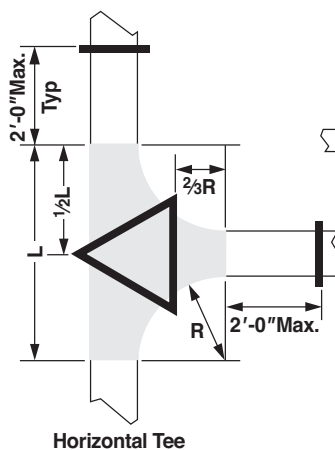
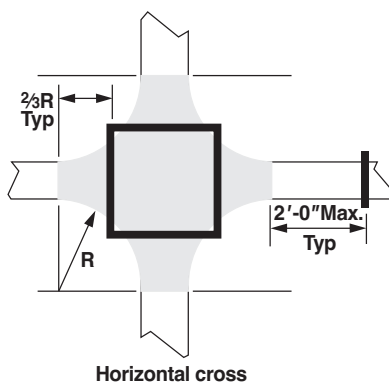
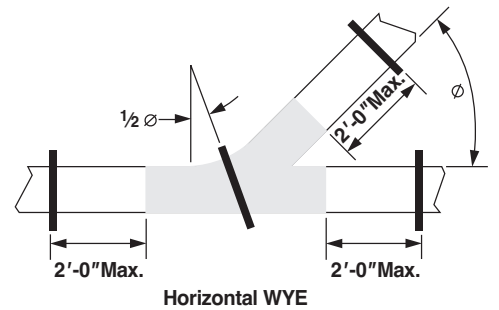
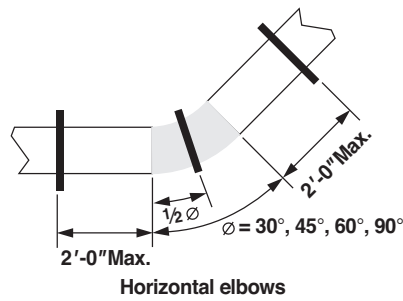
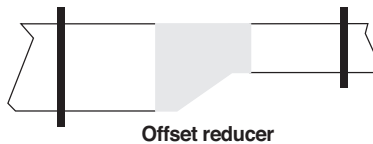
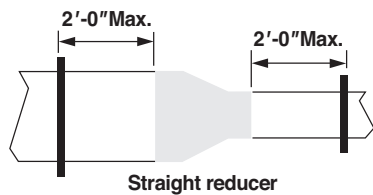

COPE-GLAS™ CABLE TRAY SYSTEM

STRAIGHT SECTIONS

PART NUMBERING SYSTEM

All cable tray straight sections are available in polyester or vinyl ester resin. Standard tray lengths are 10' and 20'. Special tray lengths are available upon request.

Cable tray sections, except for Low Profile Type LC, can be provided with fiberglass strut substituted as alternating rungs upon request at no additional cost. Solid bottom cable tray sections are available,

but require special quotation. All cable tray sections are supplied pre-drilled to accept splice plate fasteners.

Note: Connector plates and hardware are not included and must be ordered separately.

TYPE LC STRAIGHT SECTION - C PROFILE* [LC]

Low Profile Tray

NEMA Class 12A

(100 lbs./ft. Working Load - 10' Length)

(50 lbs./ft. Working Load - 12' Length)

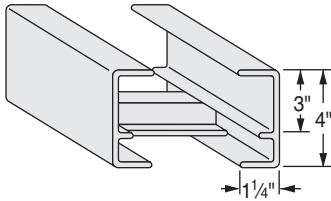

10 FOOT LENGTH PART NUMBERS (TYPE LC)

Rung Spacing	Section Width						
	06" (152mm)	09" (229mm)	12" (305mm)	18" (457mm)	24" (610mm)	30" (762mm)	36" (914mm)
06"	LC060610	LC090610	LC120610	LC180610	LC240610	LC300610	LC360610
09"	LC060910	LC090910	LC120910	LC180910	LC240910	LC300910	LC360910
12"	LC061210	LC091210	LC121210	LC181210	LC241210	LC301210	LC361210

12 FOOT LENGTH PART NUMBERS (TYPE LC)

Rung Spacing	Section Width						
	06" (152mm)	09" (229mm)	12" (305mm)	18" (457mm)	24" (610mm)	30" (762mm)	36" (914mm)
06"	LC060612	LC090612	LC120612	LC180612	LC240612	LC300612	LC360612
09"	LC060912	LC090912	LC120912	LC180912	LC240912	LC300912	CE360912
12"	LC061212	LC091212	LC121212	LC181212	LC241212	LC301212	LC361212

TYPE BE STRAIGHT SECTION - E PROFILE [BE]

NEMA Class 20C

(100 lbs./ft. Working Load - 20' Length)

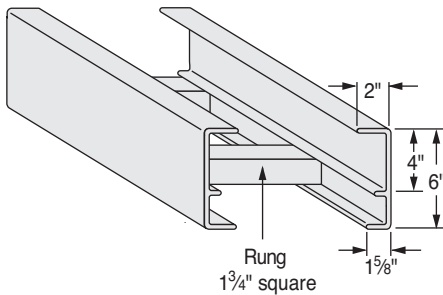

10 FOOT LENGTH PART NUMBERS (TYPE BE)

Rung Spacing	Section Width						
	06" (152mm)	09" (229mm)	12" (305mm)	18" (457mm)	24" (610mm)	30" (762mm)	36" (914mm)
06"	BE060610	BE090610	BE120610	BE180610	BE240610	BE300610	BE360610
09"	BE060910	BE090910	BE120910	BE180910	BE240910	BE300910	BE360910
12"	BE061210	BE091210	BE121210	BE181210	BE241210	BE301210	BE361210

20 FOOT LENGTH PART NUMBERS (TYPE BE)

Rung Spacing	Section Width						
	06" (152mm)	09" (229mm)	12" (305mm)	18" (457mm)	24" (610mm)	30" (762mm)	36" (914mm)
06"	BE060620	BE090620	BE120620	BE180620	BE240620	BE300620	BE360620
09"	BE060920	BE090920	BE120920	BE180920	BE240920	BE300920	CE360920
12"	BE061220	BE091220	BE121220	BE181220	BE241220	BE301220	BE361220

Ordering Information:

[S][W][R][L] [V]* [SR]*

Tray Style (LC, BE, CE, CZ, CZD) ———

Width (6", 9", 12", 18", 24", 30", 36") ———

Rung Spacing (6", 9", 12", 18") ———

Length (10', 20')

Suffix

SR=Strut as Alternating Rungs
MR=Marine Rungs
Vinyl Ester Resin

Example: CZ181220VSR
CZ Style Tray, 18" Wide, 12" Rung Spacing, 20' Long
Vinyl Ester Resin, with Alternating Strut Rungs.

* Add suffix "V" to specify vinyl ester resin, add "SR" to specify strut as alternating rungs, add "MR" for marine rungs
Note: See page 200 for cable tray straight section cover options and part numbers.

STRAIGHT SECTIONS

TYPE CE STRAIGHT SECTION - E PROFILE [CE]

NEMA Class 20C+
(133 lbs./ft. Working Load -
20' length)

See ordering information on previous page

* 2:1 Safety Factor

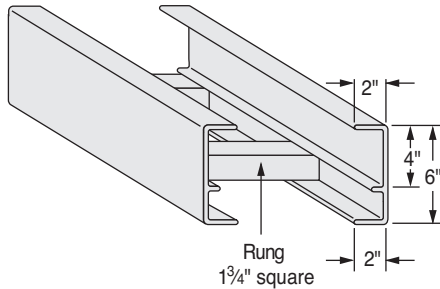

10 FOOT LENGTH PART NUMBERS (TYPE CZD)

Rung Spacing	Section Width						
	06" (152mm)	09" (229mm)	12" (305mm)	18" (457mm)	24" (610mm)	30" (762mm)	36" (914mm)
06"	CZD060610	CZD090610	CZD120610	CZD180610	CZD240610	CZD300610	CZD360610
09"	CZD060910	CZD090910	CZD120910	CZD180910	CZD240910	CZD300910	CZD360910
12"	CZD061210	CZD091210	CZD121210	CZD181210	CZD241210	CZD301210	CZD361210
18"	CZD061810	CZD091810	CZD121810	CZD181810	CZD241810	CZD301810	CZD361810

20 FOOT LENGTH PART NUMBERS (TYPE CZD)

Rung Spacing	Section Width						
	06" (152mm)	09" (229mm)	12" (305mm)	18" (457mm)	24" (610mm)	30" (762mm)	36" (914mm)
06"	CZD060620	CZD090620	CZD120620	CZD180620	CZD240620	CZD300620	CZD360620
09"	CZD060920	CZD090920	CZD120920	CZD180920	CZD240920	CZD300920	CZD360920
12"	CZD061220	CZD091220	CZD121220	CZD181220	CZD241220	CZD301220	CZD361220
18"	CZD061820	CZD091820	CZD121820	CZD181820	CZD241820	CZD301820	CZD361820

TYPE CZ STRAIGHT SECTION - Z PROFILE [CZ]

NEMA Class 20C+
(133 lbs./ft. Working Load -
20' length)

See ordering information on previous page

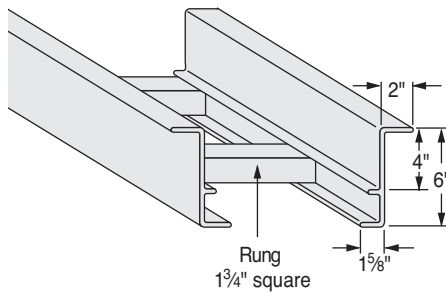

10 FOOT LENGTH PART NUMBERS (TYPE CE)

Rung Spacing	Section Width						
	06" (152mm)	09" (229mm)	12" (305mm)	18" (457mm)	24" (610mm)	30" (762mm)	36" (914mm)
06"	CE060610	CE090610	CE120610	CE180610	CE240610	CE300610	CE360610
09"	CE060910	CE090910	CE120910	CE180910	CE240910	CE300910	CE360910
12"	CE061210	CE091210	CE121210	CE181210	CE241210	CE301210	CE361210
18"	CE061810	CE091810	CE121810	CE181810	CE241810	CE301810	CE361810

20 FOOT LENGTH PART NUMBERS (TYPE CE)

Rung Spacing	Section Width						
	06" (152mm)	09" (229mm)	12" (305mm)	18" (457mm)	24" (610mm)	30" (762mm)	36" (914mm)
06"	CE060620	CE090620	CE120620	CE180620	CE240620	CE300620	CE360620
09"	CE060920	CE090920	CE120920	CE180920	CE240920	CE300920	CE360920
12"	CE061220	CE091220	CE121220	CE181220	CE241220	CE301220	CE361220
18"	CE061820	CE091820	CE121820	CE181820	CE241820	CE301820	CE361820

TYPE CZD STRAIGHT SECTION - DEEP Z PROFILE [CZD]

NEMA Class 20C+
(133 lbs./ft. Working Load -
20' length)

See ordering information on previous page

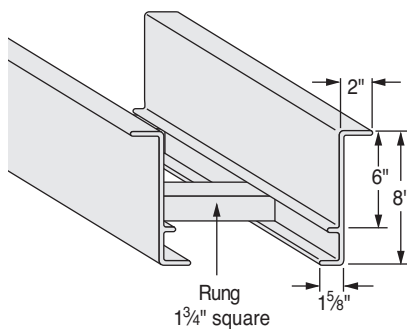

10 FOOT LENGTH PART NUMBERS (TYPE CZ)

Rung Spacing	Section Width						
	06" (152mm)	09" (229mm)	12" (305mm)	18" (457mm)	24" (610mm)	30" (762mm)	36" (914mm)
06"	CZ060610	CZ090610	CZ120610	CZ180610	CZ240610	CZ300610	CZ360610
09"	CZ060910	CZ090910	CZ120910	CZ180910	CZ240910	CZ300910	CZ360910
12"	CZ061210	CZ091210	CZ121210	CZ181210	CZ241210	CZ301210	CZ361210
18"	CZ061810	CZ091810	CZ121810	CZ181810	CZ241810	CZ301810	CZ361810

20 FOOT LENGTH PART NUMBERS (TYPE CZ)

Rung Spacing	Section Width						
	06" (152mm)	09" (229mm)	12" (305mm)	18" (457mm)	24" (610mm)	30" (762mm)	36" (914mm)
06"	CZ060620	CZ090620	CZ120620	CZ180620	CZ240620	CZ300620	CZ360620
09"	CZ060920	CZ090920	CZ120920	CZ180920	CZ240920	CZ300920	CZ360920
12"	CZ061220	CZ091220	CZ121220	CZ181220	CZ241220	CZ301220	CZ361220
18"	CZ061820	CZ091820	CZ121820	CZ181820	CZ241820	CZ301820	CZ361820

COVERS

COPE-GLAS CABLE TRAY COVERS

Covers are used where cable protection is necessary or desired. Two COPE-GLAS cover designs, flat and peaked, are offered. The flat cover suits most applications and is more widely used; however, where the accumulation of snow or other particulate is likely, the peak cover will help shed excessive loads on the cable tray system. Flat covers are available in polyester or vinyl ester resin and are offered in ten foot lengths. To specify vinyl ester resin, add the suffix "V" to the part number. Peaked covers are made from polypropylene and are supplied in black. Peaked covers are not available for COPE-GLAS fittings.

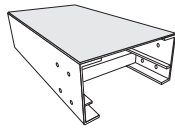

Flat Cover

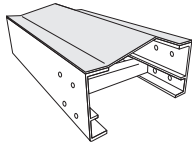

Peaked Cover
Note: 5' Lengths only

Installation procedures for covers are located in the Installation Procedures Section of this catalog.

FLAT COVER FOR "Z" SHAPED PROFILE SIDERAIL				FLAT COVER FOR "E" SHAPED PROFILE SIDERAILS			
Tray Width	Polyester Resin	Vinyl Ester Resin	Wt./ Ft.	Tray Width	Polyester Resin	Vinyl Ester Resin	Wt./ Ft.
06"	CTC06	CTC06V	0.8	06"	CTCE06	CTCE06V	0.7
09"	CTC09	CTC09V	1	09"	CTCE09	CTCE09V	0.9
12"	CTC12	CTC12V	1.2	12"	CTCE12	CTCE12V	1.1
18"	CTC18	CTC18V	1.6	18"	CTCE18	CTCE18V	1.5
24"	CTC24	CTC24V	2.1	24"	CTCE24	CTCE24V	2
30"	CTC30	CTC30V	2.6	30"	CTCE30	CTCE30V	2.5
36"	CTC36	CTG36V	3	36"	CTCE36	CTCE36V	2.9

PEAKED COVER FOR "Z" SHAPED PROFILE SIDERAIL			PEAKED COVER FOR "E" SHAPED PROFILE SIDERAILS		
Tray Width	PVC	Wt./Ft.	Tray Width	PVC	Wt./Ft.
06"	PTK06	0.9	06"	PTKE06	1
09"	PTK09	1.1	09"	PTKE09	1.2
12"	PTK12	1.3	12"	PTKE12	1.7
18"	PTK18	1.8	18"	PTKE18	1.8
24"	PTK24	2.3	24"	PTKE24	2.2
30"	PTK30	2.9	30"	PTKE30	2.8
36"	PTK36	3.3	36"	PTKE36	3.3

FITTINGS

All types and widths of tray are available as fittings with the COPE-GLAS Cable Tray System. All fittings are pre-drilled at the factory to accept splice plate fasteners. Rung spacing specified in the tray straight sections does not necessarily apply to fittings.

Molded Fittings

Type LC Low Profile and Type "BE" & "CE" tray fitting side rails are resin transfer molded with smooth radius corners. Smooth radius fittings are compact and the curved rail shape is an aid for cable pulling. The following fittings are available in smooth radius:

Type LC Smooth Radius Fittings

- 90° Inside Vertical Assemblies
- 90° Outside Vertical Assemblies
- 90° Horizontal Bend Assembly, All 12" width, 12" radius
- Vertical Tee Assemblies
- Horizontal Tee Assemblies
- Horizontal Cross Assemblies

Type BE and CE Smooth Radius Fittings

- 90° Inside Vertical Assemblies, 12" & 24" radius
- 90° Outside Vertical Assemblies, 12" & 24" radius
- 90° Horizontal Bend Assemblies 24" & 36" width, 12" radius
- 06", 09", 12", 18", & 24" width, 24" radius
- Vertical Tee Assemblies 12" & 24" radius
- Horizontal Tee Assemblies 12" & 24" radius
- Horizontal Cross Assemblies 12" & 24" radius

Type CZ, 24" Radius Molded Fittings

- Type CZ tray 24" radius fittings are compression molded with a NEMA Load Class C rating. All 24" radius fittings will be molded unless otherwise specified. Molded fittings are stocked for quick shipment. They are also dimensionally consistent to assure a precise fit at the job site.
- 90° Inside & Outside Vertical
- 90° Horizontal
- 90° Horizontal Tee
- Horizontal Cross

Mitered Fittings

All 12" and 36" radius assemblies and reducing assemblies for CZ and CZD trays are fabricated from cut and mitered side rail sections. All BE and CE tray, 36" radius fittings and horizontal bends (with the exception of those listed in the molded fittings text) will also be mitered.

Custom Fittings

Factory engineering support will help with your special requirements; 30° and 60° bends along with other special fittings are available upon request.

Cable Tray Fitting Part Numbering System

With each fitting drawing, there is an example of how to create the correct part number for the fittings and its cover. Alternating strut and rungs can be provided by using the suffix "SR".

90° VERTICAL INSIDE BENDS [V90I]

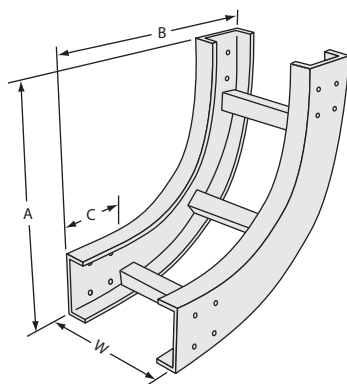
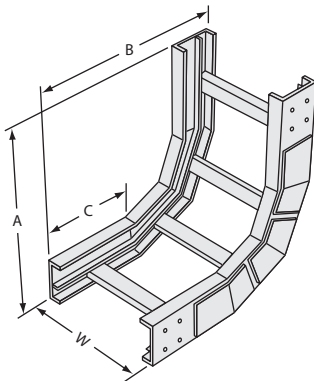

90° VERTICAL OUTSIDE BENDS - MITERED

Tray Style	Radius	A or B	C (Straight)	Close-Coupled Inside & Outside Fittings	
				Rise	Length
CZ	12" (305mm)	30" (762mm)	13 ⁵ / ₁₆ " (346mm)	52 ¹ / ₁₆ " (1322mm)	52" (1321mm)
CZD	12" (305mm)	32" (813mm)	13 ⁵ / ₁₆ " (346mm)	52 ¹ / ₁₆ " (1322mm)	52" (1321mm)
CZ	24" (610mm)	27 ¹⁵ / ₁₆ " (710mm)	4 ⁵ / ₁₆ " (110mm)	49 ¹³ / ₁₆ " (1265mm)	49 ³ / ₄ " (1264mm)
CZD	24" (610mm)	44" (1118mm)	13 ⁵ / ₁₆ " (346mm)	76 ¹ / ₁₆ " (1932mm)	76" (1930mm)
CZ, CZD, BE, CE	36" (914mm)	54" (1372mm)*	13 ⁵ / ₁₆ " (346mm)	100 ¹ / ₁₆ " (2542mm)	100" (2540mm)

90° VERTICAL OUTSIDE BENDS - SMOOTH RADIUS

Tray Style	Radius	A or B	C (Straight)	Close-Coupled Inside & Outside Fittings	
				Rise	Length
LC	12" (305mm)	20" (508mm)	5" (127mm)	36 ¹ / ₁₆ " (916mm)	36" (914mm)
LC	24" (610mm)	32" (813mm)	5" (127mm)	60 ¹ / ₁₆ " (1526mm)	60" (1524mm)
BE, CE	12" (305mm)	21 ¹⁵ / ₁₆ " (557mm)	6" (152mm)	37 ¹⁵ / ₁₆ " (964mm)	37 ⁷ / ₈ " (914mm)
BE, CE	24" (610mm)	33 ¹⁵ / ₁₆ " (862mm)	6" (152mm)	61 ¹⁵ / ₁₆ " (1574mm)	61 ⁷ / ₈ " (1524mm)

90° VERTICAL OUTSIDE BENDS [V90O]

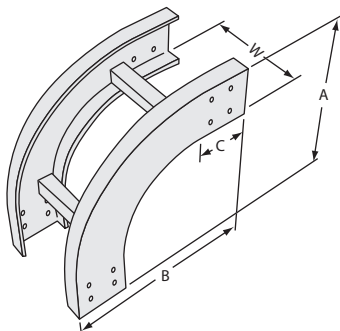
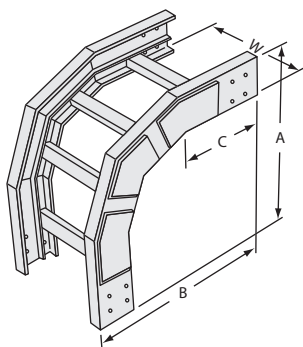

90° VERTICAL INSIDE BENDS - SMOOTH RADIUS

Tray Style	Radius	A or B	C (Straight)	Close-Coupled Inside & Outside Fittings	
				Rise	Length
LC	12" (305mm)	20" (508mm)	5" (127mm)	36 ¹ / ₁₆ " (916mm)	36" (914mm)
LC	24" (610mm)	32" (813mm)	5" (127mm)	60 ¹ / ₁₆ " (1526mm)	60" (1524mm)
BE, CE	12" (305mm)	21 ¹⁵ / ₁₆ " (557mm)	6" (152mm)	37 ¹⁵ / ₁₆ " (964mm)	37 ⁷ / ₈ " (914mm)
BE, CE	24" (610mm)	33 ¹⁵ / ₁₆ " (862mm)	6" (152 mm)	61 ¹⁵ / ₁₆ " (1574mm)	61 ⁷ / ₈ " (1524mm)

90° VERTICAL INSIDE BENDS - MITERED

Tray Style	Radius	A or B	C (Straight)	Close-Coupled Inside & Outside Fittings	
				Rise	Length
CZ	12" (305mm)	28" (711mm)	13 ¹ / ₁₆ " (335mm)	52 ¹ / ₁₆ " (1322mm)	52" (1321mm)
CZD	12" (305mm)	28" (711mm)	12 ¹³ / ₁₆ " (325mm)	52 ¹ / ₁₆ " (1322mm)	52" (1321mm)
CZ	24" (610mm)	27 ¹⁵ / ₁₆ " (710mm)	4 ⁵ / ₁₆ " (110mm)	49 ¹³ / ₁₆ " (1265mm)	49 ³ / ₄ " (1264mm)
CZD	24" (914mm)	40" (1016mm)	12 ¹³ / ₁₆ " (325mm)	76 ¹ / ₁₆ " (1932mm)	76" (1930mm)
CZ, BE, CE	36" (914mm)	52" (1321mm)	13 ³ / ₁₆ " (335mm)	100 ¹ / ₁₆ " (2542mm)	100" (2540mm)
CZD	36" (914mm)	52" (1321mm)	12 ¹³ / ₁₆ " (325mm)	100 ¹ / ₁₆ " (2542mm)	100" (2540mm)

FITTINGS

45° VERTICAL INSIDE BENDS [V45I]

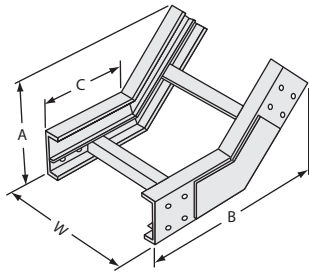

45° VERTICAL INSIDE BENDS [V45I]

Tray Style	A	B	C (Straight)	Close-Coupled Inside & Outside Fittings	
				Rise	Length
LC	11¼" (286mm)	20 ¹⁵ / ₁₆ " (517mm)	11 ¹⁵ / ₁₆ " (304mm)	15¾" (399mm)	37 ⁷ / ₈ " (963mm)
CZ, BE, CE	14½" (368mm)	24¾" (629mm)	12" (305mm)	18¾" (476mm)	45¼" (1149mm)
CZD	15 ¹⁵ / ₁₆ " (405mm)	24¾" (629mm)	11 ¹⁵ / ₁₆ " (284mm)	18¾" (476mm)	45¼" (1149mm)

45° VERTICAL OUTSIDE BENDS [V45O]

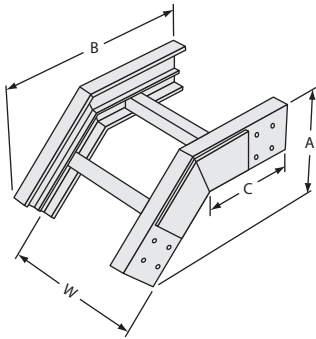

45° VERTICAL OUTSIDE BENDS [V45O]

Tray Style	A	B	C (Straight)	Close-Coupled Inside & Outside Fittings	
				Rise	Length
LC	11¼" (286mm)	20 ¹⁵ / ₁₆ " (517mm)	11 ¹⁵ / ₁₆ " (304mm)	15¾" (399mm)	37 ⁷ / ₈ " (963mm)
CZ, BE, CE, CZD	14½" (368mm)*	24¾" (629mm)	12" (305mm)	18¾" (476mm)	45¼" (1149mm)
CZD	16½" (419mm)	26 ¹ / ₈ " (664mm)	12" (305mm)	18¾" (476mm)	45¼" (1149mm)

Vertical inside/Outside Bends - Part Numbering System

The following information will help you order vertical bends for your application. Special fittings are available upon request. Strut as rungs can be provided every other rung at no additional cost. Solid bottom fittings are available through special quotation. Smooth radius vertical bends are available for Type LC, BE, and CE cable trays in 12" and 24" radius. All Type CZ and CZD fittings will be mitered as will BE and CE 36" radius fittings.

Ordering Information Fittings:

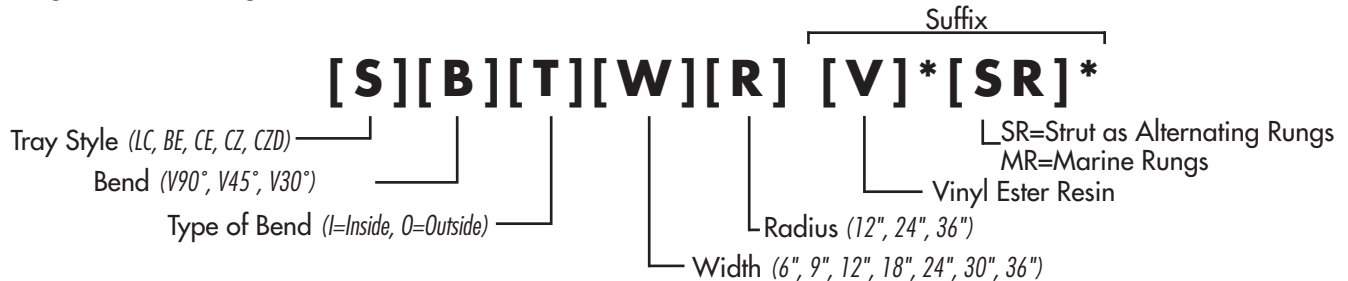

Example: CZV90I2412VSR

CZ Style Tray, 90° Inside Vertical Bend, 24" Wide, 12" Radius, Vinyl Ester Resin, With Alternating Strut Rungs.

* Add suffix "V" to specify vinyl ester resin, add "SR" to specify strut as alternating rungs, add "MR" to specify Marine Rungs

Ordering Information Covers:



Example: ZV90I2412V

Cover Style Z, 90° Inside Vertical Bend, 24" Wide, 12" Radius, Vinyl Ester Resin.

* Add suffix "V" to specify vinyl ester resin

0° THRU 90° VERTICAL ADJUSTABLE BENDS [VAB]

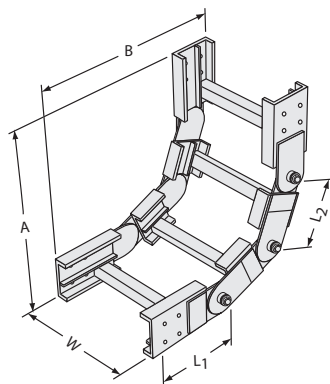
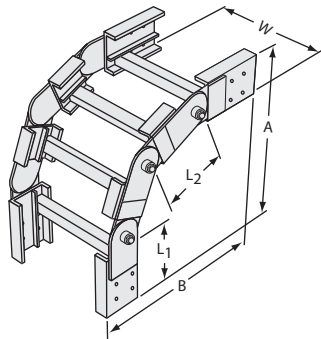

Tray Style	Radius	A or B (@90°)	Leg L1	Leg L2
LC	12" (305mm)	26 ¹ / ₈ " (664mm)	11 ¹ / ₄ " (286mm)	9 ⁷ / ₈ " (251mm)
LC	24" (610mm)	38 ¹ / ₁₆ " (967mm)	11 ¹ / ₄ " (286mm)	19" (483mm)
CZ, CZD, BE, CE	12" (305mm)	28" (711mm)	12 ¹ / ₈ " (308mm)	9 ⁷ / ₈ " (251mm)
CZ, CZD, BE, CE	24" (610mm)	39 ¹⁵ / ₁₆ " (1014mm)	12 ¹ / ₈ " (308mm)	19" (483mm)
CZ, CZD, BE, CE	36" (914mm)	51 ¹⁵ / ₁₆ " (1319mm)	12 ¹ / ₈ " (308mm)	28 ³ / ₁₆ " (716mm)

Vertical Adjustable Bends - Part Number System

This versatile fitting is fully adjustable from 0° to 90° and can accommodate either an inside or outside bend. Strut rungs can be provided every other rung at no additional cost.

Ordering Information Fittings:



Example: CZVAB2412VSR
 CZ Style Tray, Vertical Adjustable Bend, 24" Wide, 12" Radius, Vinyl Ester Resin, with Alternating Strut Rungs.

* Add suffix "V" to specify vinyl ester resin, add "SR" to specify strut as alternating rungs, add "MR" to specify Marine rungs

Ordering Information Covers:



Example: ZVAB2412V
 Z Style Cover, Vertical Adjustable Bend, 24" Wide, 12" Radius, Vinyl Ester Resin.

* Add suffix "V" to specify vinyl ester resin

FITTINGS

VERTICAL TEES [VT]

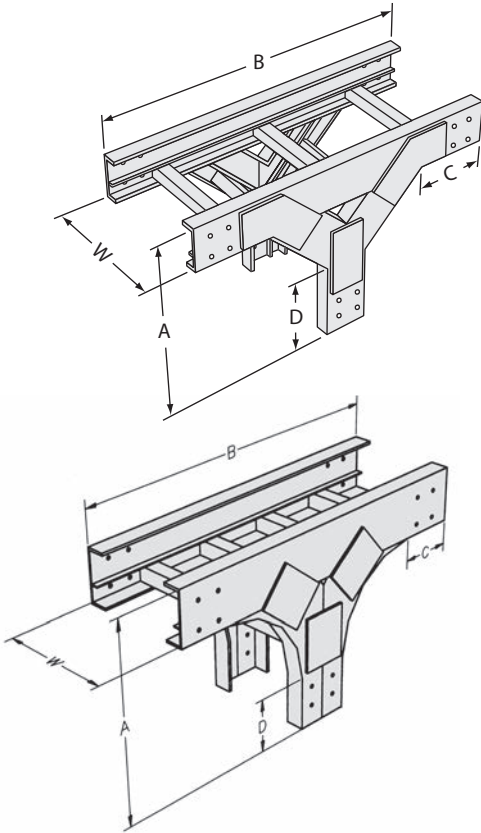

VERTICAL TEES-MITERED

Tray Style	Radius	A	B	C (Straight)	D (Straight)
CZ	12" (305mm)	25 ⁵ / ₈ " (657mm)	44" (1118mm)	10 ¹ / ₈ " (257mm)	11" (279mm)
CZD	12" (305mm)	29 ¹ / ₄ " (756mm)	46" (1169mm)	8 ¹ / ₄ " (210mm)	11" (279mm)
CZ	24" (610mm)	35" (889mm)	64" (1626mm)	14 ¹ / ₂ " (368mm)	14 ¹ / ₂ " (368mm)
CZD	24" (610mm)	37" (940mm)	66" (1676mm)	14 ¹ / ₂ " (368mm)	14 ¹ / ₂ " (368mm)
CZ, BE, CE	36" (914mm)	47" (1194mm)	88" (2235mm)	18 ¹ / ₁₆ " (478mm)	18 ¹ / ₁₆ " (478mm)
CZD	36" (914mm)	49" (1245mm)	90" (2286mm)	18 ¹ / ₁₆ " (478mm)	18 ¹ / ₁₆ " (478mm)

VERTICAL TEES-SMOOTH RADIUS

Tray Style	Radius	A	B	C (Straight)
LC	12" (305mm)	20" (508mm)	36" (914mm)	5" (127mm)
LC	24" (610mm)	32" (813mm)	60" (1524mm)	5" (127mm)
BE, CE	12" (305mm)	21 ¹⁵ / ₁₆ " (557mm)	37 ⁷ / ₈ " (962mm)	6" (152mm)
BE, CE	24" (610mm)	33 ¹⁵ / ₁₆ " (862mm)	61 ⁷ / ₈ " (1572mm)	6" (152mm)

Vertical Tee - Part Number System

This assembly can be provided with strut rungs at no additional cost. Solid bottom fittings are available through special quotation. Smooth radius vertical tees are available for type LC, BE, and CE cable trays in 12" and 24" radius. All type CZ and CZD fittings will be mitered as will type BE and CE 36" radius fittings.

Ordering Information Fittings:



Example: LCVT1224SR
LC Style Tray, Vertical Tee, 12" Wide, 24" Radius, Polyester Resin, with Alternating Strut Rungs.

* Add suffix "V" to specify vinyl ester resin, add "SR" to specify strut as alternating rungs, add "MR" to specify Marine rungs

Ordering Information Covers:



Example: ZVT1224
Z Style Cover, Vertical Tee, 12" Wide, 24" Radius, Polyester Resin.

* Add suffix "V" to specify vinyl ester resin

90° HORIZONTAL BENDS [90H]

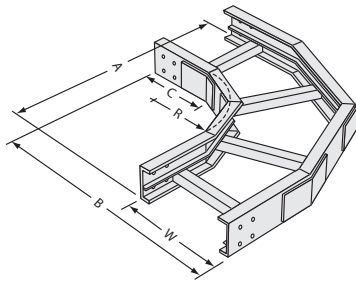

90° HORIZONTAL BENDS-MITERED

Tray Style	Radius	A or B (W Tray Width)	C (Straight)	Close-Coupled 90° Fittings	
				Offset	Length
LC	12" (305mm)	23 ³ / ₈ " (594mm)+W	11 ¹ / ₄ " (286mm)	46 ⁷ / ₁₆ " (1183mm)+W	46 ¹ / ₂ " (1181 mm)+W
LC	24" (610mm)	35 ³ / ₈ " (899mm)+W	11 ¹ / ₄ " (286mm)	70 ⁷ / ₈ " (1794mm)+W	70 ⁹ / ₁₆ " (1772mm)+W
CZ, CZD, BE, CE	12" (305mm)	25" (635mm)+W*	12 ¹⁵ / ₁₆ " (329mm)**	50 ¹ / ₁₆ " (1272mm)+W	50" (1270mm)+W
CZ	24" (610mm)	36 ³ / ₄ " (933mm)+W	16 ⁷ / ₈ " (429mm)	70 ¹ / ₁₆ " (1780mm)+W	70" (1778mm)+W
CZD, BE, CE	24" (610mm)	37" (940mm)+W*	12 ¹⁵ / ₁₆ " (329mm)**	74 ¹ / ₁₆ " (1881mm)+W	74" (1880mm)+W
CZ, CZD, BE, CE	36" (914mm)	49" (1245mm)+W*	12 ¹⁵ / ₁₆ " (329mm)**	98 ¹ / ₁₆ " (2491mm)+W	98" (2489mm)+W

*For "Z" style siderail add 2" (51 mm) to accommodate the upper flange

**For "Z" style siderail use 12⁵/₁₆" (321 mm)

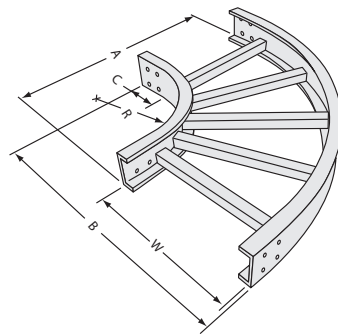

90° HORIZONTAL BENDS-SMOOTH RADIUS

Tray Style	Width	Radius	A or B (W Tray Width)	C (Straight)	Close-Coupled 90° Fittings	
					Offset	Length
LC	12" (305mm)	12" (305mm)	17 ¹ / ₈ " (435mm)+W	5 ¹⁵ / ₁₆ " (127mm)	34 ¹ / ₁₆ " (865mm)+W	34" (864mm)+W
BE, CE	24" (610mm)	12" (305mm)	18 ¹ / ₄ " (464mm)+W	6" (152mm)	60 ¹ / ₁₆ " (1526mm)+W	60" (1524mm)+W
BE, CE	36" (914mm)	12" (305mm)	18 ¹ / ₄ " (464mm)+W	6" (152mm)	60 ¹ / ₁₆ " (1526mm)+W	60" (1524mm)+W
BE, CE	6" (152mm)	24" (610mm)	30 ³ / ₄ " (768mm)+W	6" (152mm)	72 ¹ / ₁₆ " (1830mm)+W	72" (1829mm)+W
BE, CE	9" (229mm)	24" (610mm)	30 ³ / ₄ " (768mm)+W	6" (152mm)	72 ¹ / ₁₆ " (1830mm)+W	72" (1829mm)+W
BE, CE	12" (305mm)	24" (610mm)	30 ³ / ₄ " (768mm)+W	6" (152mm)	72 ¹ / ₁₆ " (1830mm)+W	72" (1829mm)+W
BE, CE	18" (457mm)	24" (610mm)	30 ³ / ₄ " (768mm)+W	6" (152mm)	72 ¹ / ₁₆ " (1830mm)+W	72" (1829mm)+W
BE, CE	24" (610mm)	24" (610mm)	30 ³ / ₄ " (768mm)+W	6" (152mm)	72 ¹ / ₁₆ " (1830mm)+W	72" (1829mm)+W

45° HORIZONTAL BENDS [45H]

45° HORIZONTAL BENDS [45H]

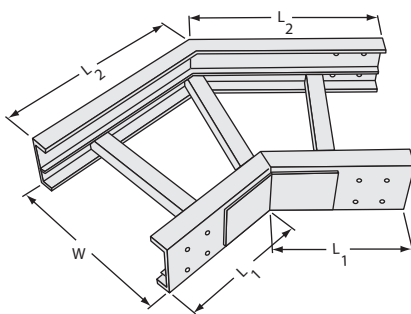

Tray Style	Tray Widths	L1	L2	Close-Coupled 45° Fittings	
				Offset	Length
LC	6" (152mm)	10 ⁵ / ₈ " (270mm)	12 ¹ / ₁₆ " (323mm)	16 ³ / ₁₆ " (411mm)	39" (991mm)
LC	9" (229mm)	10 ⁵ / ₈ " (270mm)	13 ¹³ / ₁₆ " (354mm)	17 ¹ / ₁₆ " (434mm)	41 ¹ / ₈ " (1045mm)
LC	12" (305mm)	10 ⁵ / ₈ " (270mm)	15 ³ / ₁₆ " (386mm)	17 ¹³ / ₁₆ " (456mm)	43 ¹ / ₄ " (1099mm)
LC	18" (457mm)	10 ⁵ / ₈ " (270mm)	17 ¹ / ₁₆ " (449mm)	19 ¹ / ₁₆ " (500mm)	47 ¹ / ₂ " (1207mm)
LC	24" (610mm)	10 ⁵ / ₈ " (270mm)	20 ³ / ₁₆ " (512mm)	21 ¹ / ₁₆ " (545mm)	51 ¹ / ₄ " (1314mm)
LC	30" (762mm)	10 ⁵ / ₈ " (270mm)	22 ³ / ₈ " (575mm)	23 ³ / ₄ " (591mm)	56" (1422mm)
LC	36" (914mm)	10 ⁵ / ₈ " (270mm)	25 ¹ / ₈ " (638mm)	25" (635mm)	60 ³ / ₄ " (1530mm)
CZ, BE, CE, CZD	6" (152mm)	13" (330mm)	15 ¹ / ₂ " (394mm)	20 ¹ / ₁₆ " (513mm)	48 ¹ / ₁₆ " (1237mm)
CZ, BE, CE, CZD	9" (229mm)	13" (330mm)	16 ³ / ₄ " (425mm)	21 ¹ / ₁₆ " (535mm)	50 ³ / ₁₆ " (1291mm)
CZ, BE, CE, CZD	12" (305mm)	13" (330mm)	18" (457mm)	21 ¹⁵ / ₁₆ " (557mm)	52 ¹⁵ / ₁₆ " (1345mm)
CZ, BE, CE, CZD	18" (457mm)	13" (330mm)	20 ¹ / ₁₆ " (519mm)	23 ¹ / ₁₆ " (602mm)	57 ¹ / ₁₆ " (1453mm)
CZ, BE, CE, CZD	24" (610mm)	13" (330mm)	22 ¹⁵ / ₁₆ " (583mm)	25 ¹ / ₁₆ " (646mm)	61 ³ / ₈ " (1559mm)
CZ, BE, CE, CZD	30" (762mm)	13(330mm)	25 ¹ / ₁₆ " (646mm)	27 ¹ / ₁₆ " (691mm)	65 ³ / ₈ " (1667mm)
CZ, BE, CE, CZD	36" (914mm)	13(330mm)	27 ¹⁵ / ₁₆ " (710mm)	29" (737mm)	69 ¹ / ₈ " (1775mm)

FITTINGS

HORIZONTAL BENDS - PART NUMBER SYSTEM

The following information will help you order horizontal bends for your application. Special fittings are available upon request. Strut rungs can be provided every other rung at no additional cost. Solid bottom fittings are available through special quotation. Smooth radius bends are available in the following tray sizes:

- LC** 90° Horizontal Bend, 12" width, 12" radius
- BE & CE** 90° Horizontal Bend, 24" and 36" width, 12" radius
- BE & CE** 90° Horizontal Bend, 6", 9", 12", 18", 24", and 30" width, 24" radius

Ordering Information Fittings:

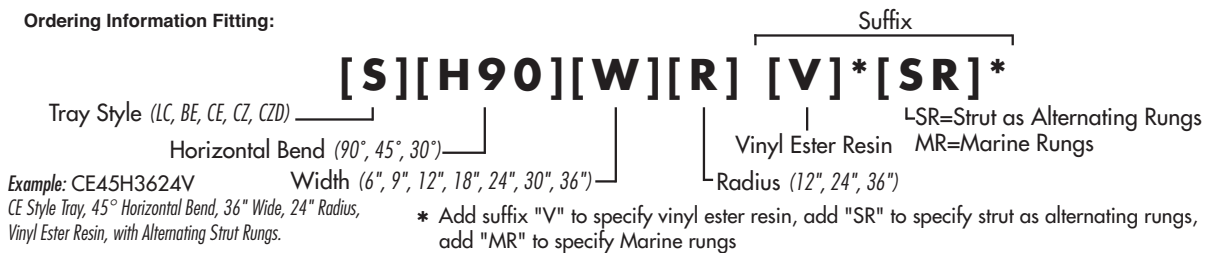

Ordering Information Covers:

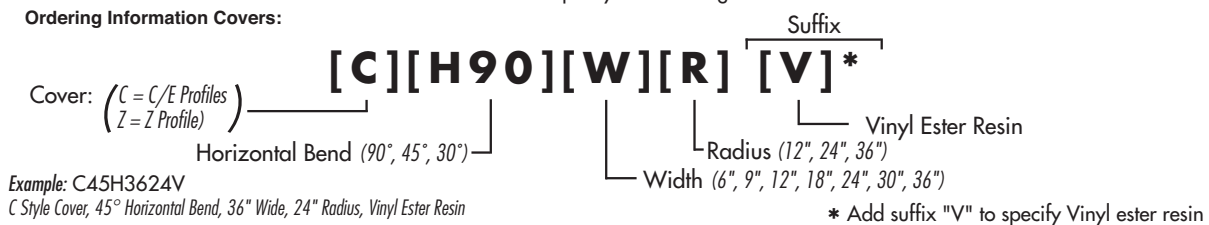

HORIZONTAL ADJUSTABLE BENDS [HAB]

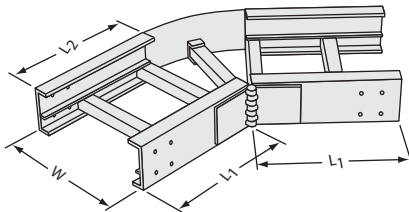

HORIZONTAL ADJUSTABLE BENDS [HAB]

Tray style	Angle Adjustment Range	Leg L1	Leg L2
LC	25°-65°	16 ¹ / ₁₆ " (408mm)	16 ¹ / ₁₆ " (408mm)
LC	60°-100°	16 ¹ / ₁₆ " (408mm)	16 ¹ / ₁₆ " (408mm)
CZ, CZD, BE, CE	25°-65°	18" (457mm)	18" (457mm)
CZ, CZD, BE, CE	60°-100°	18" (457mm)	18" (457mm)

Horizontal Adjustable Bends Part Number System

This versatile fitting is offered in two designs to accommodate a full range of adjustment.

Style "A" design is adjustable from 25° to 65°.

Style "B" design is adjustable from 60° to 100°

The range of adjustment must be specified when ordering this fitting. Strut rungs can be provided every other rung at no additional cost. Horizontal adjustable bends are available in all tray widths except 6".

Ordering Information Fittings:

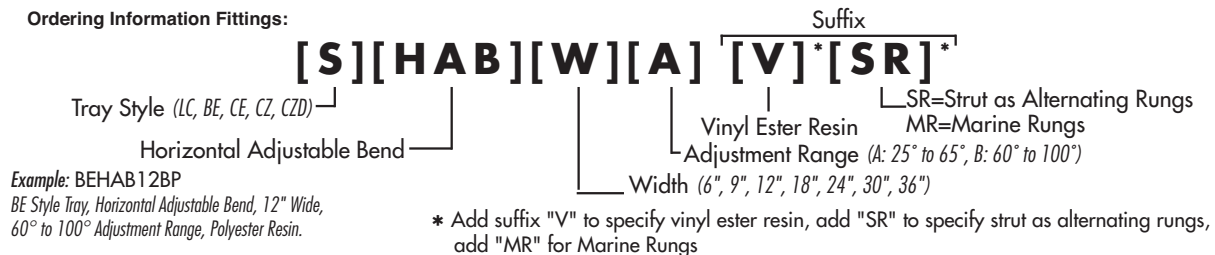

Ordering Information Covers:



HORIZONTAL TEES [T]

HORIZONTAL TEES-MITERED

Tray Style	Radius	A (W=Tray Width)	B	C (Straight)
CZ, CZD	12" (305mm)	27" (686mm)+W1 or W2	50" (1270mm)+W3	12 ³ / ₁₆ " (310mm)
CZ	24" (610mm)	26" (660mm)+W1 or W2	48" (1219mm)+W3	6 ¹ / ₈ " (156mm)
CZD	24" (610mm)	39" (991 mm)+W1 or W2	74" (1880mm)+W3	12 ³ / ₁₆ " (310mm)
CZ, CZD, BE, CE	36" (914mm)	49" (1245mm)+W1* or W2*	98" (2489mm)+W3	12 ⁵ / ₁₆ " (329mm)*

t For Reducing Tees use wider of W1 or W2
 *For "Z" style siderail add 2" (51 mm) to accommodate the upper flange
 *For "Z" style siderail use 12⁵/₁₆" (310mm)

HORIZONTAL TEES-SMOOTH RADIUS

Tray Style	Radius	At (W=Tray Width)	B	C (Straight)
LC	12" (305mm)	17 ¹ / ₈ " (435mm)+W1 or W2	34" (864mm)+W3	5" (127mm)
LC	24" (610mm)	41 ¹ / ₈ " (1095mm)+W1 or W2	58" (1473mm)+W3	5" (127mm)
BE, CE	12" (305mm)	18 ¹ / ₄ " (464mm)+W1 or W2	36" (914mm)+W3	6" (152mm)
BE, CE	24" (610mm)	30 ³ / ₄ " (786mm)+W1 or W2	60" (1524mm)+W3	6" (152mm)

For Reducing Tees use wider of W1 or W2

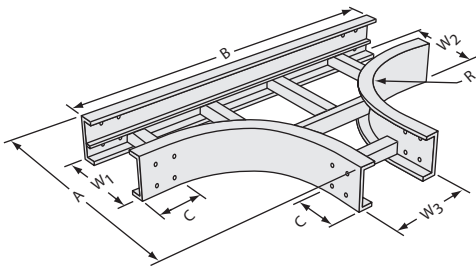
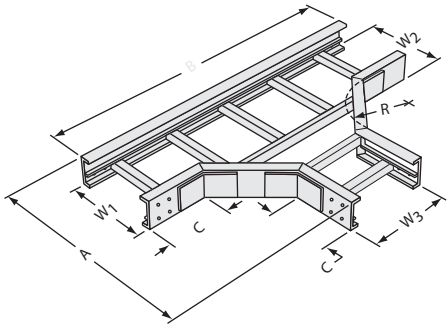

Horizontal Tees - Part Number System

This assembly is commonly provided with equal width legs for standard tees but can also be provided with reduced width legs. Strut as rungs can be provided every other rung at no additional cost. Solid bottom fittings and reducing tees are available through special quotation. Smooth radius horizontal tees are available for type LC, BE and CE cable trays in 12" and 24" radius. All type CZ, and CZD fittings will be mitered as will type BE and CE 36" radius fittings.

Ordering Information Fittings:

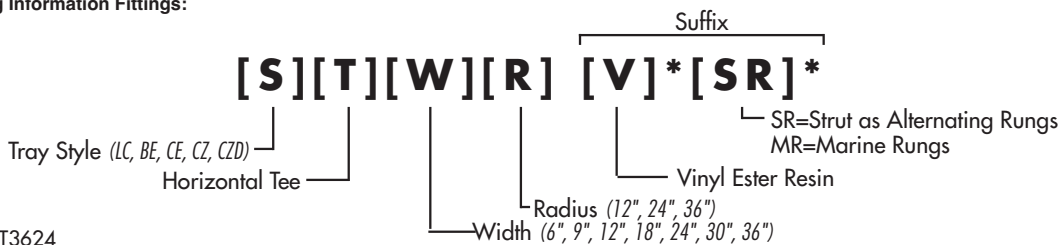

Example: CZT3624
 CZ Style Tray, Horizontal Tee, 36" Wide, 24" Radius, Polyester Resin.

* Add suffix "V" to specify vinyl ester resin, add "SR" to specify strut as alternating rungs, add "MR" to specify Marine rungs

Ordering Information Covers:

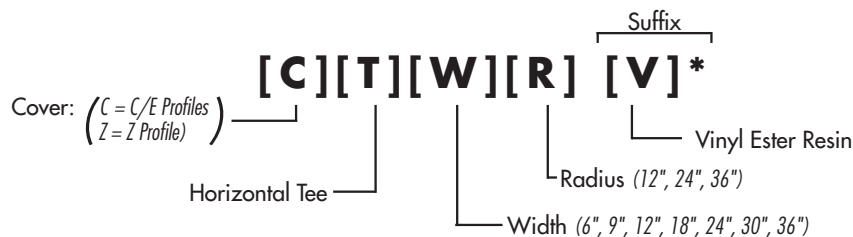

Example: ZT3624
 Z Style Cover, Horizontal Tee, 36" Wide, 24" Radius, Polyester Resin

* Add suffix "V" to specify Vinyl ester resin

HORIZONTAL CROSSOVERS [X]

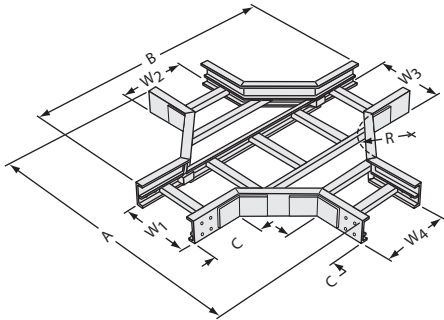

HORIZONTAL CROSSOVERS-MITERED

Tray Style	Radius	A (W=Tray Width)	B	C (Straight)
CZ, CZD	12" (305mm)	50" (1270mm)+W1 or W3	50" (1270mm)+W2 or W4	12 ³ / ₁₆ " (310mm)
CZ	24" (610mm)	48" (1219mm)+W1 or W3	48" (1219mm)+W2 or W4	6 ¹ / ₈ " (156mm)
CZD	24" (610mm)	74" (1880mm)+W1 or W3	74" (1880mm)+W2 or W4	12 ³ / ₁₆ " (310mm)
CZ, CZD, BE, CE	36" (914mm)	98" (2489mm)+W1 or W3	98" (2489mm)+W2 or W4	12 ⁵ / ₁₆ " (329mm)*

For Reducing Crossovers use wider of W1 or W3
 For Reducing Crossovers use wider of W2 or W4
 *For "Z" style siderail use 12³/₁₆" (310mm)

HORIZONTAL CROSSOVERS-SMOOTH RADIUS

Tray Style	Radius	A (W=Tray Width)	B	C (Straight)
LC	12" (305mm)	34" (864mm)+W1 or W3	34" (864mm)+W1 or W3	5" (127mm)
LC	24" (610mm)	58" (1473mm)+W1 or W3	58" (1473mm)+W1 or W3	5" (127mm)
BE, CE	12" (305mm)	36" (914mm)+W1 or W3	36" (914mm)+W1 or W3	6" (152mm)
BE, CE	24" (610mm)	60" (1524mm)+W1 or W3	60" (1524mm)+W1 or W3	6" (152mm)

For Reducing Crossovers use wider of W1 or W3
 For Reducing Crossovers use wider of W2 or W4

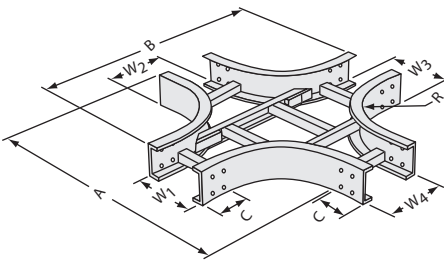

Horizontal Cross - Part Number System

This assembly is commonly provided with equal width legs for standard crosses but can also be provided with reduced width legs. Strut as rungs can be provided every other rung at no additional cost. Solid bottom fittings and reducing tees are available through special quotation. Smooth radius horizontal tees are available for type LC, BE, and CE cable trays in 12" and 24" radius. All type CZ, and CZD fittings will be mitered as will type BE and CE 36" radius fittings.

Ordering Information Fittings:

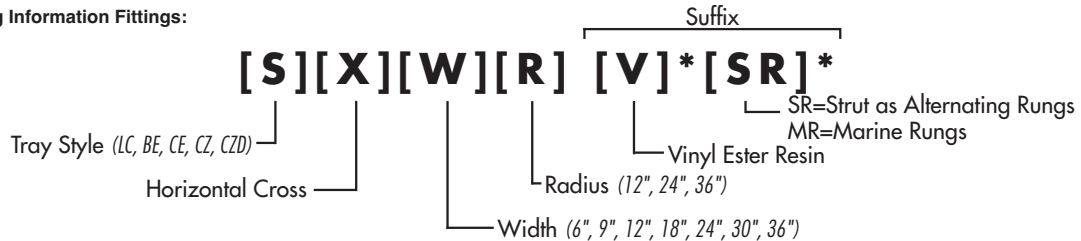

Example: BEX1812
 BE Style Tray, Horizontal Cross, 18" Wide,
 12" Radius, Polyester Resin.

* Add suffix "V" to specify vinyl ester resin, add "SR" to specify strut as alternating rungs, add "MR" to specify Marine rungs

Ordering Information Covers:



Example: CX1812
 C Style Cover, Horizontal Cross, 18" Wide, 12" Radius, Polyester Resin

* Add suffix "V" to specify Vinyl ester resin

STRAIGHT REDUCERS [RS]

STRAIGHT REDUCERS

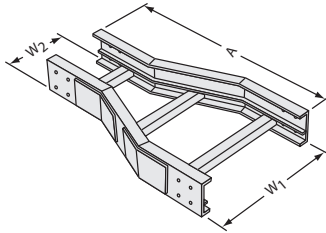

STRAIGHT REDUCERS [RS]				
Part Number	W1*	W2*	LC Tray Style A	CZ, BE, CE, CZD Tray Style A
RS0906	09" (229mm)	06" (152mm)	21" (533mm)	33 ³ / ₁₆ " (852mm)
RS1206	12" (305mm)	06" (152mm)	30" (762mm)	41 ¹ / ₁₆ " (1043mm)
RS1209	12" (305mm)	09" (229mm)	21" (533mm)	33 ³ / ₁₆ " (852mm)
RS1806	18" (457mm)	06" (152mm)	30" (762mm)	40 ¹ / ₂ " (1029mm)
RS1809		09" (229mm)		36 ⁷ / ₁₆ " (937mm)
RS1812		12" (305mm)		41 ¹ / ₁₆ " (1043mm)
RS2406	24" (610mm)	06" (152mm)	30" (762mm)	47 ³ / ₄ " (1213mm)
RS2409		09" (229mm)		44 ¹ / ₁₆ " (1121 mm)
RS2412		12" (305mm)		40 ¹ / ₂ " (1029mm)
RS2418	24" (610mm)	18" (457mm)	30" (762mm)	41 ¹ / ₁₆ " (1043mm)
RS3006	30" (762mm)	06" (152mm)		55" (1397mm)
RS3009	30" (762mm)	09" (229mm)		51 ³ / ₈ " (1305mm)
RS3012	30" (762mm)	12" (305mm)	30" (762mm)	47 ³ / ₄ " (1213mm)
RS3018		18" (457mm)		40 ¹ / ₂ " (1029mm)
RS3024		24" (610mm)		41 ¹ / ₁₆ " (1043mm)
RS3606	36" (914mm)	06" (152mm)	30" (762mm)	62 ³ / ₁₆ " (1580mm)
RS3609		09" (229mm)		58 ³ / ₁₆ " (1487mm)
RS3612		12" (305mm)		55" (1397mm)
RS3618	36" (914mm)	18" (457mm)	30" (762mm)	47 ³ / ₄ " (1213mm)
RS3624		24" (610mm)		40 ¹ / ₂ " (1029mm)
RS3630		30" (762mm)		41 ¹ / ₁₆ " (1043mm)

For "Z" style siderail add 4 (102mm) to accommodate the upper flange.

RIGHT & LEFT REDUCERS [RR] OR [RL]

RIGHT REDUCERS

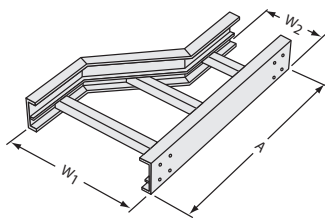

LEFT REDUCERS

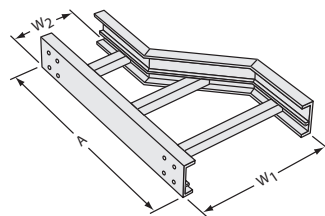

RIGHT & LEFT REDUCERS [RR] OR [RL]				
Part Number	W1*	W2*	LC Tray Style A	CZ, BE, CE, CZD Tray Style A
RR0906 or RL0906	09" (229mm)	06" (152mm)	30" (762mm)	33 ³ / ₄ " (845mm)
RR1206 or RL1206	12" (305mm)	06" (152mm)		40 ¹ / ₂ " (1029mm)
RR1209 or RL1209	12" (305mm)	09" (229mm)		33 ³ / ₄ " (845mm)
RR1806 or RL1806	18" (457mm)	06" (152mm)	30" (762mm)	38" (965mm)
RR1809 or RL1809		09" (229mm)		35" (889mm)
RR1812 or RL1812		12" (305mm)		40 ¹ / ₂ " (1029mm)
RR2406 or RL2406	24" (610mm)	06" (152mm)	39" (991mm)	44" (1118mm)
RR2409 or RL2409		09" (229mm)	39" (991mm)	41" (1041mm)
RR2412 or RL2412		12" (305mm)	30" (762mm)	38" (965mm)
RR2418 or RL2418	24" (610mm)	18" (457mm)	30" (762mm)	40 ¹ / ₂ " (1029mm)
RR3006 or RL3006	30" (762mm)	06" (152mm)	45" (1143mm)	50" (1270mm)
RR3009 or RL3009	30" (762mm)	09" (229mm)	39" (991 mm)	47" (1194mm)
RR3012 or RL3012	30" (762mm)	12" (305mm)	39" (991 mm)	44" (1118mm)
RR3018 or RL3018		18" (457mm)	30" (762mm)	38" (965mm)
RR3024 or RL3024		24" (610mm)	30" (762mm)	40 ¹ / ₂ " (1029mm)
RR3606 or RL3606	36" (914mm)	06" (152mm)	48" (1219mm)	56" (1422mm)
RR3609 or RL3609		09" (229mm)	45" (1143mm)	53" (1346mm)
RR3612 or RL3612		12" (305mm)	45" (1143mm)	50" (1270mm)
RR3618 or RL3618	36" (914mm)	18" (457mm)	39" (991mm)	44" (1118mm)
RR3624 or RL3624		24" (610mm)	30" (762mm)	38" (965mm)
RR3630 or RL3630		30" (762mm)	30" (762mm)	40 ¹ / ₂ " (1029mm)

For "Z" style siderail add 4" (102mm) to accommodate the upper flange

FITTINGS / SPLICE PLATES

Reducers - Part Number System

Reducers are available in three styles:

- Straight,
- Left Hand Offset
- Right Hand Offset.

Strut rungs can be provided at every other run location at no additional cost. Solid bottom fittings are available through special quotation

Ordering Information Fittings:

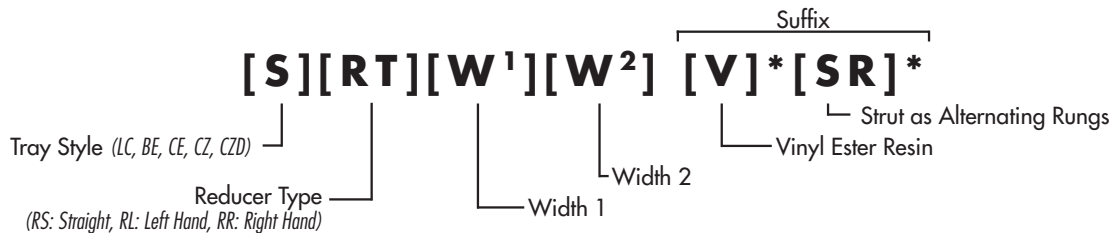

Example: BERS2412
 BE Style Tray, Straight Reducer, 24" Width,
 12" Width, Polyester Resin.

* Add suffix "V" to specify vinyl ester resin, add "SR" to specify strut as alternating rungs

Ordering Information Covers:



Example: CRS2412
 C Style Cover, Straight Reducer, 24" Width, 12" Width, Polyester Resin

* Add suffix "V" to specify Vinyl ester resin

SPLICE PLATES

The COPE-GLAS Cable Tray System offers a full line of fiberglass accessories to suit any application. All accessories must be ordered individually to complete the system.

Splice Plates

Splice plates for system assembly come in six variations designed for specific applications: straight, expansion straight, fixed angle horizontal, fixed angle vertical, horizontal adjustable and vertical adjustable. Low Profile (LC) splice plates require six 3/8-inch fasteners while splice plates for standard and deep tray require eight 3/8-inch fasteners. Splice plates and fasteners are sold separately and

are not provided with straight sections or fittings. The part numbers shown are for polyester splice plates. To specify vinyl ester splice plates, add the suffix "V" to the part number. All Low Profile splice plate part numbers are designated with an "L" prefix.

Example: LS12

Splice plates are shown on the next page.

STRAIGHT SPLICE PLATES

Used for tray-to-tray or tray-to-fitting connections.

Mid Span (Part Numbers: S12-MID)

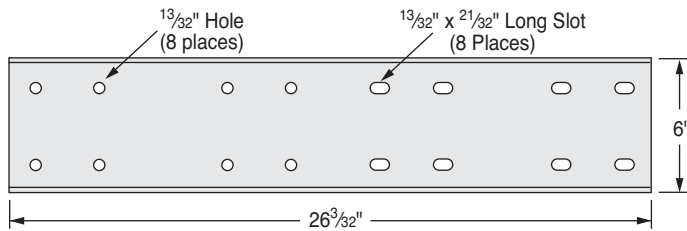

Note: The S12-MID is for use with BE and CE Style Fiberglass Cable Tray

Standard (Part Numbers: S12)

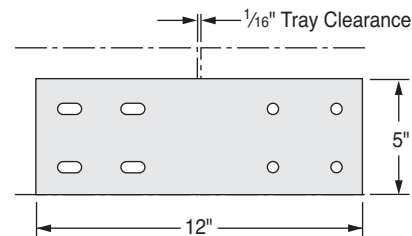

Low Profile (Part Numbers: LS12)

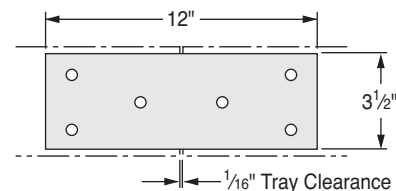

EXPANSION SPLICE PLATES

Used to accommodate thermal expansion/contraction of extended straight tray runs. The following table should be used as a guideline in determining the number of expansion splice plates needed for your application.

EXPANSION SPLICE PLATES

Temperature Differential Deg. F	Tray Length for 1" Expansion	Max Distance Between Expansion Splices
25°	667 ft.	417 ft.
50°	333 ft.	208 ft.
75°	222 ft.	139 ft.
100°	167 ft.	104 ft.
125°	133 ft.	83 ft.
150°	111 ft.	69 ft.
175°	95 ft.	59 ft.

The 1 inch slotted holes in each expansion connector allow 3/8" total expansion or contraction.

Standard (Part Numbers: ES12)

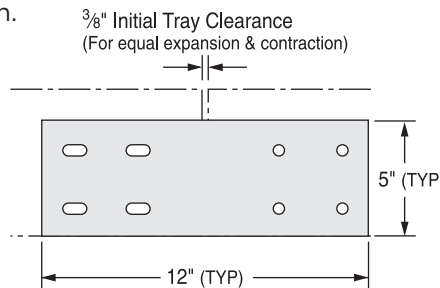

Low Profile (Part Numbers: LES12)

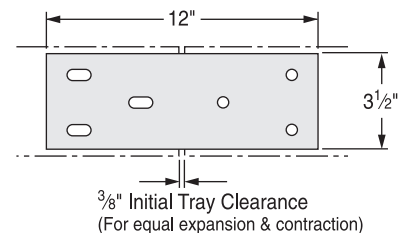

FIXED ANGLE HORIZONTAL SPLICE PLATES

Often field situations necessitate unplanned changes in the horizontal or vertical direction of a cable tray run. Fixed angle and adjustable splice plates provide a means to make horizontal and vertical direction changes in the field. These splice plates may also be used to fabricate special fittings.

Used for 90°, 45°, and 22.5° horizontal direction changes.

Standard (Part Numbers: H90, H45, H22.5)

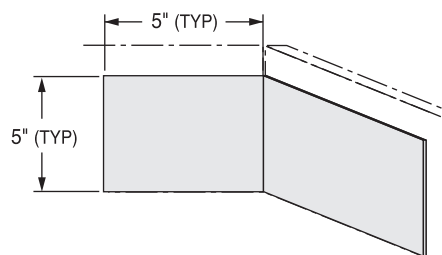

Low Profile (Part Numbers: LH90, LH45, LH22.5)

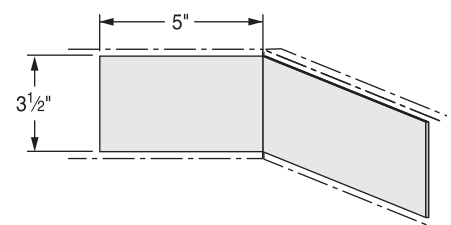

SPLICE PLATES & HARDWARE

FIXED ANGLE VERTICAL SPLICE PLATES

Used for 90°, 45°, and 22.5° vertical direction changes.

Standard (Part Numbers: V90, V45, V22.5)

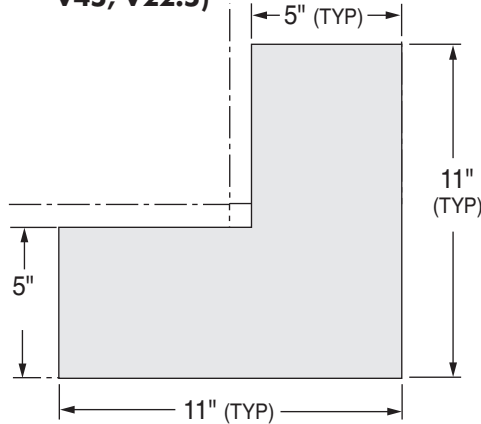

Low Profile (Part Numbers: LV90, LV45, LV22.5)

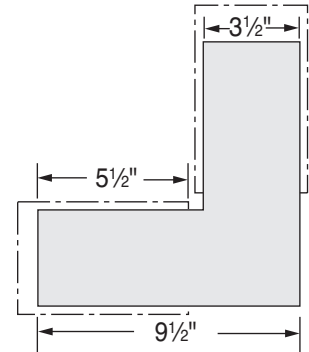

ADJUSTABLE HORIZONTAL SPLICE PLATES

Used for variable horizontal direction changes.

Standard (Part Number: H12)

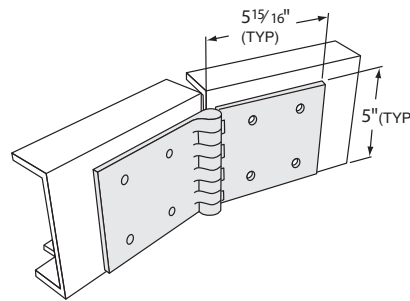

Low Profile (Part Number: LH12)

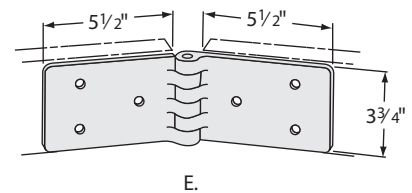

ADJUSTABLE VERTICAL SPLICE PLATES

Used for variable vertical direction changes.

Standard (Part Number: V12)

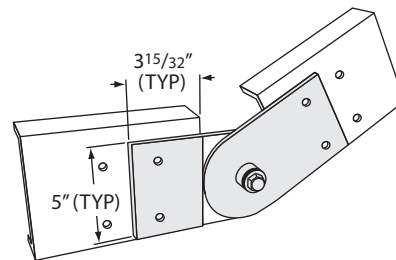

Low Profile (Part Number: LV12)

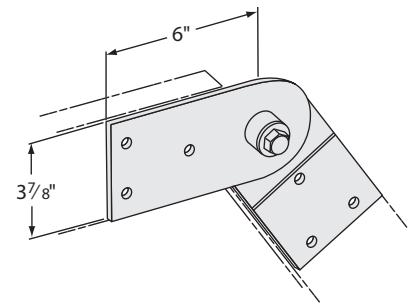

CABLE TRAY HARDWARE

The COPE-GLAS cable tray system offers four types of splice plate fasteners; Fiberglass Encapsulated 316 Stainless Steel, Standard 316 Stainless Steel, Silicon Bronze and Monel. Each bolt set with the exception of the fiberglass encapsulated hardware includes one bolt, one nut, and two washers. The fiberglass encapsulated hardware includes molded collars which act as washers and provide a smooth sealing surface. It is recommended that all splice plate fasteners be installed with a hex head socket wrench and torqued to a maximum 15 ft./lbs.

CABLE TRAY HARDWARE

Part Numbers	Size	Type
FECNBSS	3/8-16 x 1"	Fiberglass Encapsulated
SSNBW2-316	3/8-16 x 1"	316 Stainless Steel
SBNBW2	3/8-16 x 1"	Silicon Bronze
MONBW2	3/8-16 x 1"	Monel

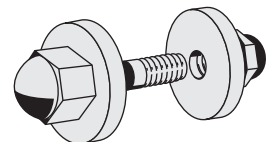

TRAY COVERS AND ACCESSORIES

RIVET [NDR1]

Nylon Drive Rivet is used to secure cover or barrier strip to tray.

Part Number: NDR1

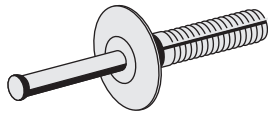

COVER CLAMP [CC1]

PVC coated steel cover clamp designed for use with "Z" profile tray and fittings.

Part Number: CC1

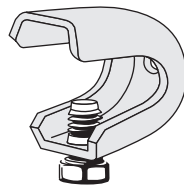

COVER CLAMP [CCE]

Fiberglass cover clamp designed for use with all "E" profile trays and fittings. Available in polyester or vinyl ester. To specify vinyl ester, add suffix "V" to part number.

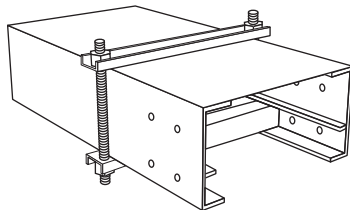

Part No.	Tray Width	Part No.	Tray Width
CCE06	06"	CCE24	24"
CCE09	09"	CCE30	30"
CCE12	12"	CCE36	36"
CCE18	18"		

FIBERGLASS BOLT

1/2"-13 x 2 vinyl ester hex head bolt for use with hold down clamps.

Part Number: 500PU-200

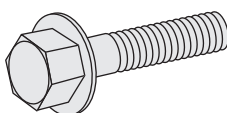

HOLD DOWN PACKAGE

The Hold Down Package consists of the necessary components for securing COPE-GLAS tray to strut or wall brackets. The Hold Down Package includes one each of the following items; HD4AB (hold down clamp), 500PU-200 (1/2"-13 x 2 fiberglass bolt) and 500PU-CN (1 1/2" strut nut). The components are also available individually. Installation procedures are located in the installation Procedures Section of this catalog

Part Number: HDBLNT

Combination Hold-Down Clamp and Expansion Guide

Hold-Down side secures and prevents lateral movement of cable tray while expansion side allows for thermal expansion and contraction of cable tray.

Part Number: HD4AB

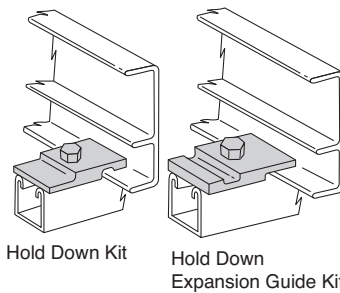

END PLATES

To order appropriate End Plate, see chart. To specify vinyl ester, add suffix "V" to part number (hardware not included).

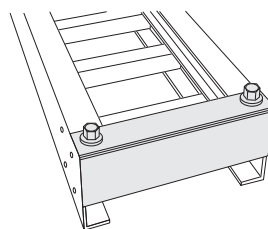

Tray Width	"LC"	"CZ"	"BE/CE"
06"	EPL06	EPZ07	EPE06
09"	EPL09	EPZ09	EPE09
12"	EPL12	EPZ12	EPE12
18"	EPL18	EPZ18	EPE18
24"	EPL24	EPZ24	EPE24
30"	EPL30	EPZ30	EPE30
36"	EPL36	EPZ36	EPE36

FLOOR & PANEL FLANGE

Available in polyester and vinyl ester resin. To specify vinyl ester, add suffix "V" to part number.

Part Numbers: LF400, F400

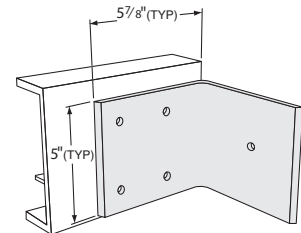

BARRIER STRIP

Barrier strip is supplied in ten foot lengths and is intended for field installation unless otherwise indicated. For securing barrier strip to tray, we recommend the use of Nylon Drive Rivets (Part #NDR1) which require field drilling or Adjustable Divider Clamps (Part ADC1). Barrier strip is available in polyester and vinyl ester resin types. To specify vinyl ester, add suffix "V" to part number.

Example: RGBS4V

Tray Style	Part Number	Dimensions
Low Profile	RGBS3	3" x 2" x 3/16"
Basic	RGBS4	4" x 2" x 3/16"
Deep	RGBS6	6" x 2" x 3/16"

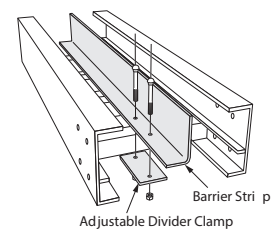

ADJUSTABLE DIVIDER CLAMP

The Adjustable Divider Clamp makes locating the barrier strip a snap. The ADC is available in polyester and vinyl ester resin. To specify vinyl ester, add suffix "V" to part number. Two clamps per ten foot section of barrier strip are recommended.

Tray Style	Part Number
Low Profile	LADC1
Basic	ADC1
Deep	ADC1

COPE-GLAS™ CABLE TRAY SYSTEM

ACCESSORIES

DROP OUTS

Drop Outs are easily fastened to tray rungs with two Nylon Drive Rivets (NDR1). Nylon Drive Rivets are separate order items. To specify vinyl ester, add suffix "V" to part number.

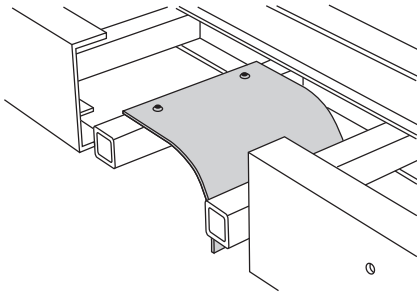

Tray Width	Part Number
06"	D006
09"	D009
12"	D012
18"	D018
24"	D024
30"	D030
36"	D036

COVER STAND-OFFS

Cover Stand-Offs secure cable tray cover to tray or fittings while providing a ventilation gap for cables. The S0200 is designed to be used with all "Z" and "E" profile cable trays. It is supplied with a threaded fiberglass stand-off and two 3/8" diameter, non-metallic bolts (375PU-125). The S0200 requires field drilling. Five pairs of clamps are recommended per ten foot length of cable tray cover.

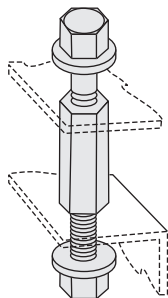

CONDUIT TO CABLE TRAY CLAMP

The Cope-Glas Conduit to Cable Tray Clamp allows a smooth transition for electrical conduits to Cope-Glas Cable Tray. The clamp is available in either polyester or vinyl ester and is adjustable to accommodate any entry angle. This clamp will work with all Cope-Glas tray styles. To order, specify the correct conduit size. For vinyl ester, add the suffix "V" to the part number.

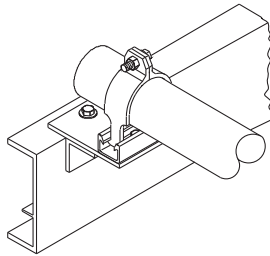

Conduit Size	Part Number	Conduit Size	Part Number
1/2"	CG-CCB-050	2"	CG-CCB-200
3/4"	CG-CCB-075	2 1/2"	CG-CCB-250
1"	CG-CCB-100	3"	CG-CCB-300
1 1/4"	CG-CCB-125	4"	CG-CCB-400
1 1/2"	CG-CCB-150		

TRAY FLANGE HANGER

THE COPE-GLAS Flange Hanger is recommended when space requirements make conventional tray hanging and supporting methods impractical. Flange Hanger has a 375 lb. Load rating with a 2.0 safety factor. To specify vinyl ester, add suffix "V" to part number.

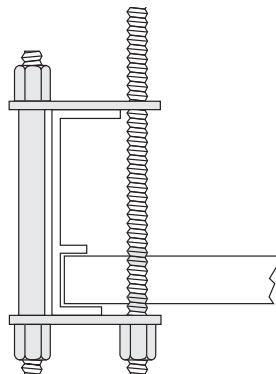

Part Number	Tray Style
RGFH1	Low Profile
RGFH2	E Profile

WALL SUPPORT BRACKETS

Constructed of Aickinstrut fiberglass components, Wall Support Brackets are an alternative tray hanging system. The Aickinstrut product line offers a complete line of fasteners that can be used with the wall brackets in many different tray clamping schemes. Installation guidelines for wall brackets are located in the installation Procedures Section of this catalog. To specify vinyl ester, add suffix "V" to part number.

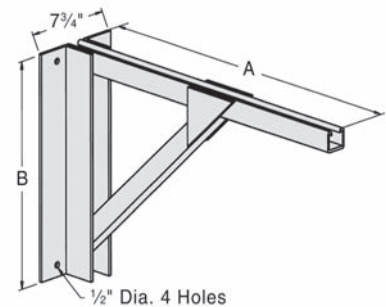

Part No.	Tray Width	Dim. A	Dim. B
CTB06A	06"	11"(279mm)	10"(254mm)
CTB09A	09"	14"(356mm)	12"(305mm)
CTB12A	12"	17"(432mm)	13"(330mm)
CTB18A	18"	23"(584mm)	16"(406mm)
CTB24A	24"	29"(737mm)	19"(483mm)
CTB30A	30"	35"(889mm)	22"(559mm)
CTB36A	36"	41"(1041mm)	25"(635mm)

MARINE RUNG

The marine rung may be specified for several tray components by adding MR to the part number. The marine rung is shown below.

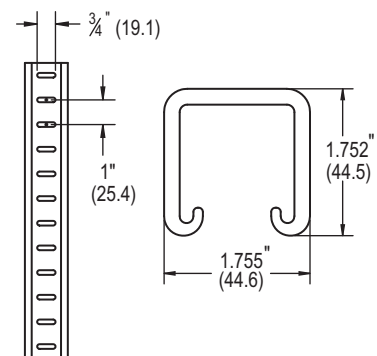

AICKINSTRUT® SUPPORT SYSTEMS

AICKINSTRUT® CHANNEL

Aickinstrut is commonly used as a support system for cable tray, structural piping and electrical conduit. Aickinstrut is available in three profiles (light duty, heavy duty, and back-to-back), and can be supplied in either polyester or vinyl ester resin. Aickinstrut heavy duty and light duty channels are also available slotted (1" long x 3/8" diameter). The standard channel lengths are ten and twenty feet but special lengths are available upon request. For load/deflection information and installation guidelines, refer to the Installation Procedures Section of this catalog.

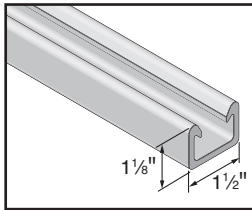

LIGHT DUTY CHANNEL

Part Number	Design	Resin System
20P-1000	Solid	Polyester
20V-1000	Solid	Vinyl Ester
20P-1200	Slotted	Polyester
20V-1200	Slotted	Vinyl Ester

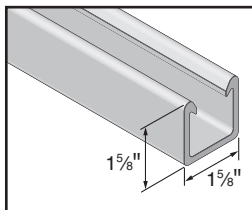

HEAVY DUTY CHANNEL

Part Number	Design	Resin System
20P-2000	Solid	Polyester
20V-2000	Solid	Vinyl Ester
20P-2200	Slotted	Polyester
20V-2200	Slotted	Vinyl Ester

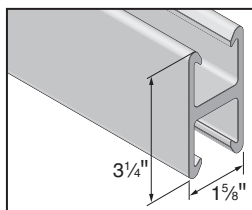

BACK-TO-BACK CHANNEL*

Part Number	Resin System
20P-2100	Polyester
20V-2100	Vinyl Ester

* Add "-SL" to the part number for slotted strut.

FIBERGLASS ALL-THREAD ROD

Fiberglass all-thread rods are an excellent choice for hanging and fastening Aickinstrut Channel. Aickinstrut all-thread rods are available in five sizes: 3/8", 1/2", 5/8", 3/4", and 1". All Aickinstrut all-thread rods are manufactured from pultruded vinyl ester resin and are gray in color. The standard rod lengths are four and eight feet.

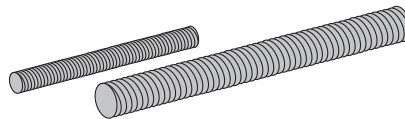

FOUR FOOT LENGTHS

Part Number	Size (in.)
200-3827	3/8 - 16 x 48
20V-2100	1/2 - 13 x 48
200-3829	5/8 - 11 x 48
200-3830	3/4 - 10 x 48
200-3831	1 - 8 x 48

EIGHT FOOT LENGTHS

Part Number	Size (in.)
200-3827-96	3/8 - 16 x 96
200-3828-96	1/2 - 13 x 96
200-3829-96	5/8 - 11 x 96
200-3830-96	3/4 - 10 x 96
200-3831-96	1 - 8 x 96

AICKINSTRUT® ROD COUPLERS

Rod couplers are an excellent means for extending Aickinstrut FRP all-thread rods beyond their standard lengths. All Aickinstrut rod couplers are manufactured from glass-reinforced polyurethane and are colored gray.

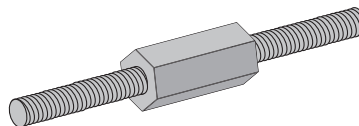

Part Number	Size (in.)	Length (in.)	Shear (lbs.)*
200-3840	3/8 - 16	2 1/4	800
200-3841	1/2 - 13		870
200-3842	5/8 - 11		1500
200-3843	3/4 - 10		1500

*Thread shear values shown represent a 3:1 safety factor.

ALL-THREAD HEX FLANGE NUTS

Hex flange nuts are manufactured from glass-reinforced polyurethane resin and are available in four sizes.

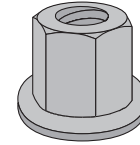

Part Number	Size (in.)	Thread Shear (lbs)*	Torque
375PU-FN-000	3/8 - 16	500	10 in./lbs.
500PU-FN-000	1/2 - 13	1200	3 ft./lbs.
625PU-FN-000	5/8 - 11	2200	8 ft./lbs.
750PU-FN-000	3/4 - 10	2900	12 ft./lbs.

*Thread shear values shown represent a 3:1 safety factor.

ALL-THREAD WASHERS

COPE-GLAS All-Thread Washers are flat fiberglass washers for use with FRP all-thread rods. All-thread rod washers are 1/4" thick with a 1/e" diameter and are available in polyester or vinyl ester resin. To order vinyl ester, add the suffix "V" to the part number.

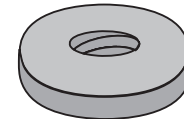

Part Number	All-Thread Rod Size (in.)
WR375	3/8
WR500	1/2
WR625	5/8
WR750	3/4

* Add "-SL" to the part number for slotted strut.

CHANNEL CAPPING STRIP

Channel capping strip is made from PVC and is provided in 10 foot lengths. Part Number 20E-5000

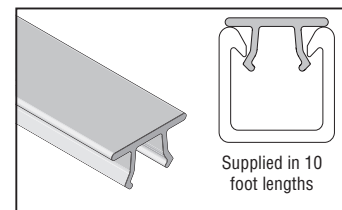

Supplied in 10 foot lengths

COPE-GLAS™ CABLE TRAY SYSTEM

AICKINSTRUT® SUPPORT SYSTEMS

AICKINSTRUT® CHANNEL NUTS

Aickinstrut Channel Nuts can be used to attach pipe straps, channel fittings or COPEGLAS holdown clamps to Aickinstrut Channel. The standard duty channel nuts are designed for applications where high thread shear values are not required. The heavy duty channel nuts are designed for applications that require high thread shear and torque values.

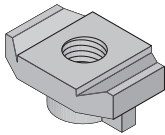

STANDARD DUTY

Part Number	Size (in.)	Thread Shear (lbs.)*	Torque (ft./lbs)
375PU-CN	3/8- 16	460	2
500PLJ-CN	1/2	460	3

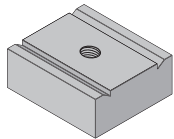

HEAVY DUTY

Part Number	Size (in.)	Thread Shear (lbs.)*	Torque (ft./lbs)
375PU-CNJHD	3/8- 16	1400	8
500PU-CNHD	1/2-13	1400	8

*Thread shear values shown a 3:1 safety represent factor.

HANGER ROD BEAM CLAMPS

COPE-GLAS Hanger Rod Beam Clamps are molded from glass-reinforced polyurethane and are available in three sizes: 3/8", 1/2" and 5/8".

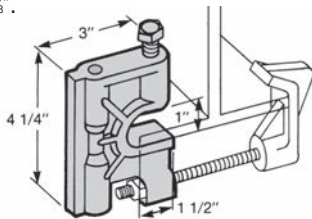

Part Number	Size (in.)	Thread Shear (lbs.)*	Torque (ft./lbs)
RGBC-1	3/8	500	10
RGBC-2	1/2	500	10
RGBC-3	5/8	500	10

*Thread shear values shown represent a 3:1 safety factor.

FIBERFAST BOLTS

Fiberfast bolts are available in three diameters (3/16", 3/8" & 1/2") and are injection molded from glass-reinforced polyurethane resin.

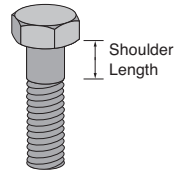

Part Number	Size (in.)	Thread Shear (lbs.)*	Shank Shear (lbs.)	Torque (ft./lbs)
300PU-100	3/16 x 1	225	450	3
300PU-125	3/16 x 1 1/4	225	450	3
300PU-150	3/16 x 1 1/2	225	450	3
375PU-125	3/8 x 1 1/4	250	470	3
375PU-150	3/8 x 1 1/2	250	470	3
375PU-200	3/8 x 2	250	470	3
375PU-250	3/8 x 2 1/2	250	470	3
375PU-300	3/8 x 3	250	470	3
500PU-125	1/2 x 1 1/4	450	870	8
500PU-200	1/2 x 2	450	870	8
500PU-250	1/2 x 2 1/2	450	870	8
500PU-300	1/2 x 3	450	870	8

*Thread shear and shank shear values shown represent a 3:1 safety factor.

NON-METALLIC U-BOLTS

Non-metallic U-Bolts are injection molded from glass-reinforced polyurethane and are available in sizes from 1/2" - 4" diameter.

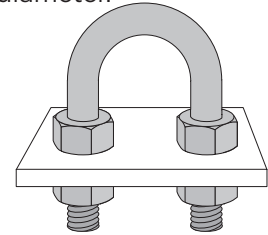

Part Number	Size (in.)	Load (lbs)*	Torque (ft./lbs)
UB-050	1/2	135	40
UB-075	3/4	135	40
UB-100	1	135	40
UB-125	1 1/4	135	40
UB-150	1 1/2	135	40
UB-200	2	135	80
UB-250	2 1/2	135	80
UB-300	3	135	80
UB-350	3 1/2	153	80
UB-400	4	135	80

*Torque and load values shown represent a 3:1 safety factor.

K. RIGID PIPE CLAMPS

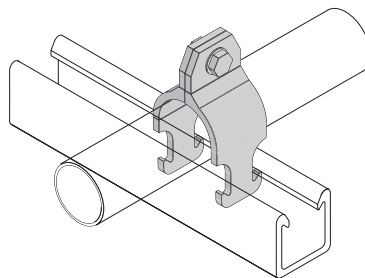

Aickinstrut Rigid Pipe Clamps resemble the more traditional style of pipe clamps. These clamps are made from glass reinforced polyurethane and are sized based on the pipe inside diameter or nominal size.

Part Number	Nominal Size (in.)	PVC Sch. 80 and Rigid	Design Load (lbs)*		FRP Bolt Size (in.)	Torque
			Type 1	Type 2		
PCR-050	1/2	.840	180	25	1/4x1	5in/lbs
PCR-075	3/4	1.050	180	25	1/4x1	5in/lbs
PCR-100	1	1.315	180	25	1/4x1	5in/lbs
PCR-125	1 1/4	1.660	180	25	1/4x1	5in/lbs
PCR-150	1 1/2	1.900	180	25	1/4x1	5in/lbs
PCR-200	2	2.375	180	25	1/4x1	5in/lbs
PCR-300	3	3.500	220	50	3/8 x 1 1/4	3 ft/lbs
PCR-400	4	4.500	250	100	3/8 x 1 1/4	3 ft/lbs
PCR-600	6	6.625	250	100	3/8 x 1 1/4	3 ft/lbs

*Design loads shown represent a safety factor 3:1

Aickinstrut Channel Fittings Legend: P Series Fittings are Gray Polyester, V Series Fittings are Beige Vinyl Ester, PU Series Fittings are Gray Polyurethane,

Note: All fittings are provided with 1/8" holes which accommodate 3/8" hardware

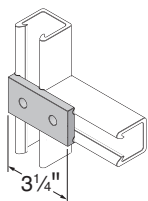
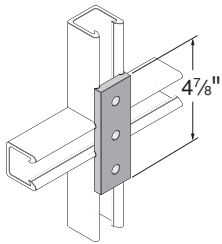
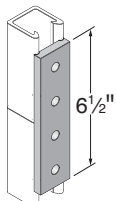
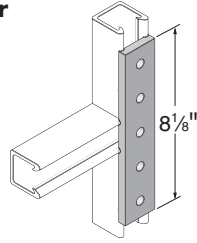
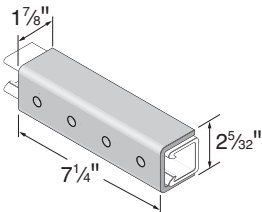
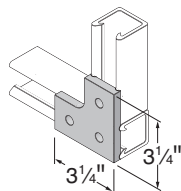
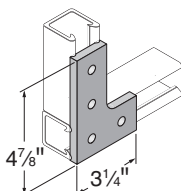
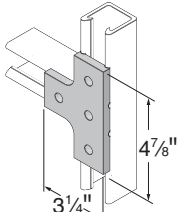
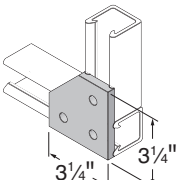
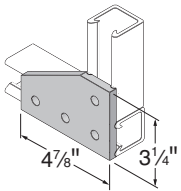
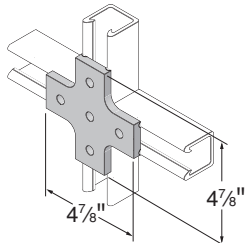
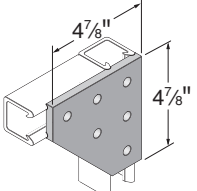
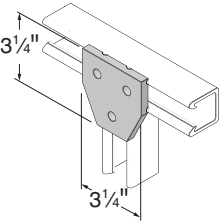
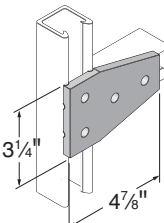
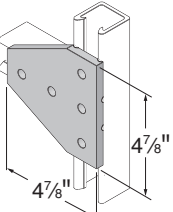
<p>Part Number 20P-2500 20V-2500</p> 	<p>Part Number 20P-2502 20V-2502</p> 	<p>Part Number 20P-2504 20V-2504</p> 
<p>Part Number 20P-2506 20V-2506</p> 	<p>Part Number 50PU-2616</p> 	<p>Part Number 20P-2508 20V-2508</p> 
<p>Part Number 20P-2510 20V-2510</p> 	<p>Part Number 20P-2512 20V-2512</p> 	<p>Part Number 20P-2514 20V-2514</p> 
<p>Part Number 20P-2516 20V-2516</p> 	<p>Part Number 20P-2518 20V-2518</p> 	<p>Part Number 20P-2520 20V-2520</p> 
<p>Part Number 20P-2522 20V-2522</p> 	<p>Part Number 20P-2524 20V-2524</p> 	<p>Part Number 20P-2526 20V-2526</p> 

COPE-GLAS™ CABLE TRAY SYSTEM

AICKINSTRUT® SUPPORT SYSTEMS

Aickinstrut Channel Fittings Legend: P Series Fittings are Gray Polyester, V Series Fittings are Beige Vinyl Ester, PU Series Fittings are Gray Polyurethane,

Note: All fittings are provided with $\frac{1}{32}$ " holes which accommodate $\frac{3}{8}$ " hardware

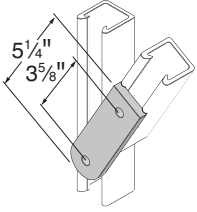
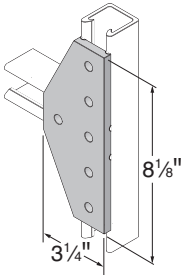
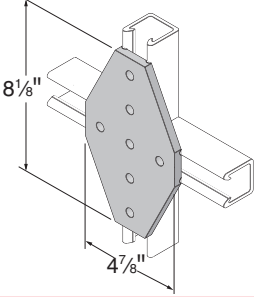
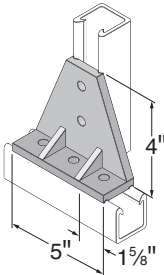
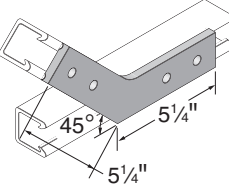
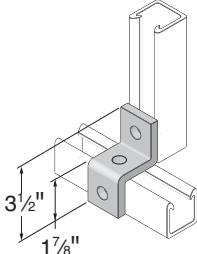
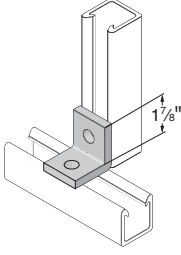
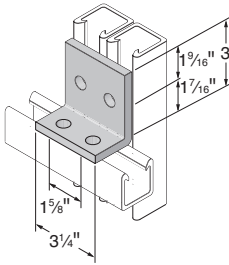
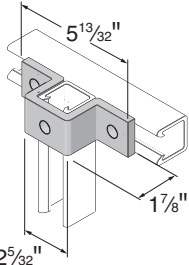
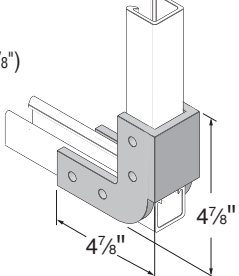
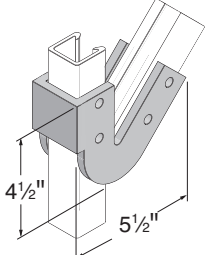
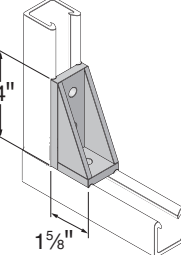
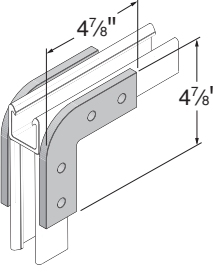
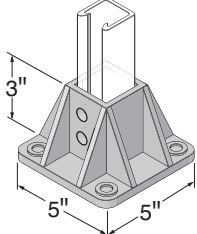
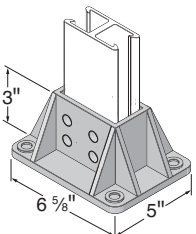
<p>Part Number 20P-2528 20V-2528</p> 	<p>Part Number 20P-2530 20V-2530</p> 	<p>Part Number 20P-2534 20V-2534</p> 
<p>Part Number 50PU-2538</p> 	<p>Part Number 20P-2540 20V-2540</p> 	<p>Part Number 50PU-2611</p> 
<p>Part Number 50PU-2611-SP</p> 	<p>Part Number 20P-2542 20V-2542</p> 	<p>Part Number 50PU-2613</p> 
<p>Part Number 50PU-2008 (1 5/8")</p> 	<p>Part Number 50PU-2045 (1 5/8")</p> 	<p>Part Number 50PU-2636¹ (Flat, without splines) 50PU-2636A² (Splines on long side) 50PU-2636B³ (Splines on short side) 50PU-2936⁴ (Splines on both sides)</p> 
<p>Part Number 50PU-2090 (1 5/8")</p> 	<p>Part Number 20PU-5853 (1 5/8") 20PU-5855 (1 1/8")</p> 	<p>Part Number 20PU-5903 (3 1/4") 20PU-5905 (2 1/4")</p> 

FIBERGLASS CHANNEL

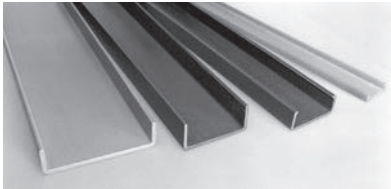

Fiberglass channel is designed to carry light wiring or tubing loads where a transition from cable tray to individual control points are required. All straight sections are offered in solid or punched construction and are supplied in ten and twenty foot lengths. COPE-GLAS Channel is available in polyester or vinyl ester resin. Contact factory for vinyl ester channel pricing. Channel fittings are supplied completely assembled from the factory. Special channel fittings that are not standard catalog items are available upon request. Channel splice plates and fasteners are separate order items.

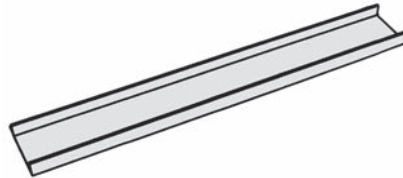
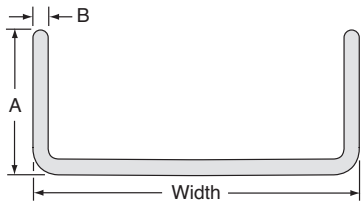

SOLID AND PUNCHED STRAIGHT CHANNEL (10FT. & 20FT. LENGTH)

Solid	Punched	Width	"A"	"B"
CH2-(L)	-Not Avail-	2" (51mm)	1 13/16" (31mm)	1/8" (3mm)
CH3-(L)	CH3-(L)P	3" (76mm)	7/8" (22mm)	1/4" (6mm)
CH4-(L)	CH4-(L)P	4" (102 mm)	1 3/8" (35mm)	3/16" (5mm)
CH6-(L)	CH6-(L)P	6" (152mm)	1 5/8" (41mm)	1/4" (6mm)
CH8-(L)	CH8-(L)P	8" (203mm)	2 3/16" (56mm)	1/4" (6mm)

Punched channel consists of two rows of 1/2" diameter holes on 12" centers.

CHANNEL FITTINGS [CH]

Solid and punched Channel Fittings are available for all channel widths except 2" (2" punched channel fittings are not available). All fittings are preassembled and do not include splice plates and hardware. Contact factory for dimensional information on 45° Channel Fitting bends.

Unless specified otherwise, smooth radius channel fittings will be supplied wherever possible for all 4" (102mm) and 6" (152mm) widths.

Ordering Information

To create a part number, first insert the fitting type from key shown below. Then substitute the appropriate number for "W", the desired radius for "R" and the degree of bend for "D". Add a "P" suffix to the "W" designation to specify punched channel fittings. Channel Fittings are available in polyester or vinyl ester resin. Polyester is standard, to specify vinyl ester resin, add the suffix "V" to the part number.

Ordering Information:

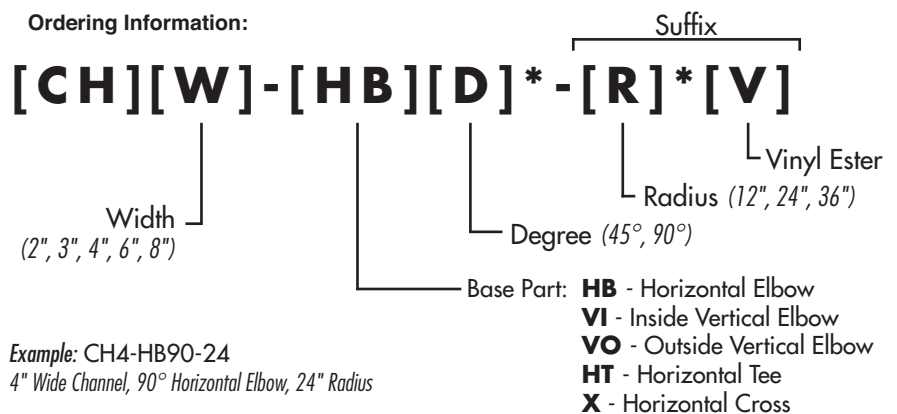

* Radius and degree designations do not apply to tees and crosses.

Note: Connector plates and hardware are not included and must be ordered separately.

FIBERGLASS CHANNEL

COVERS [C]

Covers are used where cable protection is necessary or desired. Covers are available in polyester or vinyl ester resin and are offered in ten foot lengths. To specify vinyl ester resin, add the suffix "V" to the part number.

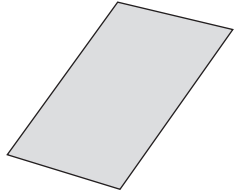

Cover Ordering Information:

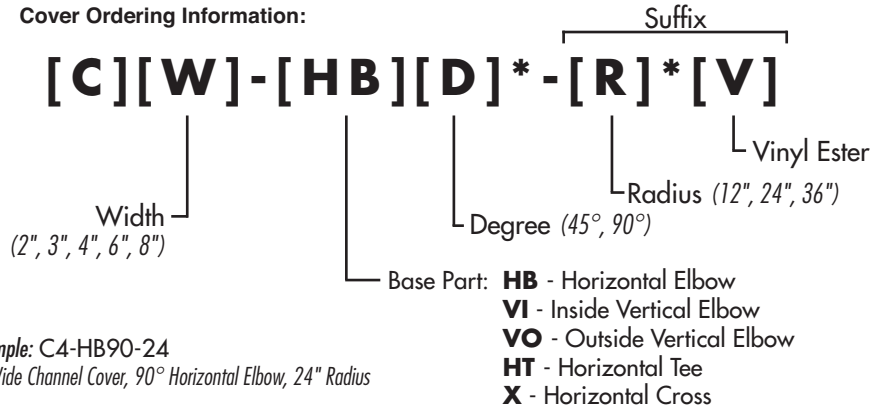

Example: C4-HB90-24
4" Wide Channel Cover, 90° Horizontal Elbow, 24" Radius

* Radius and degree designations do not apply to tees and crosses.

Note: Connector plates and hardware are not included and must be ordered separately.

HORIZONTAL ELBOWS [HB]

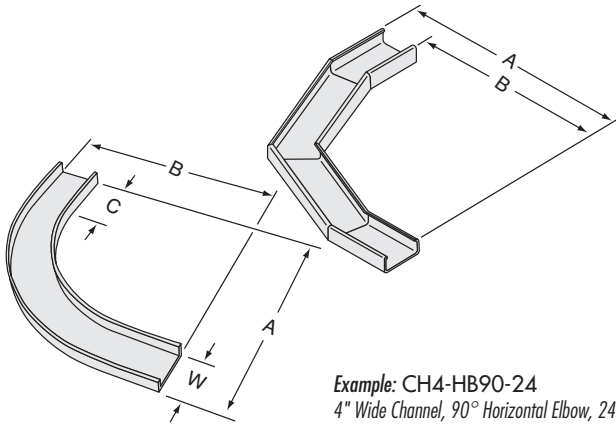

Example: CH4-HB90-24
4" Wide Channel, 90° Horizontal Elbow, 24" Radius

MITERED RADIUS DIMENSIONS

Radius	A	B
12" (305mm)	17" (432mm)+W	17" (432mm)
24" (610mm)	29" (737mm)+W	29" (737mm)
36" (914mm)	41" (1041mm)+W	41" (1041mm)

SMOOTH RADIUS (AVAILABLE ONLY IN 4" AND 6" DIMENSIONS)

Radius	W	A or B	C (straight)
12" (305mm)	4"	20" (508mm)	5"
24" (610mm)	(102mm)	32" (813mm)	(127mm)
12" (305mm)	6"		
24" (610mm)	(152mm)		

FIBERGLASS CHANNEL

INSIDE VERTICAL ELBOW [VI]

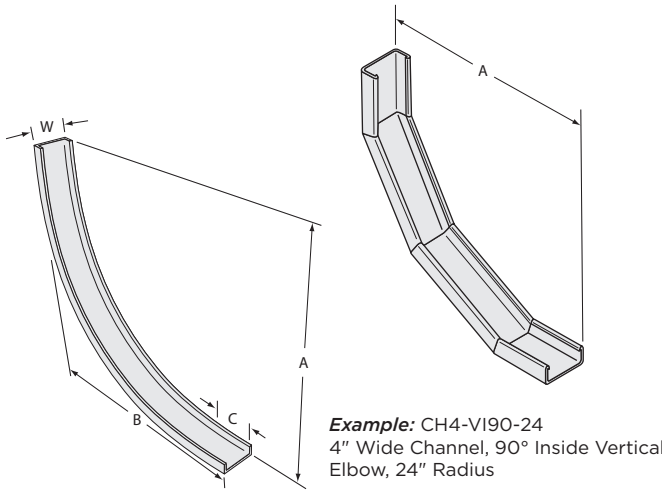

Example: CH4-VI90-24
4" Wide Channel, 90° Inside Vertical Elbow, 24" Radius

MITERED RADIUS DIMENSIONS

Radius	A
12" (305mm)	17" (432mm)
24" (610mm)	29" (737mm)
36" (914mm)	41" (1041mm)

SMOOTH RADIUS (AVAILABLE ONLY IN 4" & 6" WIDTHS)

Radius	W	A or B	C (Straight)
12" (305mm)	4" (102mm)	29½" (740mm)	5" (127mm)
24" (610mm)			
12" (305mm)	6" (152mm)		
24" (610mm)			

OUTSIDE VERTICAL ELBOW [VO]

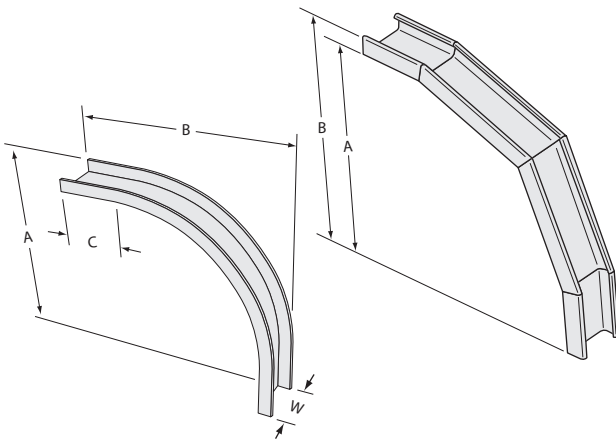

Example: CH4-VO90-24
4" Wide Channel, 90° Outside Vertical Elbow, 24" Radius

MITERED RADIUS DIMENSIONS

Radius	A	B
12" (305mm)	17" (432mm)	17" (432mm) + Flange Height
24" (610mm)	29" (737mm)	29" (737mm) + Flange Height
36" (914mm)	41" (1041mm)	41" (1041mm) + Flange Height

SMOOTH RADIUS (AVAILABLE ONLY IN 4" WIDTHS)

Radius	Channel Width	A or B	C (Straight)
12" (305mm)	4" (102mm)	18½" (460mm)	5" (127mm)
24" (610mm)			
12" (305mm)	6" (152mm)		
24" (610mm)			

HORIZONTAL TEE [HT]

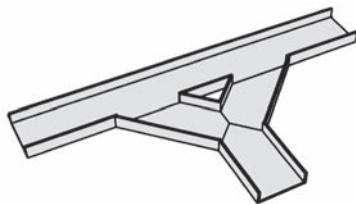

Example: CH4-HT
4" Wide Channel, Horizontal Tee

Horizontal Tees and Crosses are available as part of the COPE-GLAS Channel System. Contact factory for dimensional information.

HORIZONTAL CROSS [X]

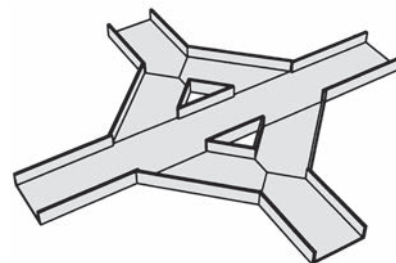

Example: CH4-X
4" Wide Channel, Horizontal Cross

FIBERGLASS CHANNEL - CHANNEL SPLICE PLATES

Channel splice plates are available in seven styles and are made from polyester or vinyl ester resin. All splice plates are pre-drilled and do not include assembly fasteners.

STRAIGHT SPLICE PLATES [SP]



Channel Width	Part Number
2"	CH2-SP
3"	CH3-SP
4"	CH4-SP
6"	CH6-SP
8"	CH8-SP

HORIZONTAL ELBOW SPLICE PLATES [SPH]

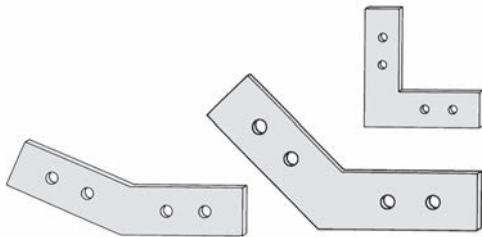

Channel Width	Part Numbers for Given Angle		
	90°	45°	22½°
2"	CH2-SPH90	CH2-SPH45	CH2-SPH22
3"	CH3-SPH90	CH3-SPH45	CH3-SPH22
4"	CH4-SPH90	CH4-SPH45	CH4-SPH22
6"	CH6-SPH90	CH6-SPH45	CH6-SPH22
8"	CH8-SPH90	CH8-SPH45	CH8-SPH22

VERTICAL ELBOW SPLICE PLATES [SPV]

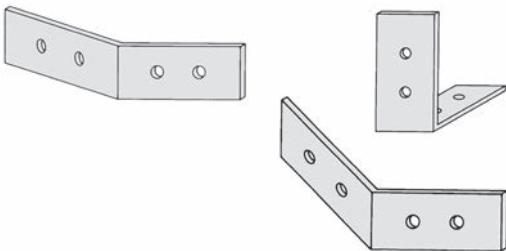

Channel Width	Part Numbers for Given Angle		
	90°	45°	22½°
2"	CH2-SPV90	CH2-SPV45	CH2-SPV22
3"	CH3-SPV90	CH3-SPV45	CH3-SPV22
4"	CH4-SPV90	CH4-SPV45	CH4-SPV22
6"	CH6-SPV90	CH6-SPV45	CH6-SPV22
8"	CH8-SPV90	CH8-SPV45	CH8-SPV22

CHANNEL SPLICE PLATE HARDWARE

Assembly hardware sets include:
 (1) 316 stainless steel 1/4-20 x 3/4" bolt,
 (1) 316 stainless steel 1/4-20 nut and
 (2) 316 stainless steel flat washers.

Assembly hardware is sold individually and not provided with channel straight sections or fittings. Four sets are required for each splice plate.

Part Number: 252075

10

WIRE BASKET

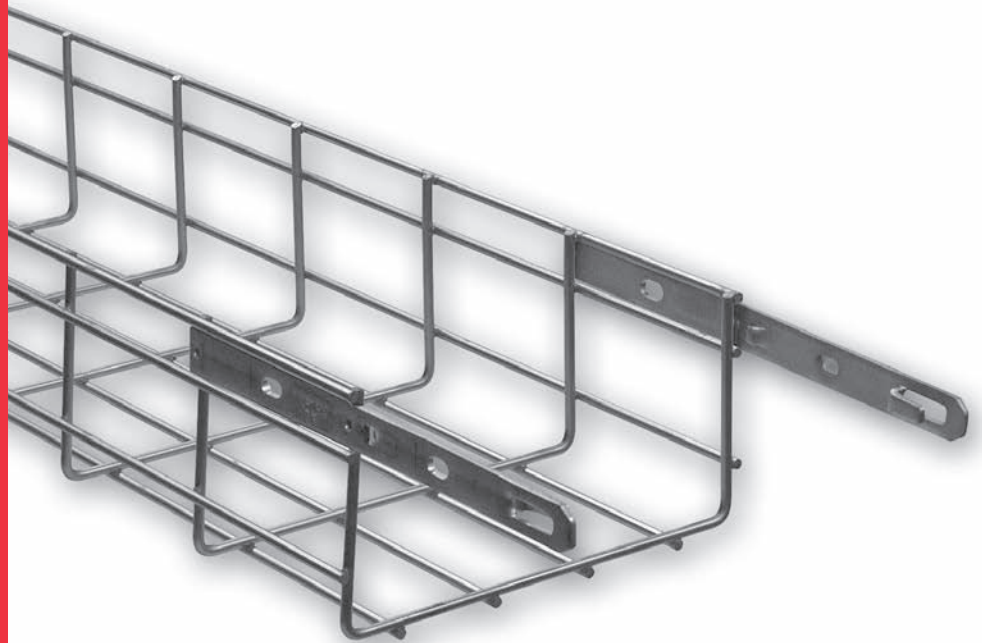

WIRE BASKET SYSTEM

CONTENTS

GENERAL & TECHNICAL INFORMATION

Overview.....	208
Assembly.....	209

WIRE BASKET TRAY

Straight Length	
2" Load Depth.....	210
4" Load Depth.....	211
6" Load Depth.....	212
Bar Connectors.....	213
Connection Hardware Kits.....	214 - 215
Support Brackets.....	216
Drop Rod Clips.....	217
Wall & Ceiling Mounts.....	218
Zed Bracket.....	219
Cantilevers.....	219
Hangers.....	220
Pendants.....	221
Hanging Brackets.....	221 - 223
Pedestal Brackets.....	224

COVERS

Covers.....	225
-------------	-----

ACCESSORIES

Drop Outs.....	225
Tray Dividers.....	225
Blind Ends.....	226
Box Connector.....	226
Brackets.....	227
Wall Sleeve.....	227
Cutting Tool.....	228

FITTINGS

90° Long Radius Bends.....	229
90° Short Radius Bends.....	230 - 231
Standard Tee.....	232
Cross.....	232
Reducer.....	233
Offset.....	233
Risers.....	233

GROUNDING & HARDWARE

Grounding Clips and Clamp.....	234
General Hardware.....	235 - 237

SPECIFICATION INFORMATION

Electrical Grounding Information.....	234
Sample Specification.....	238

PICTORIAL INDEX

STRAIGHT LENGTH

Pages 210 - 212

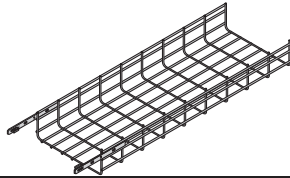

BAR CONNECTORS & HARDWARE

Pages 213 - 215

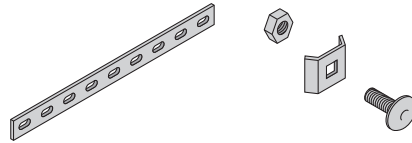

SUPPORT BRACKETS

Page 216

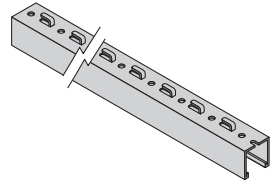

DROP ROD CLIPS

Page 217

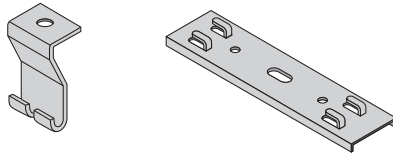

WALL & CEILING MOUNTS

Page 218

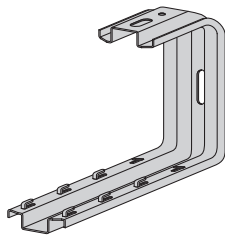

CANTILEVER & ZED BRACKETS

Page 219

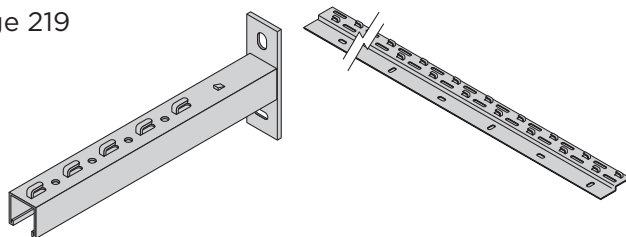

HANGERS & HANGING BRACKETS

Pages 220 - 223

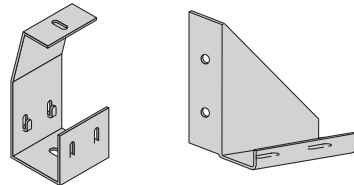

PENDENTS

Page 221

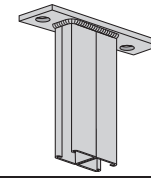

PEDESTAL BRACKETS

Page 224

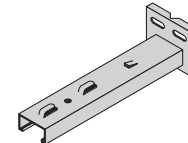

COVERS

Page 225

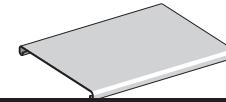

TRAY DIVIDERS AND DROP OUTS

Page 225

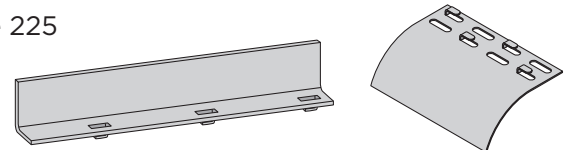

ACCESSORIES

Pages 226 - 227

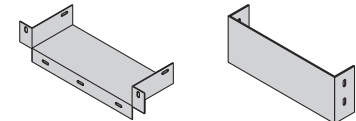

LONG & SHORT RADIUS BANDS

Pages 229 - 231



CROSS & TEE FITTINGS

Page 232

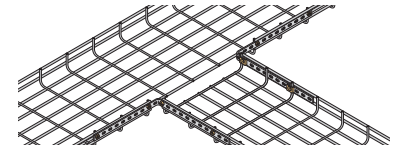

RISER, REDUCER & OFFSET FITTINGS

Page 233

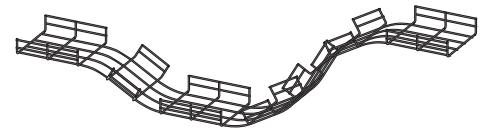

GROUNDING & HARDWARE

Pages 234 - 237

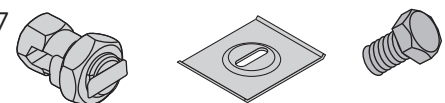

WIRE BASKET SYSTEM

OVERVIEW

PRODUCT DESCRIPTION

Wire basket tray is a welded wire mesh cable management system produced from high strength steel wires. Wire basket tray is produced by first welding a net, forming the channel, and then finishing after fabrication. The 2" x 4" mesh permits continuous airflow to help prevent heat buildup. In addition, this unique open design prevents the buildup of dust, contaminants and bacterial proliferation.

Wire basket tray is produced in standard 10' lengths and is supplied in three channel depths: 2", 4", and 6".

Wire basket tray is offered in nine different widths:

2" (50 mm), 4" (100mm),
6" (150mm), 8" (200mm),
12" (300mm), 16" (400mm),
18" (450mm), 20" (500mm), and
24" (550mm).

Special sizes are available to meet your unique requirements.

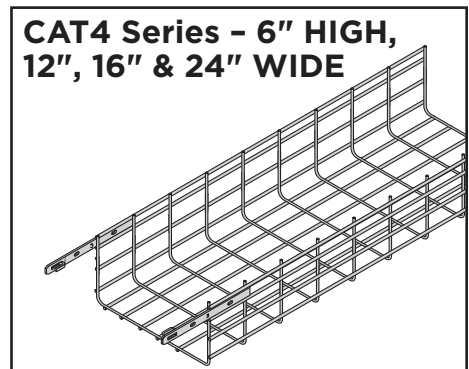
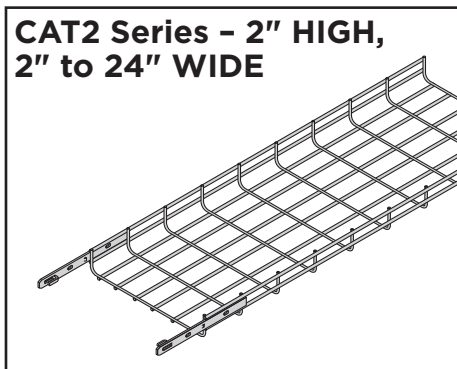

STANDARD FINISH

EG — ELECTRO-PLATED ZINC GALVANIZED - (ASTM B633 TYPE III, SC3 • Thickness: .000472" (12µm))

Electrodeposited zinc coating is suitable for most indoor applications and may be used outdoors in mild environmental conditions.

SPECIAL ORDER FINISHES

HG — HOT DIP GALVANIZED - (ASTM A123 GRD.55 • Thickness: .0002165" (55µm))

Provided by immersing the product in a molten zinc bath. This treatment is most suitable for outdoor applications or situations where increased corrosion resistance is desired.

**SS — 304 TYPE STAINLESS STEEL or
S1 — 316 TYPE STAINLESS STEEL**

Corrosive resistant stainless steel with no additional surface treatment. This material option provides the best corrosion resistance available. Stainless steel is used primarily in marine environments or food processing facilities.

ZD — DICHROMATE - (ASTM B633 Type II, SC3 • Thickness: .000472" (12µm))

An electro-galvanized zinc plate is applied to the steel base metal. Yellow dichromate is applied over the zinc and results in a gold appearance which acts as a nonporous barrier sealant.

OTHER - Powder coating available.

HOW TO ORDER

Part numbers shown in the catalog are for the standard electro-galvanized finish. For special order finishes, add the finish code as a suffix.

EXAMPLE -

CAT2-12SL-120 is electro-galvanized
CAT2-12SL-120-SS is stainless steel

SELF-SPLICING STRAIGHT LENGTHS

The Kwik-Latch splicing system makes connecting wire basket tray fast and simple. The Kwik-Latch, or self splicing bars which come pre-installed on wire basket tray systems, eliminates the need for a typical nut and bolt type connection. For proper grounding of wire basket tray please refer to page 234.

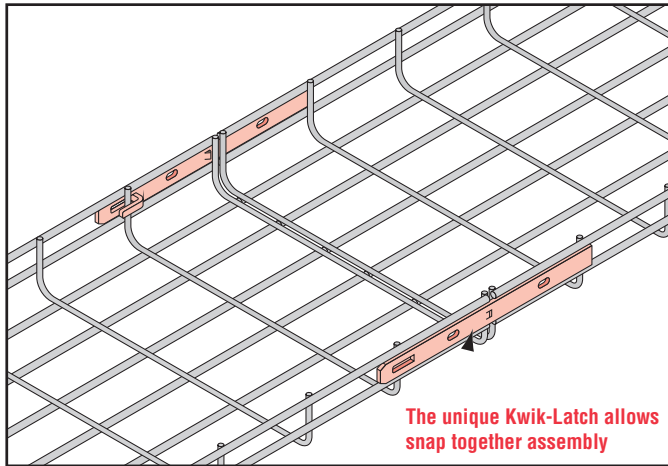

WIRE BASKET ASSEMBLY - CAT2, CAT4, CAT6

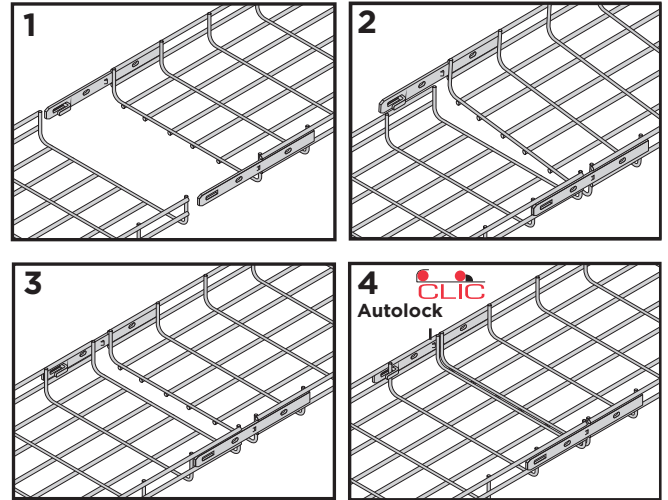

- Step 1** Align the trays as shown.
- Step 2** While raising the rear edge of the male connection, slide the tray forward, but do not engage the locking clip.
- Step 3** Push the rear locking clip over the back edge of the tray.
- Step 4** Slide the tray forward to engage both front and rear locking clips

ACCESSORY ASSEMBLY

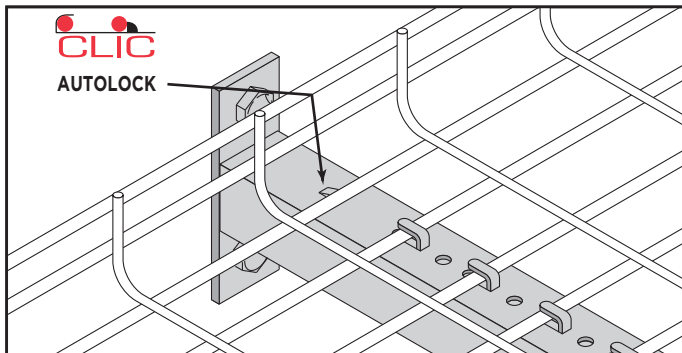

Many of the wire basket accessories feature the unique Autolock. Just slide the tray under the tabs and then push down to engage the Autolock. No tools, bending, or attachments are required for a secure connection.

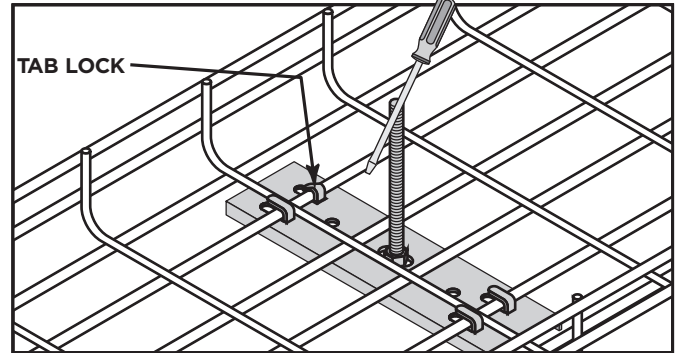
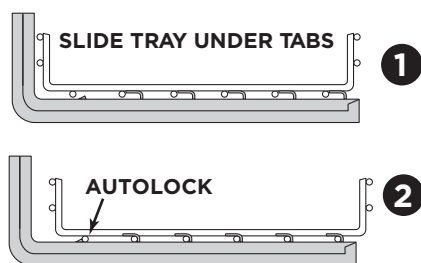

For accessories which use the tab lock, the tray is secured by using a screw driver to gently bend one of the tabs down over the tray.

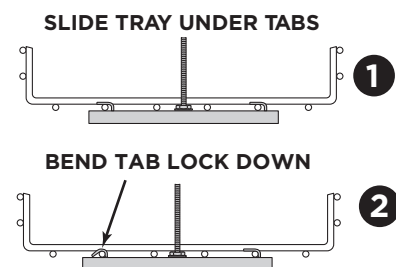

WIRE BASKET SYSTEM

DOUBLE ROD REINFORCED TRAY (2" DEPTH)

DOUBLE ROD REINFORCED TRAY (2" DEPTH) [CAT2-(W)SL-120]

- Double rod reinforced tray is 2" high
- Standard length of tray is 10'
- Standard finish is electro-galvanized (EG)
- No hardware is necessary to connect straight sections
- For continuous grounding use CAT-GC (See page 234)

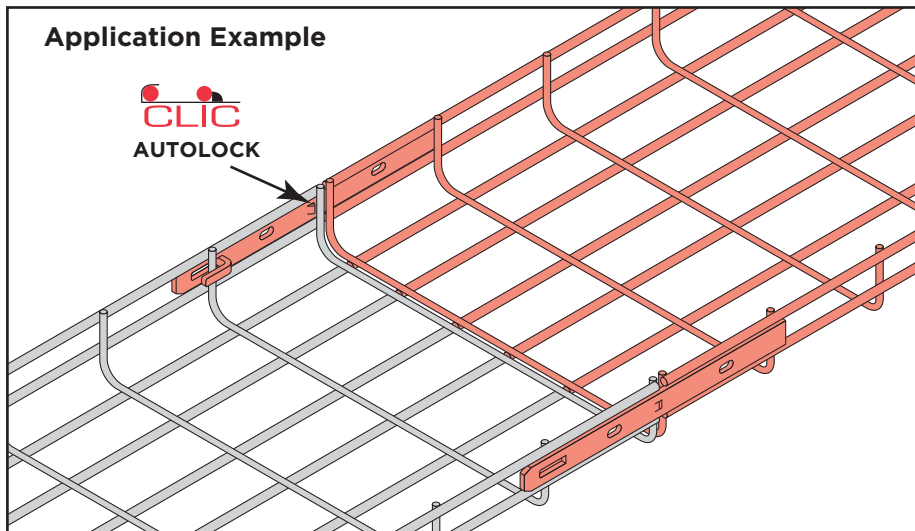
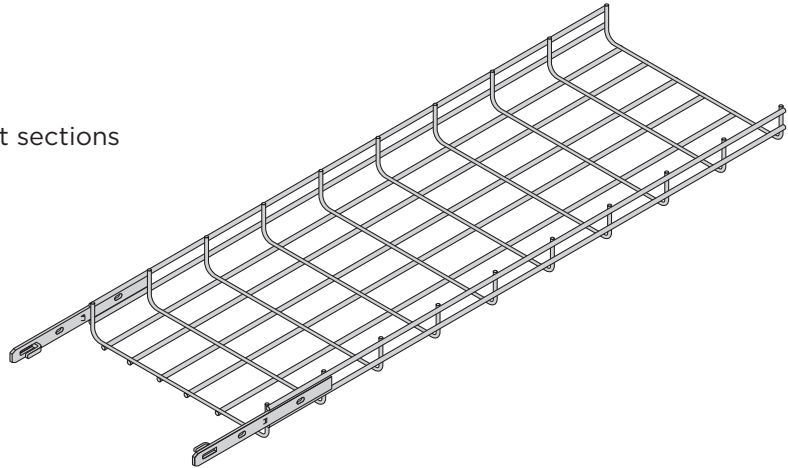

Approvals		Part Description	Width Nominal	Dimensions Wire Dia (in.)	Wt. (piece)	Loading (lb/ft)				
UL	cUL					5' Span	6' Span	8' Span	9' Span	
			CAT2-02SL-120	2" (50mm)	0.177	4.6	60	42	23	19
			CAT2-04SL-120	4" (100mm)	0.177	6.8	60	42	23	19
			CAT2-06SL-120	6" (150mm)	0.177	8.0	60	42	23	19
			CAT2-08SL-120	8" (200mm)	0.197	9.3	89	62	35	27
			CAT2-12SL-120	12" (300mm)	0.197	14.5	89	62	35	27
			CAT2-16SL-120	16" (400mm)	0.236	25.3	149	103	58	46
			CAT2-18SL-120	18" (450mm)	0.236	27.6	149	103	58	46
			CAT2-20SL-120	20" (500mm)	0.236	29.8	149	103	58	46
			CAT2-24SL-120	24" (600mm)	0.236	34.3	149	103	58	46

Load Values are determined by NEMA VE1 testing. Copies of load tests available upon request.

Safety Factor 1.5

TRIPLE ROD REINFORCED TRAY (4" DEPTH)

TRIPLE ROD REINFORCED TRAY (4" DEPTH) [CAT4-(W)SL-120]

- Triple rod reinforced tray is 4" high
- Standard length of tray is 10'
- Standard finish is electro-galvanized (EG)
- No hardware is necessary to connect straight sections
- For continuous grounding use CAT-GC (See page 234)

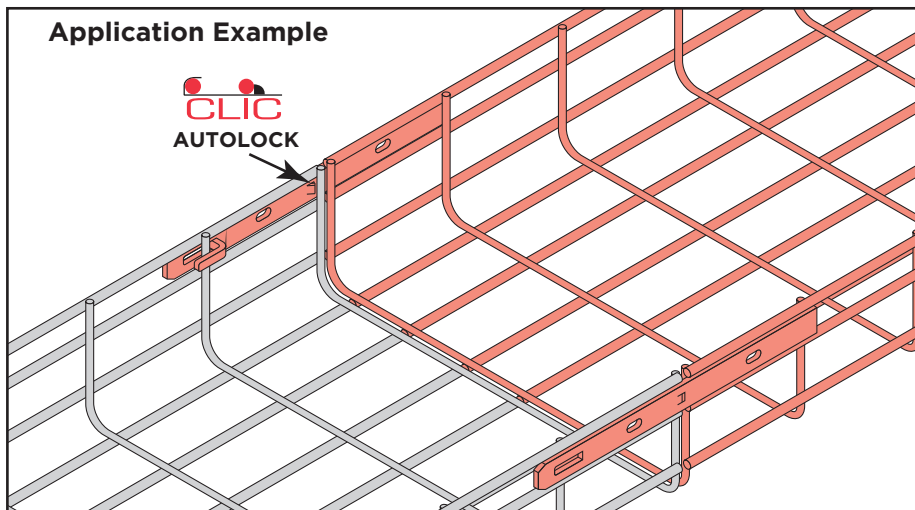
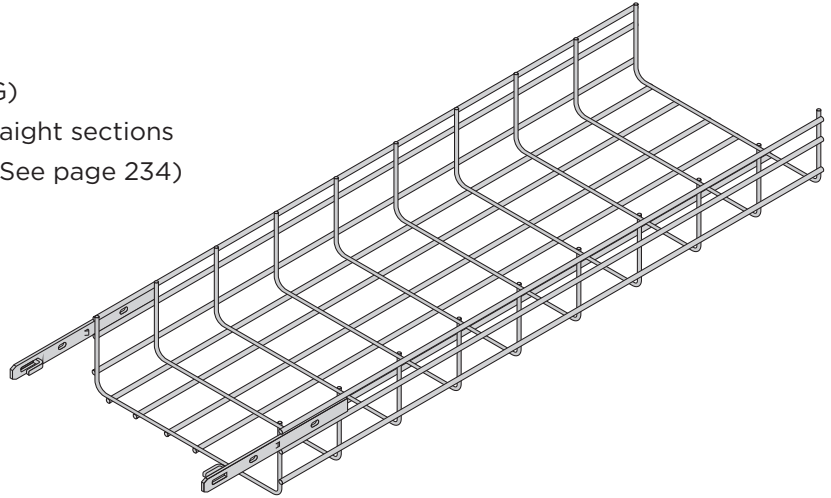

Approvals		Part Description	Width Nominal	Dimensions Wire Dia (in.)	Wt. (piece)	Loading (lb/ft)				
UL	cUL					5' Span	6' Span	8' Span	9' Span	
			CAT4-04SL-120	4" (100mm)	0.197	9.3	108	75	42	33
			CAT4-08SL-120	8" (200mm)	0.197	14.5	108	75	42	33
			CAT4-12SL-120	12" (300mm)	0.236	25.3	182	127	71	56
			CAT4-16SL-120	16" (400mm)	0.236	29.8	182	127	71	56
			CAT4-18SL-120	18" (450mm)	0.236	32.0	182	127	71	56
			CAT4-20SL-120	20" (500mm)	0.236	34.3	182	127	71	56
			CAT4-24SL-120	24" (600mm)	0.236	38.8	182	127	71	56

Load Values are determined by NEMA VE1 testing. Copies of load tests available upon request.

Safety Factor 1.5





WIRE BASKET SYSTEM

QUADRUPLE ROD REINFORCED TRAY (6" DEPTH)

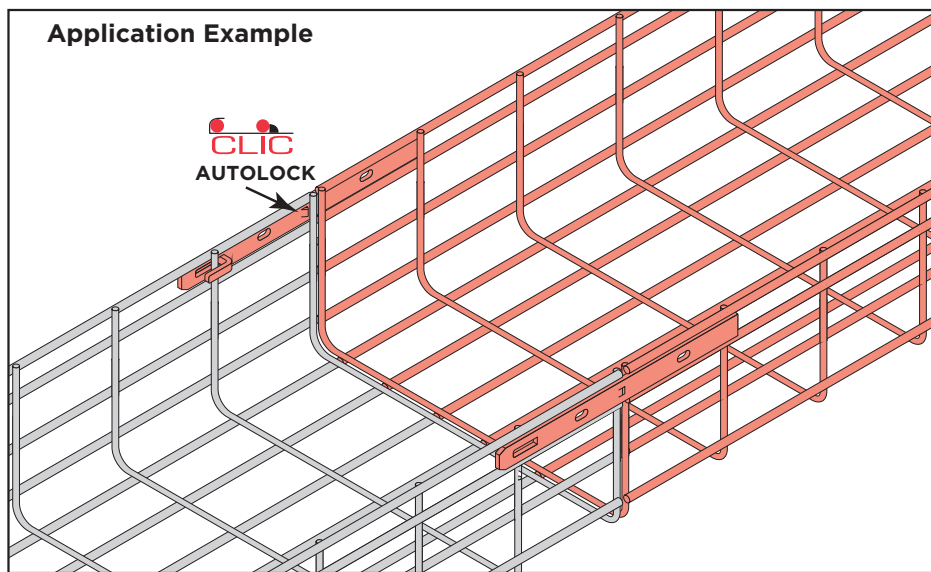
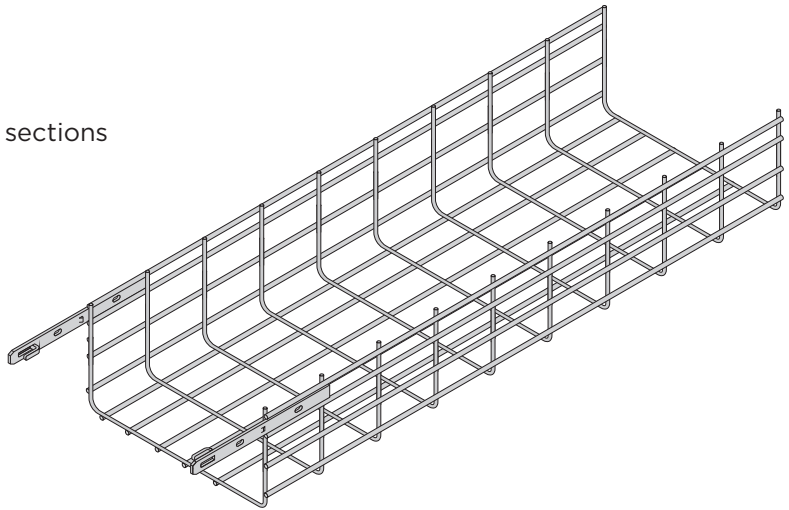
QUADRUPLE ROD REINFORCED TRAY (6" DEPTH) [CAT6-(W)SL-120]

- Quadruple rod reinforced tray is 6" high
- Standard length of tray is 10'
- Standard finish is electro-galvanized (EG)
- No hardware is necessary to connect straight sections
- For continuous grounding use CAT-GC (See page 234)

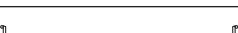

Part Description		Width Nominal	Dimensions Wire Dia (in.)	Wt. (piece)	Loading (lb/ft)			
					5' Span	6' Span	8' Span	9' Span
	CAT6-08SL-120	8" (200mm)	0.236	25.3	235	163	92	73
	CAT6-12SL-120	12" (300mm)	0.236	29.8	235	163	92	73
	CAT6-16SL-120	16" (400mm)	0.236	34.3	235	163	92	73
	CAT6-18SL-120	18" (450mm)	0.236	36.4	235	163	92	73
	CAT6-20SL-120	20" (500mm)	0.236	38.8	235	163	92	73
	CAT6-24SL-120	24" (600mm)	0.236	48.4	235	163	92	73

Load Values are determined by NEMA VE1 testing. Copies of load tests available upon request.

Safety Factor 1.5

SPLICE

Weight: .29/each

- Splice bar connector is $\frac{3}{4}$ x 9" long
- Standard finish is electro-galvanized (EG)
- Connect using CH3 (sold separately)
- Bend 90° for use as an angle connector

NOTES:

1. Always place nut on outside of tray
2. For use with CAT2, CAT4, & CAT6 tray
3. The splice connector is used to connect remnant sections of tray cut from standard lengths and to field fabricate fittings.

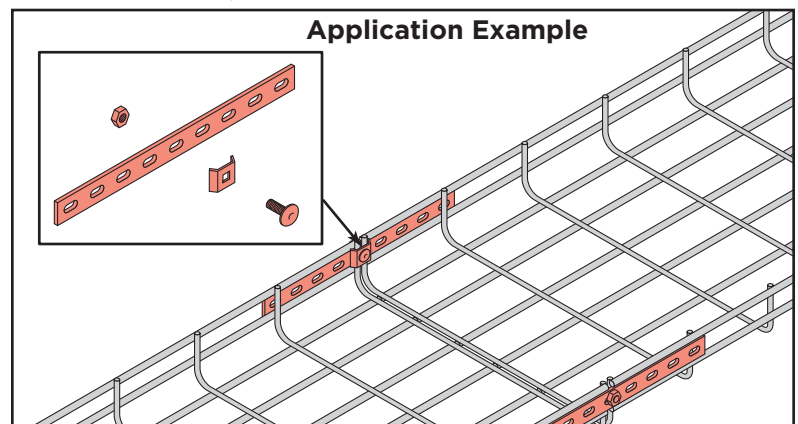
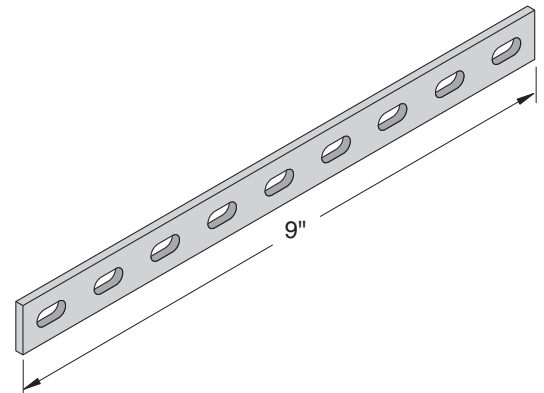

BEND & INTERSECTION BARS

T-BAR

Weight: 1.43/each

- T-Bar connector is $\frac{3}{4}$ x 44" long
- Connect using CH3 (sold separately)
- Bend 90° for use as an angle connector

T-BAR-22

Weight: .715/each

- T-Bar connector is $\frac{3}{4}$ x 22" long
- Connect using CH3 (sold separately)

NOTES:

1. Always place nut on outside of tray
2. For use with CAT2, CAT4, & CAT6 tray
3. Used for tees which require a heavier support
4. These bars are normally cut to appropriate length

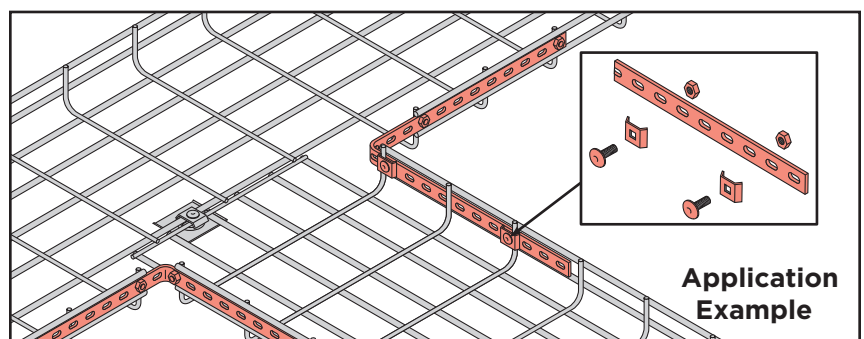
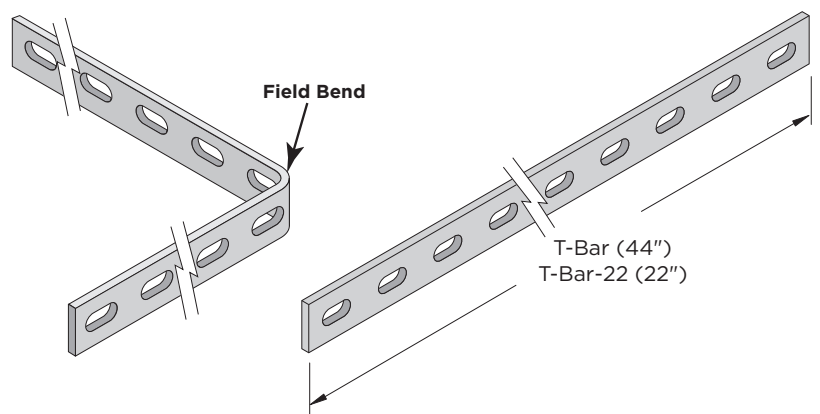

WIRE BASKET SYSTEM

CONNECTOR HARDWARE

CONNECTOR HARDWARE OVERVIEW

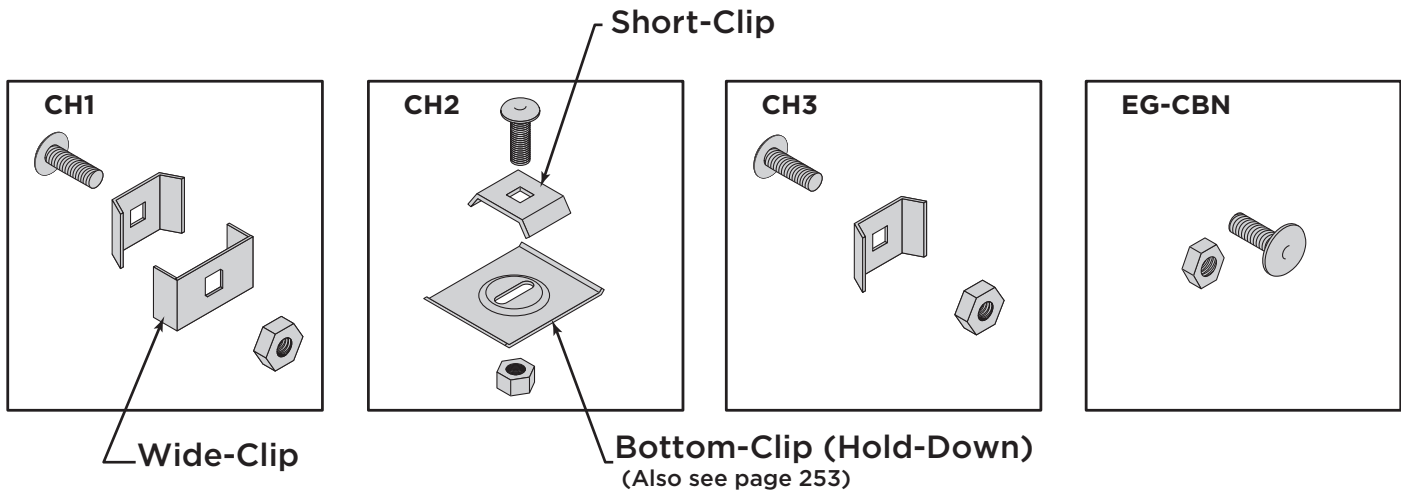

Part Kit	Weight	No./ Pkg
CH1	0.70	10
CH2	1.16	10
CH3	0.44	10
EG-CBN	0.20	10

Single Part	WEIGHT	NO./ PKG
Short-Clip	0.20	10
Wide-Clip	0.31	10
Bottom-Clip	0.92	10

CONNECTOR KIT [CH1]

- Standard bar connector is $1\frac{3}{16} \times 1\frac{1}{16}$ "
- Standard finish is electro-galvanized (EG)
- Sold in packs of 10
(EG-CBN connector hardware included)

NOTE: Always place nut on outside of tray

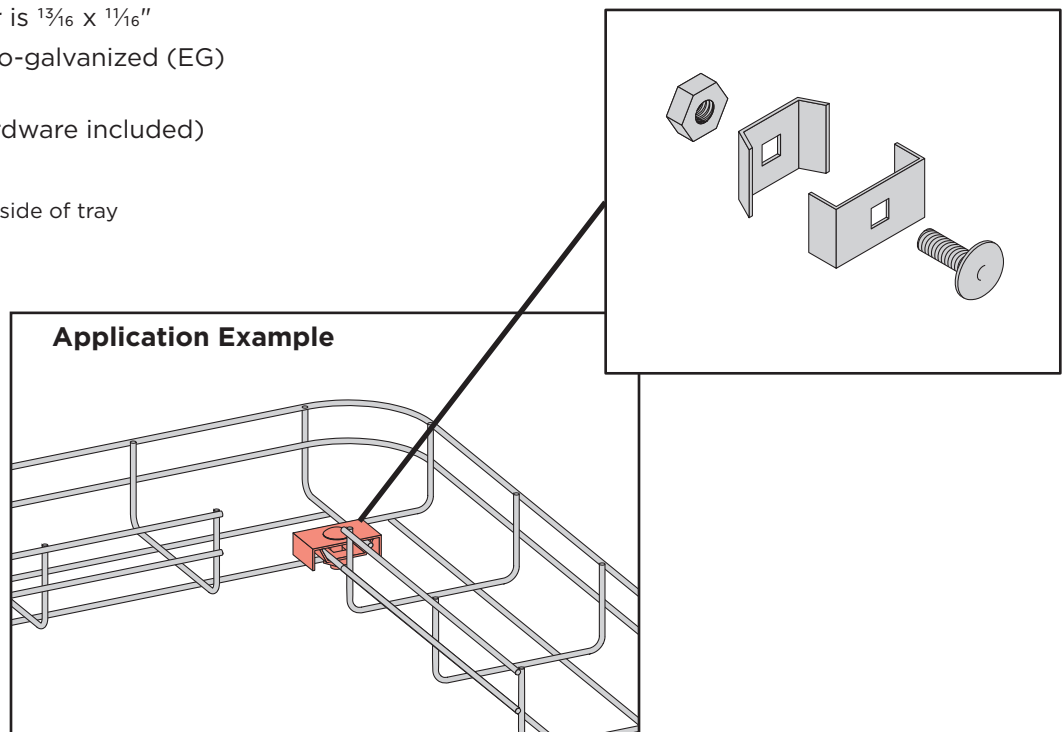

CONNECTOR HARDWARE KITS

CONNECTOR KIT [CH2]

- Bottom connector is 2 x 2³/₈"
- Standard finish is electro-galvanized (EG)
- Sold in packs of 10
(EG-CBN connector hardware included)

NOTE: Always place nut on outside of tray

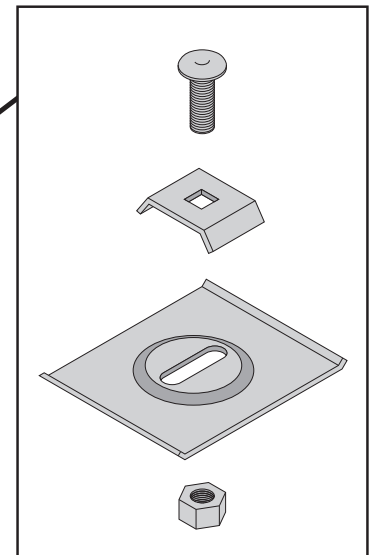
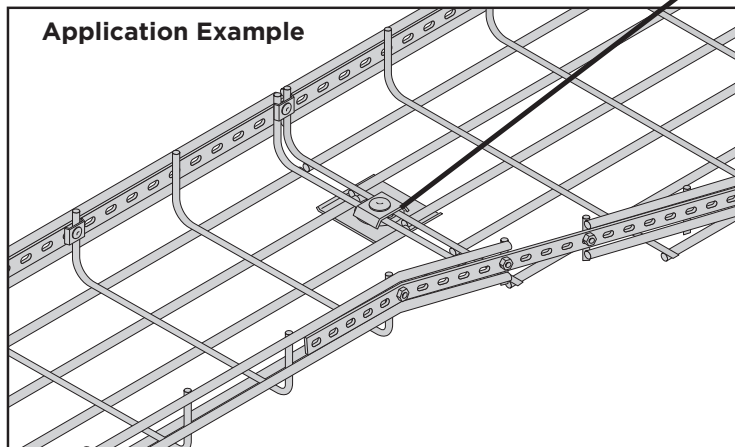

CONNECTOR KIT [CH3]

- Universal connector is 1¹/₁₆ x 1⁵/₁₆"
- Standard finish is electro-galvanized (EG)
- Sold in packs of 10
(EG-CBN connector hardware included)

NOTE: Always place nut on outside of tray

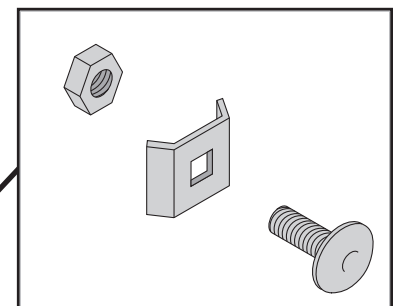
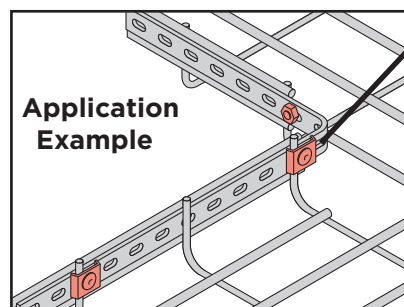

CONNECTOR HARDWARE [EG-CBN]

- 1/4-20 x 3/4" Carriage bolt
- 1/4-20 Hex head nut
- Standard finish is electro-galvanized (EG)
- Sold in packs of 10 each

NOTE: Always place nut on outside of tray

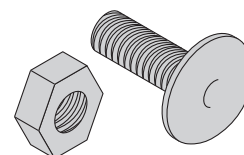

WIRE BASKET SYSTEM

U SUPPORT BRACKET [CAT-USB-120]

Weight: 6.83 lb/each

- U support bracket $1\frac{5}{16} \times 1\frac{5}{16}$ " channel
- Standard finish is pregalvanized (PG)
- Support is 10' long, customer cuts to size as needed
- Cut lengths 6" wider than tray width for trapeze
Cut lengths 1" shorter than tray width for single rod support
- Unique grip system requires only a push of a screwdriver to fasten the tray to the supports

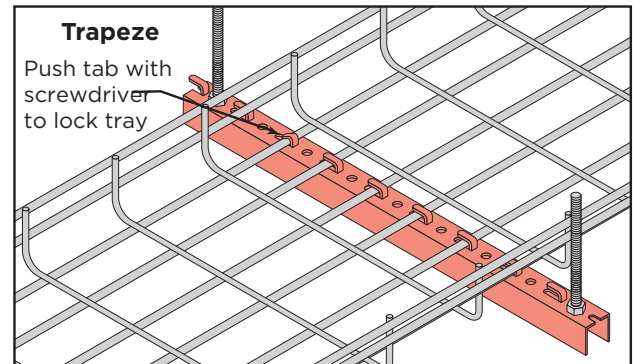
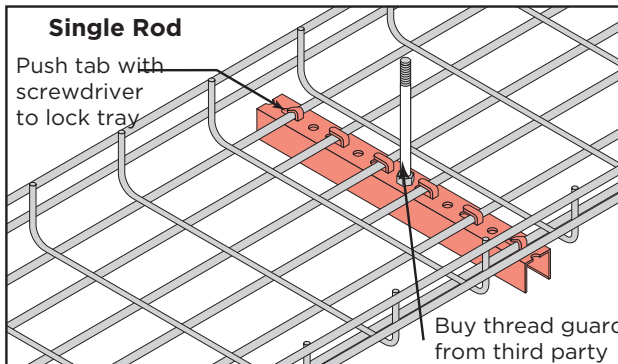
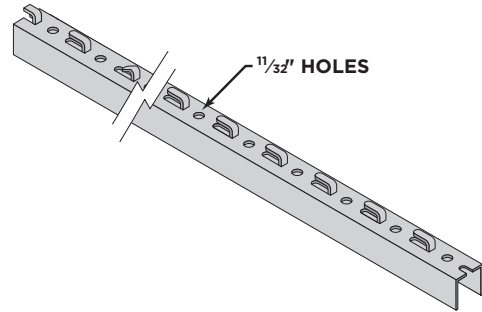

SUPPORT BRACKET MEDIUM [CAT-MSB-120] & HEAVY [CAT-HSB-120]

- Heavy support bracket is $1\frac{5}{8} \times 1\frac{5}{8}$ " strut, Medium support bracket is $1\frac{5}{8} \times 1\frac{3}{16}$ " strut
- Standard finish is pregalvanized (PG)
- Support is 10' long, customer cuts to size as needed
- Cut lengths 6" wider than tray width for trapeze
Cut lengths 1" shorter than tray width for single rod support
- Unique grip system requires only a push of a screwdriver to fasten the tray to the supports

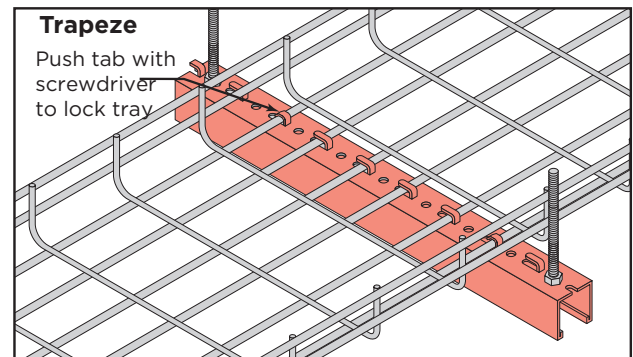
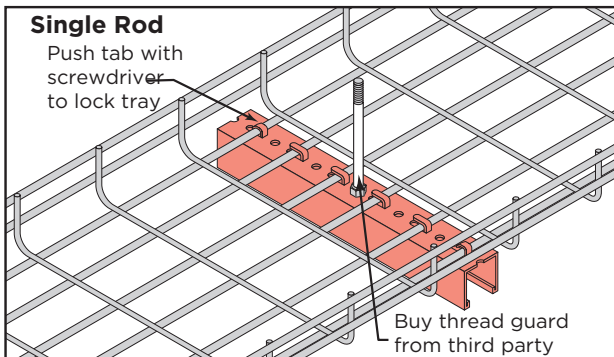
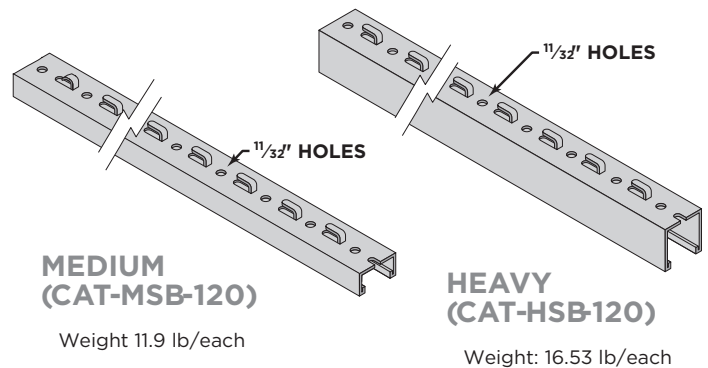

DROP ROD CLIP [CAT-SIDE-HC]

Weight: .13 lb/each

- Standard finish pregalvanized (PG)
- .08" Bracket thickness
- For all widths of tray

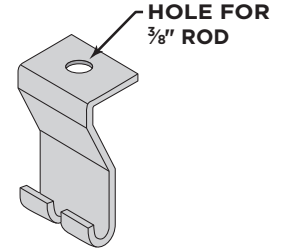
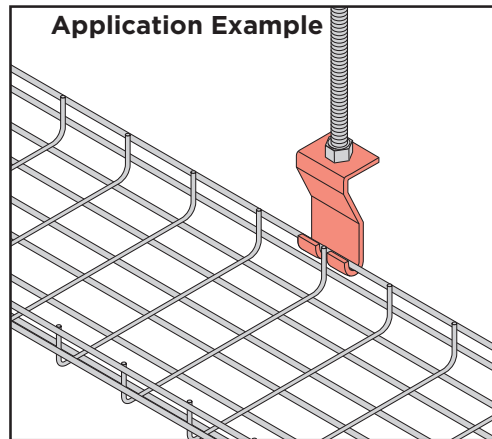

DROP ROD CLIP [CAT-1X6-HC]

Weight: .12 lb/each

- Standard finish pregalvanized (PG)
- .08" Bracket thickness
- For all 4"w & 6"w tray

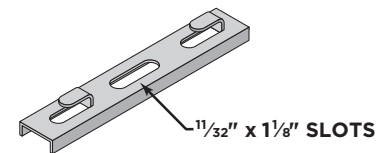
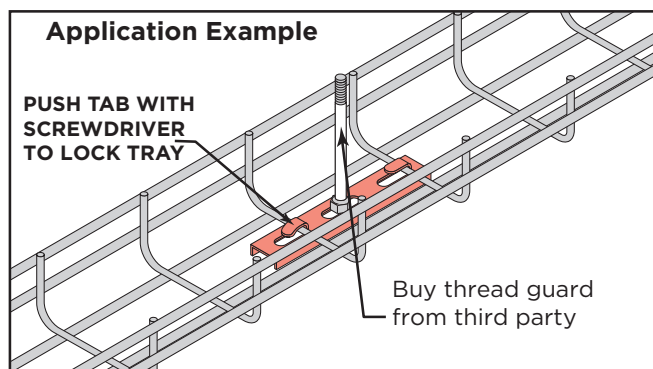

DROP ROD CLIP [CAT-2X8-HC]

Weight: .40 lb/each

- Standard finish pregalvanized (PG)
- .08" Bracket thickness
- For all 8" w & 12" w tray

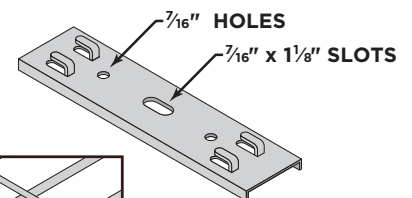
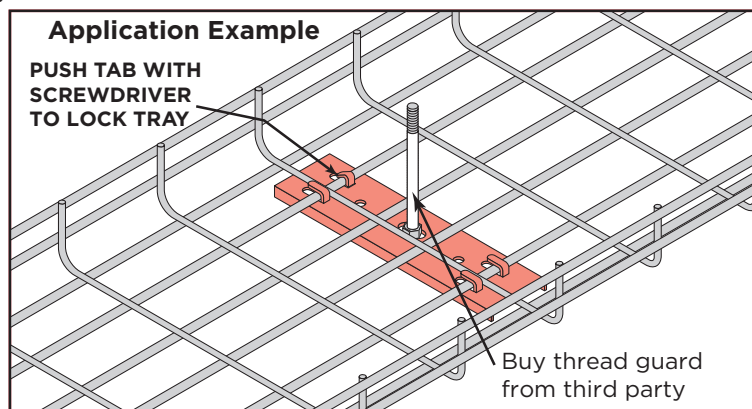

WIRE BASKET SYSTEM

WALL & CEILING MOUNTS

CEILING CLIP [CAT-CCA-(W)]

- For attaching tray to ceiling
- Standard finish pregalvanized (PG)
- Easy mounting of the cable tray using grips and autolock

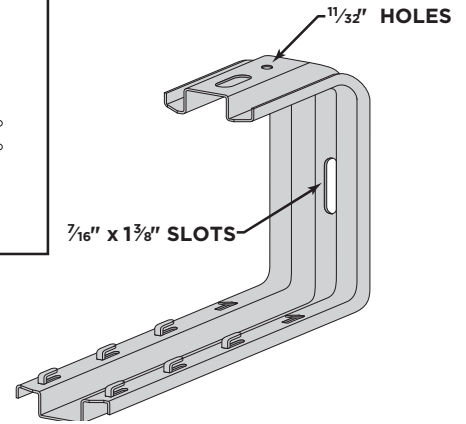
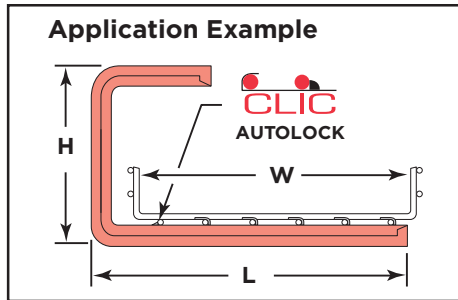

Ceiling Clip [CAT-CCA-(W)]

Part No.	Tray Size(W)	Height(H)	Length(L)	Wt(Lbs)	Load(Lbs)
CAT-CCA-04	4"	7"	6"	1.3	270
CAT-CCA-06	6"	7"	8"	1.5	225
CAT-CCA-08	8"	7"	10"	1.7	202
CAT-CCA-12	12"	7"	14"	2	180
CAT-CCA-16	16"	7"	18"	2.3	90

WALL CLIP [CAT-CPA-(W)]

- For attaching tray to wall
- Standard finish pregalvanized (PG)
- Easy mounting of the cable tray using grips and autolock

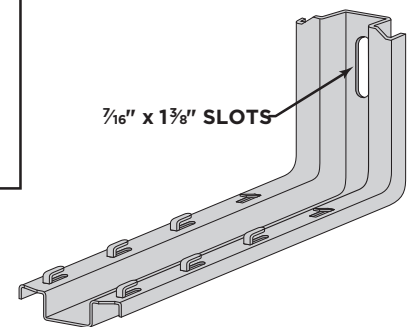
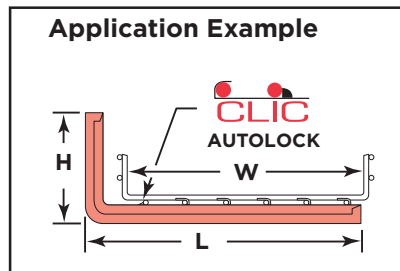

Wall Clip [CAT-CPA-(W)]

Part No.	Tray Size(W)	Height(H)	Length(L)	Wt(Lbs)	Load(Lbs)
CAT-CPA-06	6"	5"	8"	1	337
CAT-CPA-08	8"	5"	10"	1.1	225
CAT-CPA-12	12"	5"	14"	1.5	202
CAT-CPA-16	16"	5"	18"	1.8	90

PENDANT [CAT-PPA-(H)]

- Standard finish is pregalvanized (PG)
- For attaching tray to ceiling.
Used with wall clip CAT-CPA Series

Pendant [CAT-PPA-(H)]			
Part No.	Height(H)	Length(L)	Wt(Lbs)
CAT-PPA-06	6"	5"	0.7
CAT-PPA-10	10"	5"	1.1
CAT-PPA-14	14"	5"	1.3
CAT-PPA-18	18"	5"	1.7
CAT-PPA-22	22"	5"	2.0
CAT-PPA-26	26"	5"	2.3

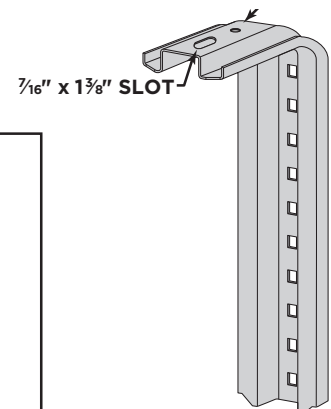
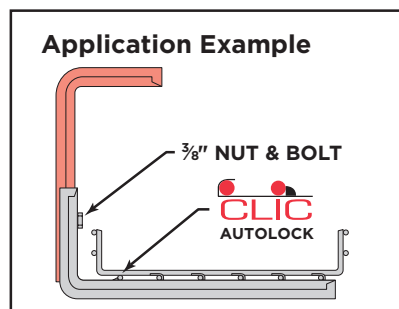

CANTILEVER & ZED BRACKETS

ZED [CAT-ZBAR-120]

Weight: 11.24 lb/each 1/4" x 1 3/8" SLOTS

- ZED floor or wall mounted support is 1/2 x 3 1/2
- Standard finish pregalvanized (PG)
- Support is 10' long, customer cuts to size as needed
- Unique grip system requires only a push of a screwdriver to fasten the tray to the supports

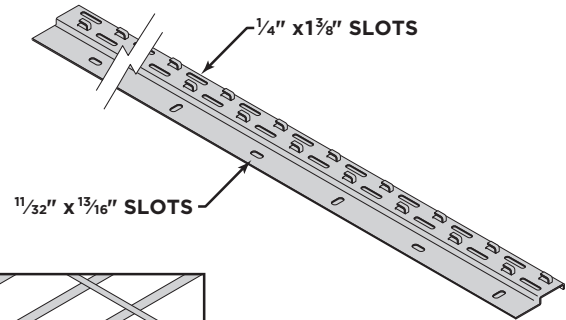

Application Example

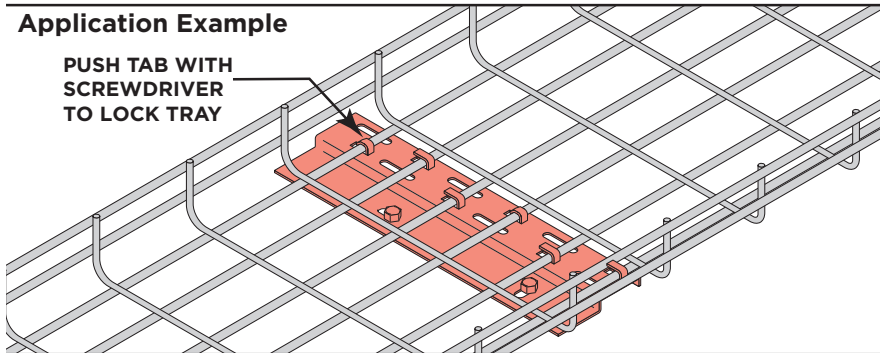

CANTILEVER MEDIUM [CAT-MWSB-(W)] & HEAVY [CAT-HWSB-(W)]

- Standard finish is hot-dipped galvanized (HG)
- Cantilever arm support 1 5/8 x 1 5/8" or 1 5/8 x 1 3/16" strut
- Unique Auto-Lock system requires no hardware to fasten the tray to the supports
- Use Strut Profile to support other items below the support bracket using strut hardware

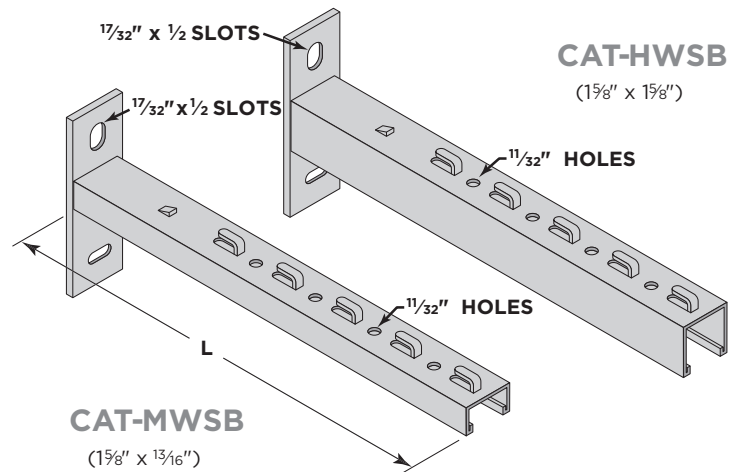

Cantilever Medium [CAT-MWSB-(W)] & HEAVY [CAT-HWSB-(W)]					
Part No.	Channel Size	Tray Width (W)	Length (L)	Wt (Lbs)	Load (Lbs)
CAT-MWSB-06	1 5/8" x 1 3/16"	6"	8"	1.3	270
CAT-MWSB-08	1 5/8" x 1 3/16"	8"	10"	1.5	225
CAT-MWSB-12	1 5/8" x 1 3/16"	12"	14"	1.9	157
CAT-HWSB-08	1 5/8" x 1 5/8"	8"	10"	1.9	562
CAT-HWSB-12	1 5/8" x 1 5/8"	12"	14"	2.5	450
CAT-HWSB-18	1 5/8" x 1 5/8"	18"	18"	3	337
CAT-HWSB-20	1 5/8" x 1 5/8"	20"	22"	3.6	292
CAT-HWSB-24	1 5/8" x 1 5/8"	24"	26"	4.1	247

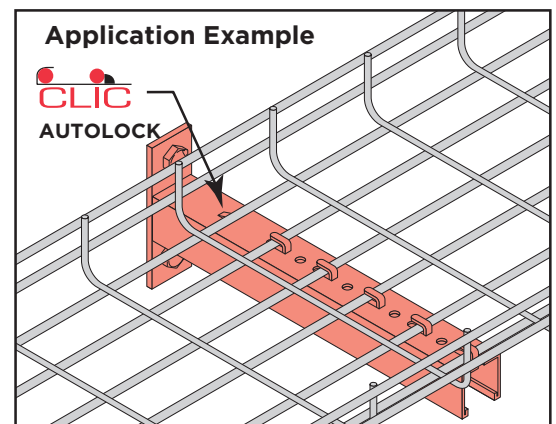

WIRE BASKET SYSTEM

HANGERS

HANGER [CAT-HGR-2]

- Standard finish is pregalvanized (PG)
- Ceiling or center hung with threaded rod

NOTE: For use with CAT2-02 only

Application Example

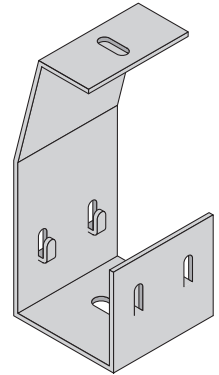
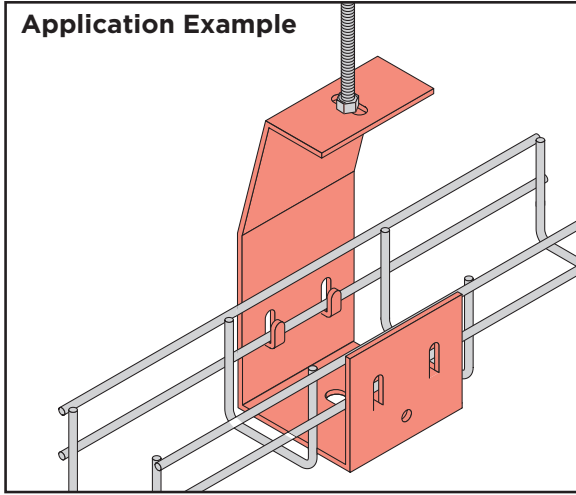

HANGER [CAT-HGR-4]

- Standard finish is pregalvanized (PG)
- Ceiling or center hung with threaded rod

NOTE: For use with CAT2-02 only

Application Example

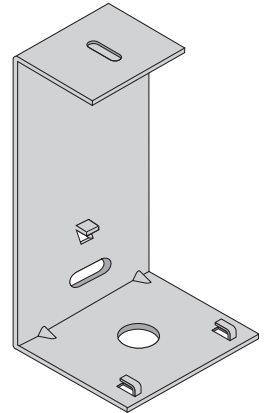
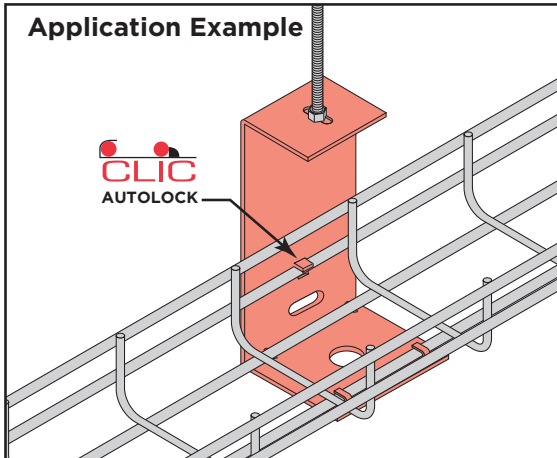

WALL BRACKET [CAT-WC-2]

- Standard finish is pregalvanized (PG)

NOTE: For use with CAT2-02 only

Application Example

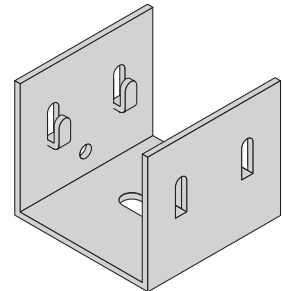
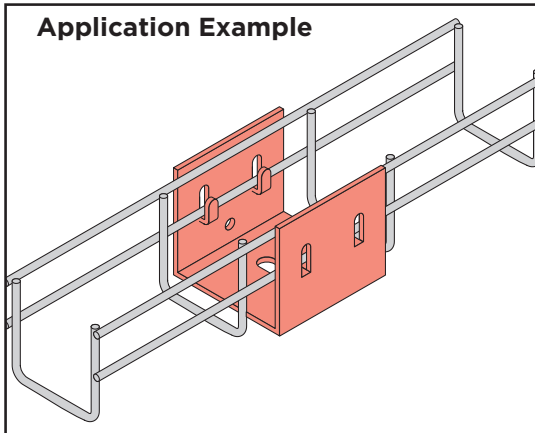

HANGING BRACKET & PENDENTS

SINGLE CHANNEL PENDANT [PS 651-(L)]

- Standard finish is electro-galvanized (EG)

Single Channel Pendant [PS 651-(L)]			
Part No.	Length(L)	Uniform Load	Weight"
PS651-06	6"	1,200	1.85
PS651-12	12"	600	2.93
PS651-18	18"	400	4.01
PS651-24	24"	300	5.09

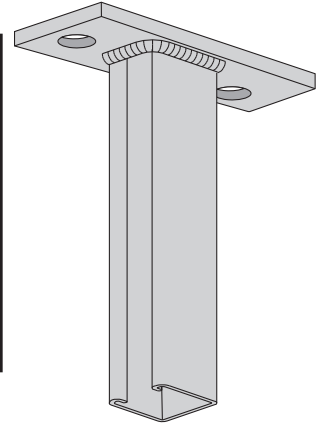
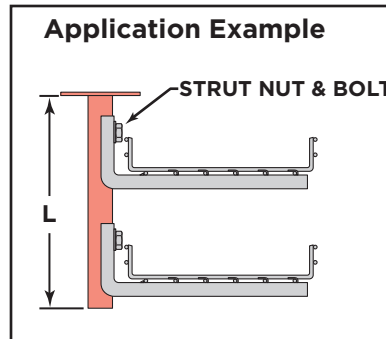

BACK-TO-BACK CHANNEL PENDANT [PS 809-(L)]

- Standard finish is electro-galvanized (EG)

Back-to-Back Channel Pendant [PS 809-(L)]			
Part No.	Length(L)	Uniform Load	Weight
PS809-12	12"	2,000	5.02
PS809-18	18"	1,300	6.92
PS809-24	24"	1,000	8.82
PS809-30	30"	800	10.72
PS809-36	36"	650	12.62

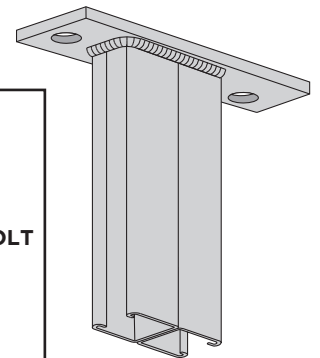
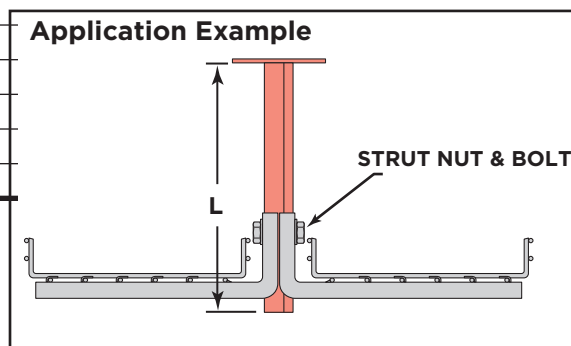

HANGING BRACKET [CAT-CB-USB]

Weight: .8 lb/each

- Standard finish is pregalvanized (PG)
- For Use with CAT-USB-120 Style Support Bracket Channel

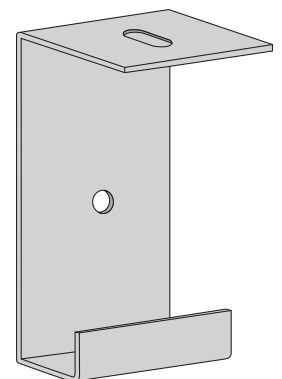
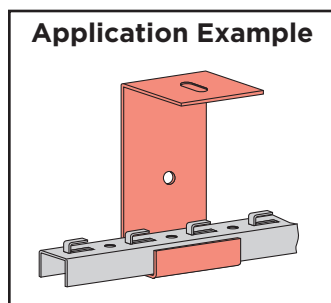
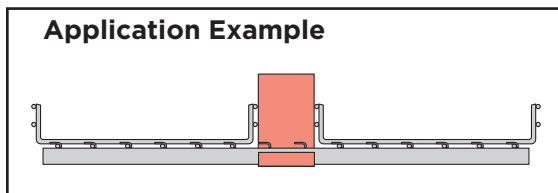

WIRE BASKET SYSTEM

HANGING BRACKETS

HANGING BRACKET [CAT-AB-USB]

Weight: .53 lb/each

- Standard finish is pregalvanized (PG)
- For use with CAT-USB-120 Support Bracket Channel

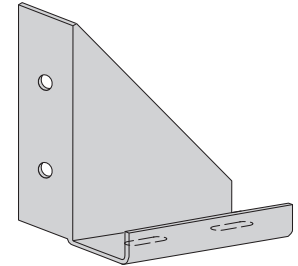
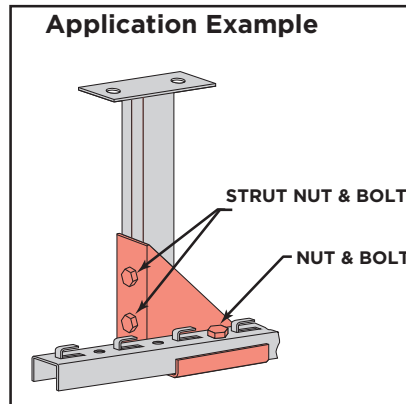
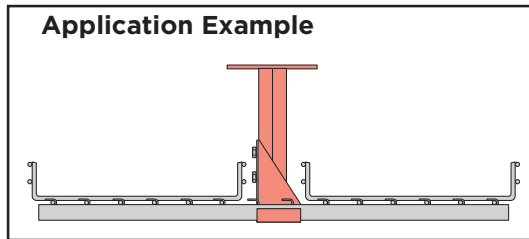

HANGING BRACKET [CAT-AB-HSB]

Weight: .62 lb/each

- Standard finish is hot-dipped galvanized (HG)
- For Use with:
CAT-MSB-10 Medium Support Bracket Strut
CAT-HSB-10 Heavy Support Bracket Strut

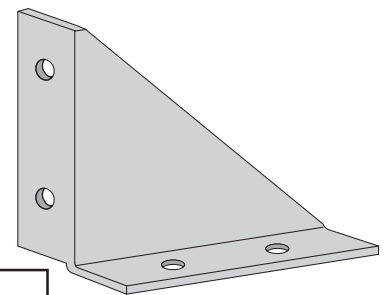
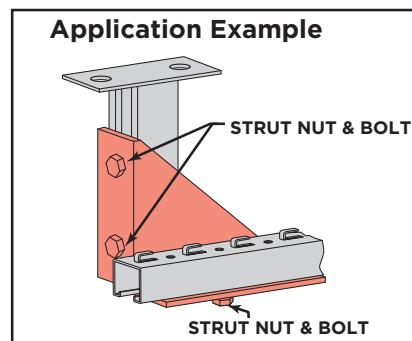
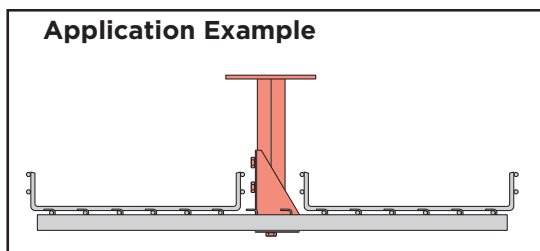

HANGING BRACKET [CAT-CB-MSB]

Weight: 1.46 lb/each

- Standard finish is pregalvanized (PG)
- For Use with:
CAT-MSB-10 Medium Support Bracket Strut

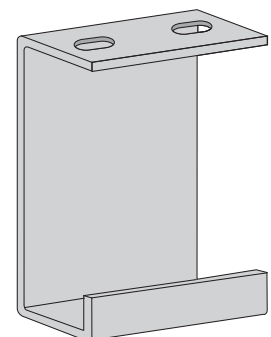
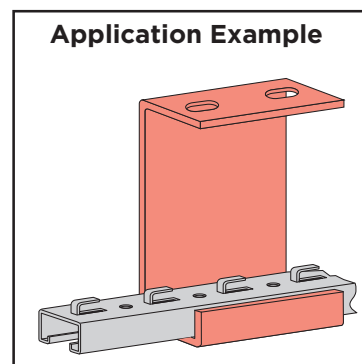
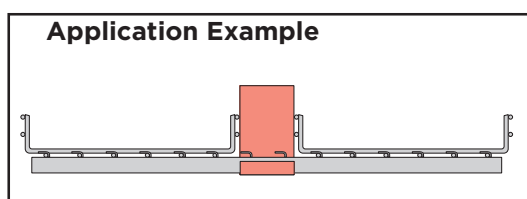

HANGING BRACKETS

HANGING BRACKET [CAT-CB-HSB]

Weight: 2.98 lb/each

- Available in pregalvanized (PG) or hot-dipped galvanized (HG)
- For Use with:
CAT-MSB-10 Medium Support Bracket Strut
CAT-HSB-10 Heavy Support Bracket Strut

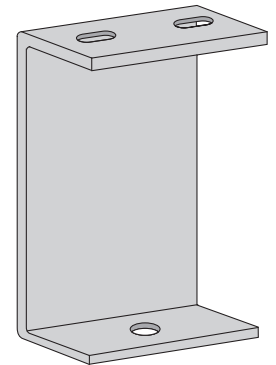
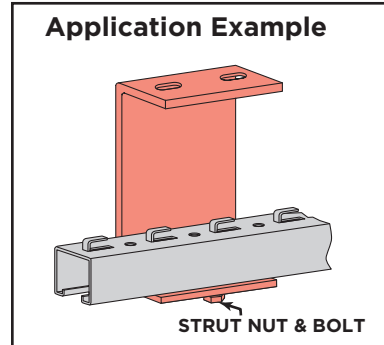
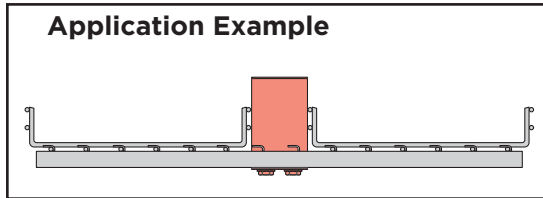

BRACKET [CAT-CMA-(W)]

- Standard finish is pregalvanized (PG)
- Mounted on cantilever arms or channels
- Easy mounting of the bracket using grips and autolock
- Designed for use with new/existing 158" strut framing

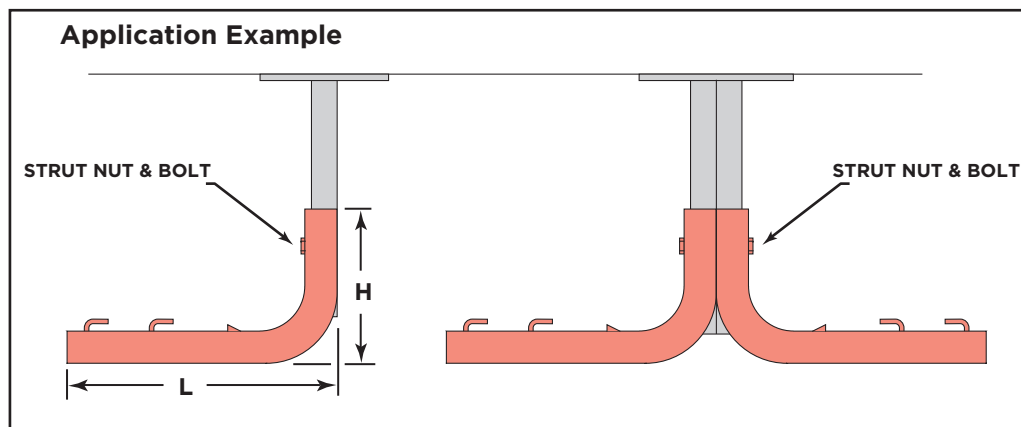
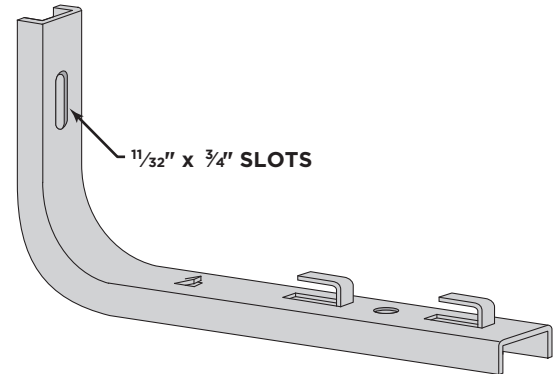

Bracket [CAT-CMA-(W)]

Part No.	Tray Width (W)	Height (H)	Length (L)	Wt (Lbs)	Load (Lbs)
CAT-CMA-04	4"	4.7"	5"	0.8	360
CAT-CMA-06	6"	4.7"	7"	1.0	270
CAT-CMA-08	8"	4.7"	9"	1.1	180
CAT-CMA-12	12"	4.7"	13"	1.5	135

WIRE BASKET SYSTEM

PEDESTAL BRACKETS

PEDESTAL BRACKETS [CAT-PED-06] & [CAT-PED-12]

- Channel use on pedestal for raised floor
- Attach to pedestal using U-Bolt & nuts (included)

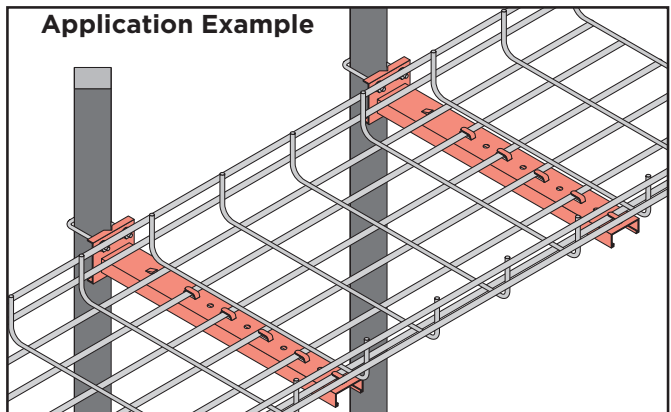
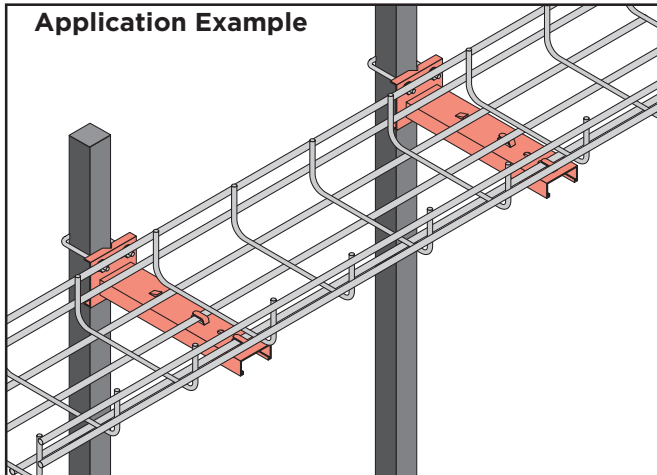
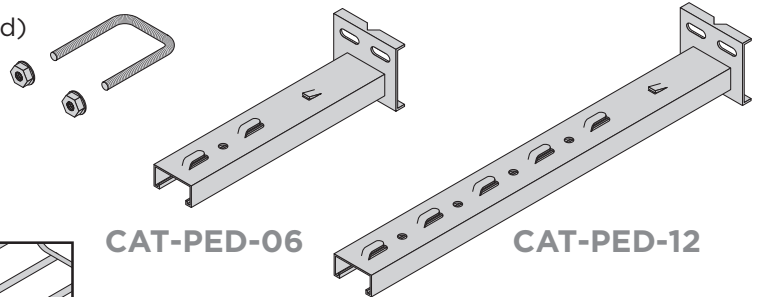

PEDESTAL KIT [CAT-PED-KIT]

- Channel use on pedestal for raised floor
- Attach to pedestal using U-Bolt & nuts (included)

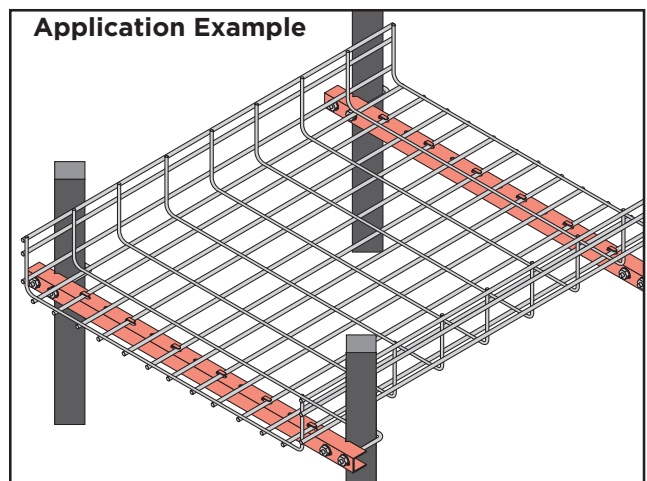
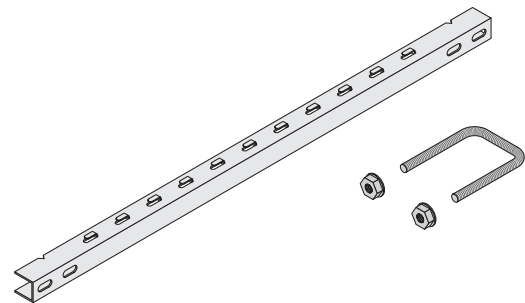
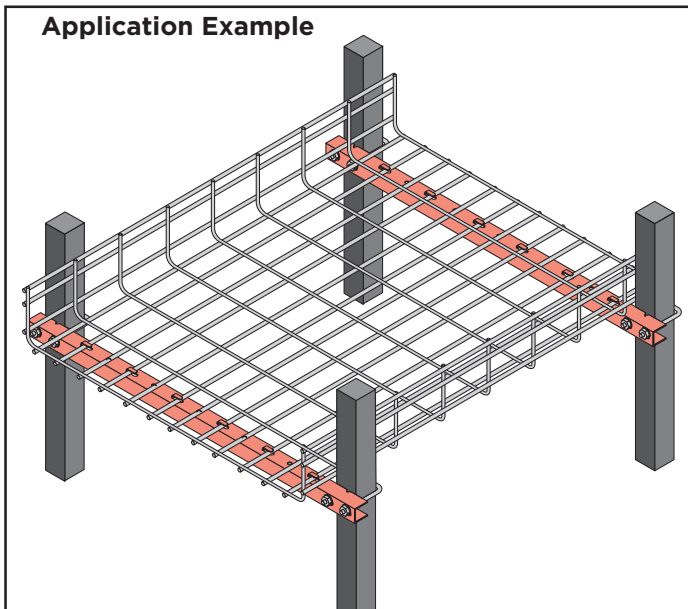

COVER [CAT-CVR-(W)]

- Standard finish is pregalvanized (PG)
- Length is 10'

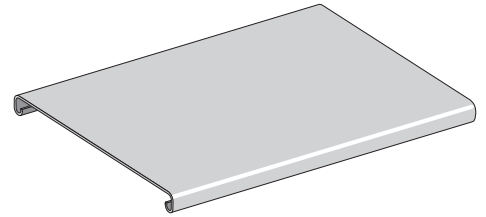

Part	WEIGHT (lb)
CAT-CVR-02	5.29
CAT-CVR-04	7.93
CAT-CVR-06	10.58
CAT-CVR-08	13.22
CAT-CVR-12	18.52
CAT-CVR-16	35.71"
CAT-CVR-18	39.68
CAT-CVR-20	43.65
CAT-CVR-24	51.53

Application Example

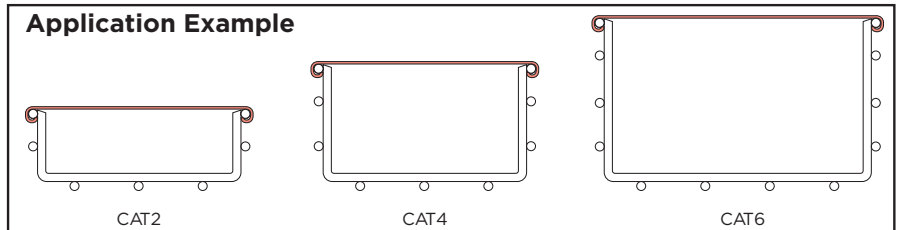

TRAY DIVIDERS [CAT2-01SB-120], [CAT4-01SB-120], & [CAT6-01SB-120]

- Standard finish is pregalvanized (PG)
- Locks into tray with auto-lock tabs (no hardware required)
- Cut "V" notches into bottom flange to make barriers for flat fittings

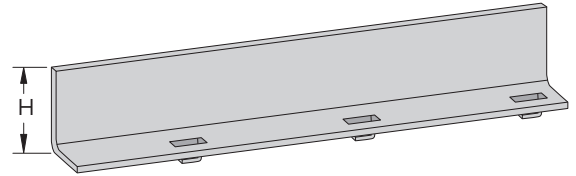

Application Example

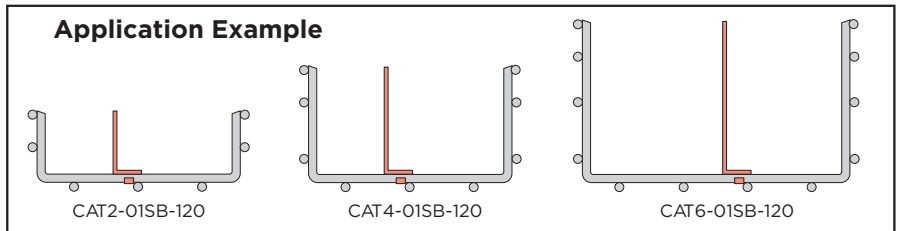

DROP OUT [CAT-(W)DO]

- Standard finish is pregalvanized (PG)
- CAT-UNI-DO can be used in any 2" x 4" mesh opening or as a "side-out"

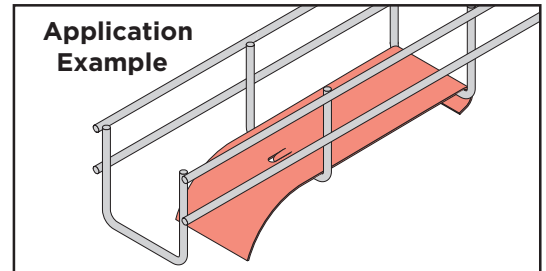
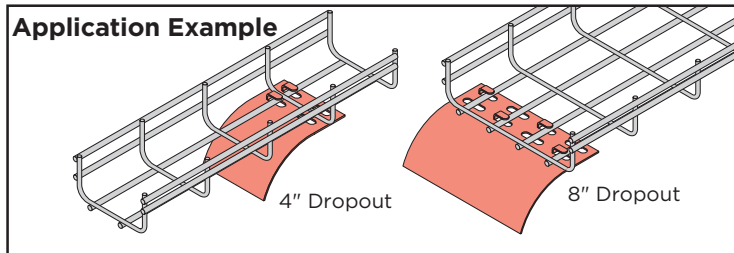
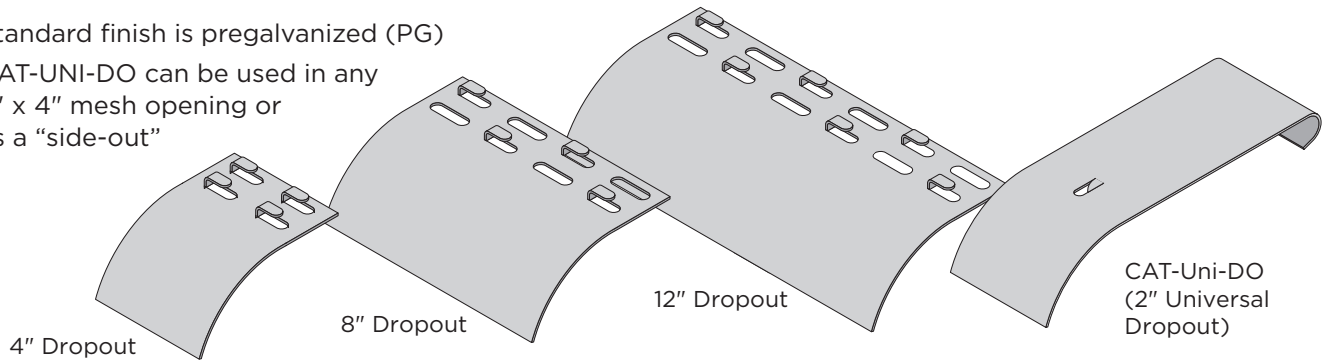

WIRE BASKET SYSTEM

ACCESSORIES

BLIND END [CAT(H)-(W)BE]

- Standard finish is pregalvanized (PG)
- Standard use per blind end is:
(2 pc) CH3 (sold separately)

NOTES:

1. Always place nut on outside of tray

Part	WEIGHT (lb)
CAT2-04BE	0.18
CAT2-06BE	0.22
CAT2-08BE	0.28
CAT2-12BE	0.40
CAT2-16BE	0.50
CAT2-18BE	0.57
CAT2-20BE	0.64
CAT2-24BE	0.70

Part	WEIGHT (lb)
CAT4-04BE	0.52
CAT4-08BE	0.64
CAT4-12BE	0.76
CAT4-16BE	0.96
CAT4-18BE	1.08
CAT4-20BE	1.20
CAT4-24BE	1.44

Part	WEIGHT (lb)
CAT6-08BE	0.82
CAT6-12BE	1.12
CAT6-16BE	1.42
CAT6-18BE	1.57
CAT6-20BE	1.72
CAT6-24BE	2.10

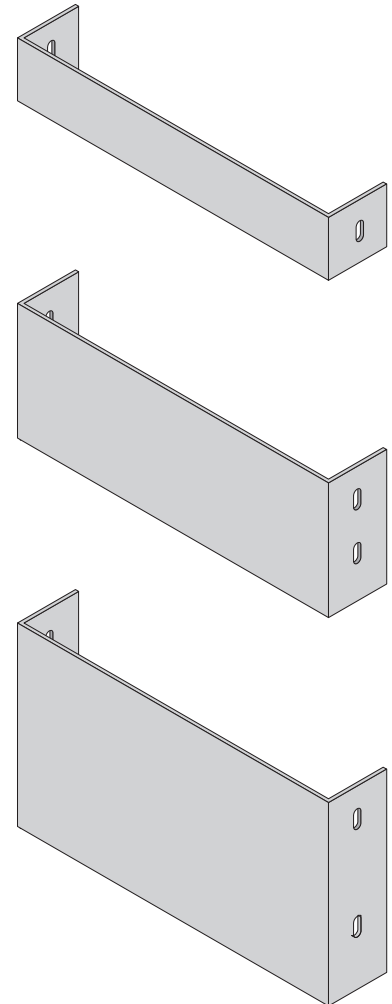
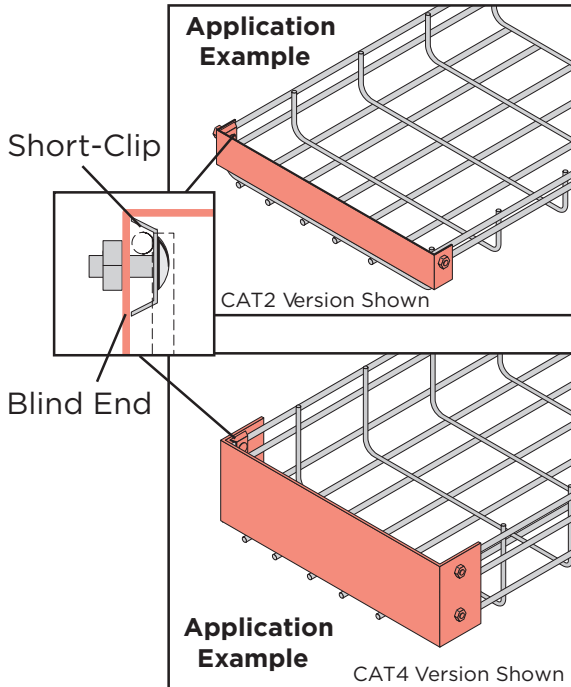

BOX CONNECTOR [CAT(H)-(W)CB]

- Standard finish is pregalvanized (PG)
- Standard use per box connector is:
(2 pc) CH3
(5 pc) EG-CBN
(both sold separately)

NOTES:

1. Always place nut on outside of tray
2. For use with CAT2, CAT4 & CAT6 tray only

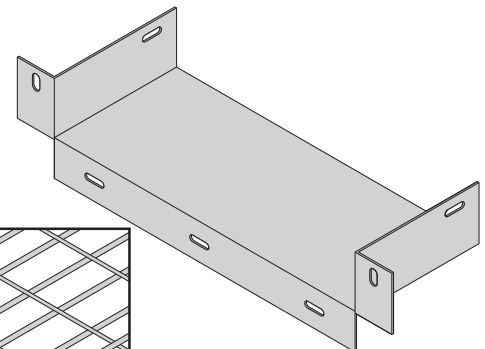
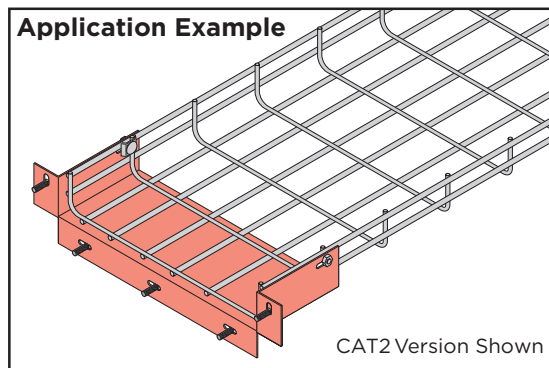

LIGHTING BRACKET [CAT-HLT]

- Standard finish is pregalvanized (PG)

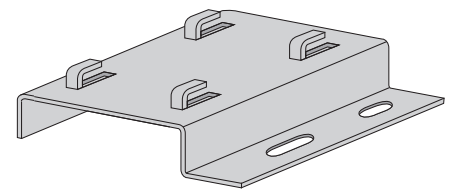
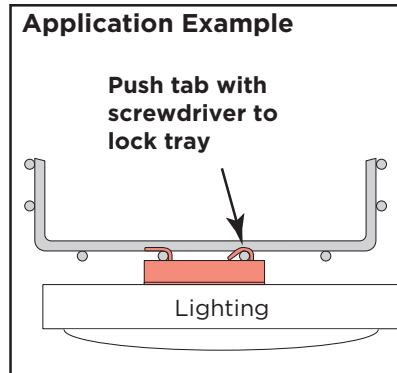

ELECTRICAL BOX BRACKET [CAT-EBC]

- Standard finish is pregalvanized (PG)

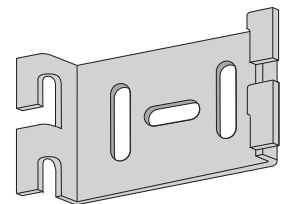
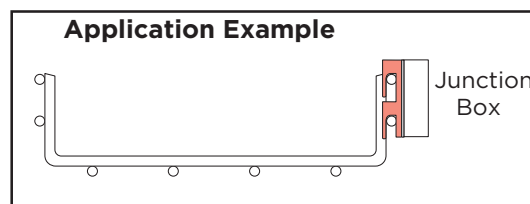

WALL SLEEVE [CAT(H)-(W)WS]

- Standard finish is pregalvanized (PG)
- Standard use per wall sleeve is:
 - (4 pc) CH3 (5 pc) 6112-0
 - (4 pc) 5003-1 (4 pc) 5009-1
 - (8 pc) EM -CC
 - (all sold separately)

NOTES:

1. Always place nut on outside of tray
2. Example CAT2-12WS

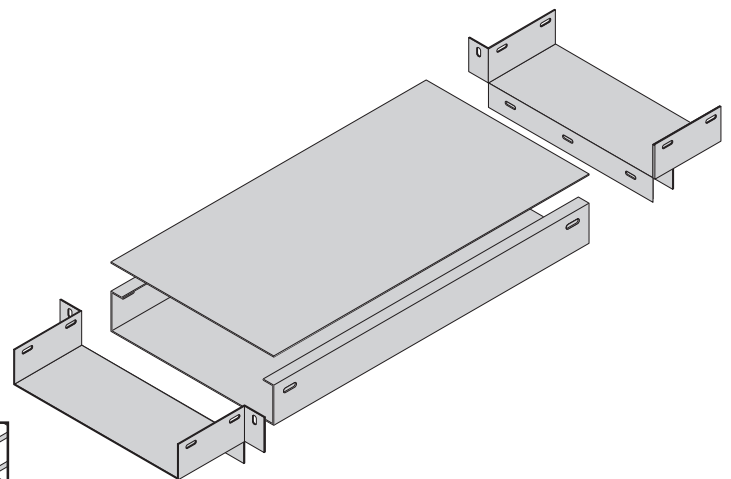
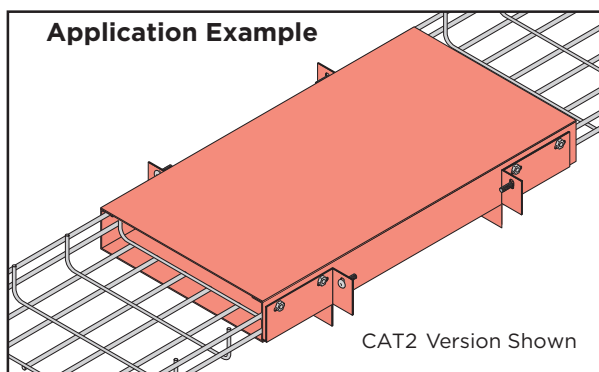

WIRE BASKET SYSTEM

FITTINGS OVERVIEW

FITTINGS OVERVIEW

Fittings are typically fabricated on the job. However, prefabricated fittings are available upon request. Please contact factory.

To determine the fitting hardware required to create a set of fittings, please consult our online calculator. [Choose Wire basket tray from the Products menu on the front page of www.copecabletray.com.]

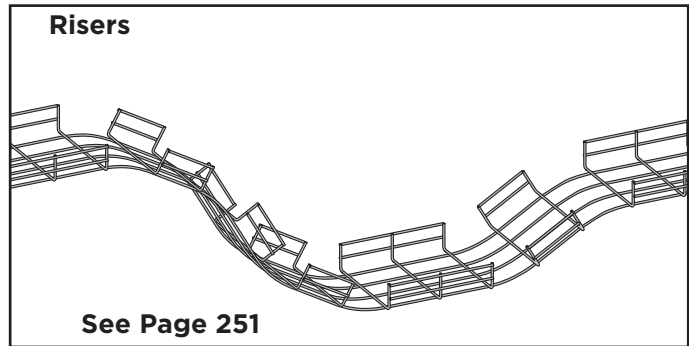
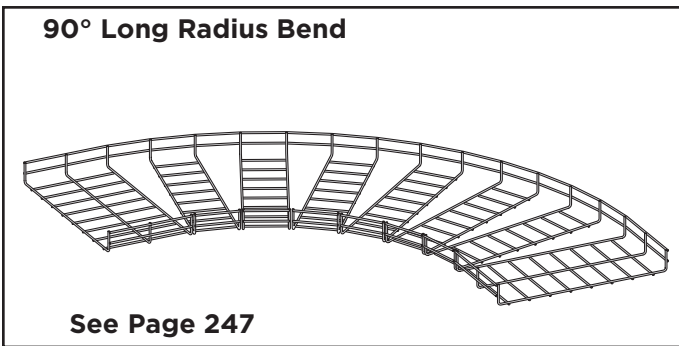
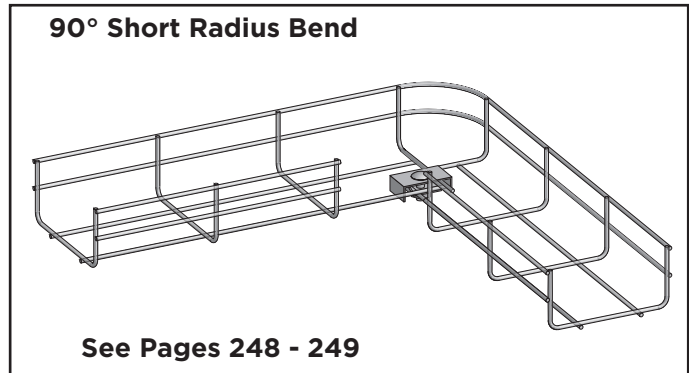
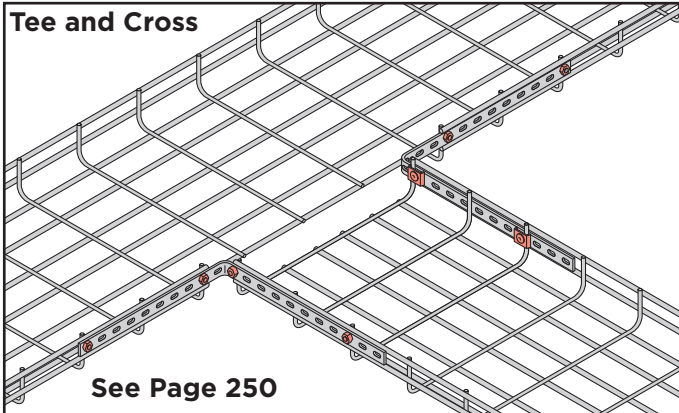

CUTTING TOOL [CAT-CUT]

Fittings can be formed easily on-site by cutting the bottom and side wires. Cut the tray bars on an angle as shown in the illustration.

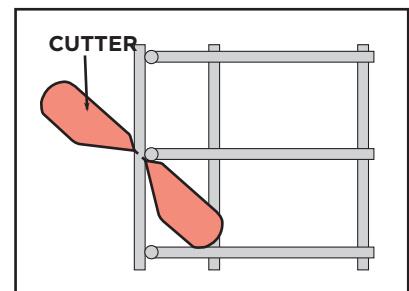
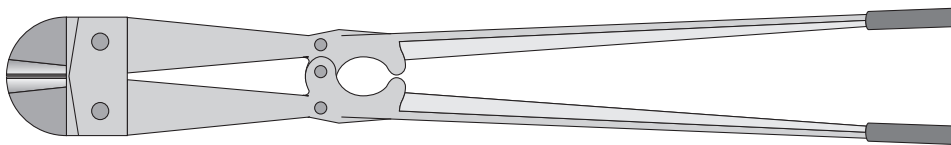

NOTE: When cutting, keep the remaining sharp edge away from the inside of the tray.

1 CUT THE BOTTOM AND SIDE WIRES

To form 90° bends in the tray, cut out the number of sections shown below based on the width of the tray used

2 ASSEMBLE USING APPROPRIATE HARDWARE

- Standard hardware is shown with each bend size.

Advantages:

- Use as bonding jumper
- Vertical support of standing sections
- Adjustable radius allowances

NOTE: Always place nut on outside of tray

Cut Out 4 Sections of Mesh as Shown	<p>(1) T-Bar (5 pcs) CH3</p>	<p>CAT2-04 16" Inside Radius</p> <p>CAT2-06 12" Inside Radius</p> <p>CAT2-08 12" Inside Radius</p>
Cut Out 6 Sections of Mesh as Shown	<p>(1) T-Bar (7 pcs) CH3</p>	<p>CAT2-12 17" Inside Radius</p>
Cut Out 7 Sections of Mesh as Shown	<p>(1) T-Bar (8 pcs) CH3</p>	<p>CAT2-16 18" Inside Radius</p> <p>CAT2-18 18" Inside Radius</p>
Cut Out 9 Sections of Mesh as Shown	<p>(1) T-Bar (10 pcs) CH3</p>	<p>CAT2-20 24" Inside Radius</p> <p>CAT2-24 24" Inside Radius</p>

WIRE BASKET SYSTEM

90° SHORT RADIUS BENDS

90° BENDS - FORMING INSTRUCTIONS

To form 90° bends in the tray, cut the wires shown in the color shaded area of the drawing which corresponds to the width of the tray used.

1 CUT THE BOTTOM AND SIDE WIRES

Bends can be formed easily on-site by cutting the bottom and side wires. The shaded areas indicated should be cut and removed. Then, simply bend Wire basket tray cable tray to form a 90° angle and you are ready to install. Make sure you use the appropriate hardware.

2 ASSEMBLE USING APPROPRIATE HARDWARE

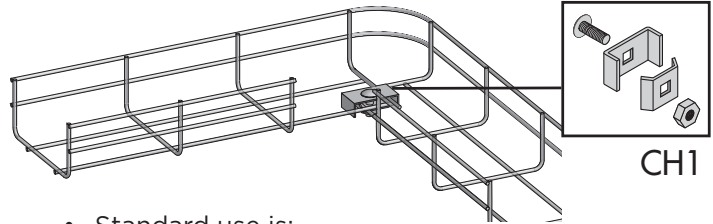

- Standard use is:
Sizes 4" - 12" (1 pc) CH1
Sizes 16" - 24" (2 pc) CH1

NOTE: Always place nut on outside of tray)

90° BENDS - CUTTING DIAGRAMS

4" (100mm)

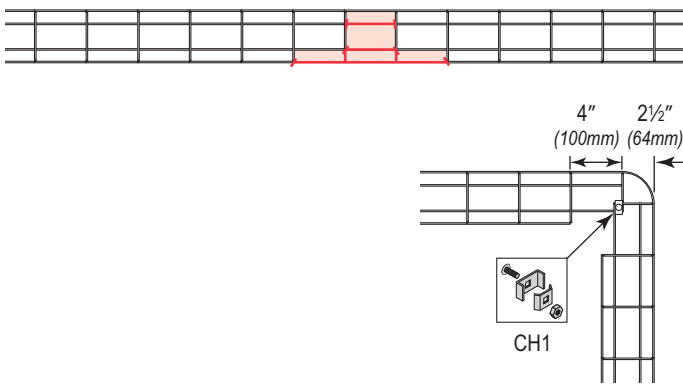

6" (150mm)

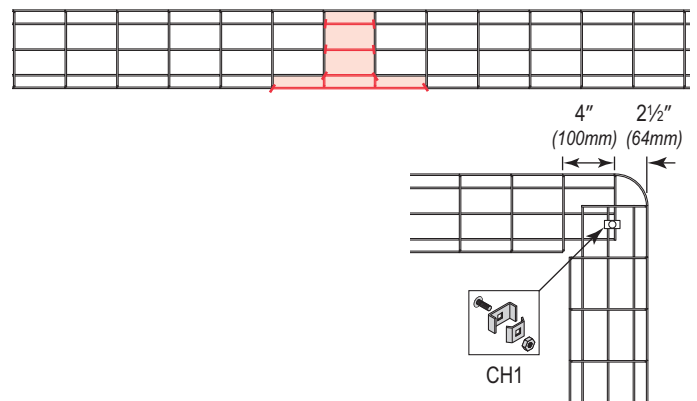

8" (200mm)

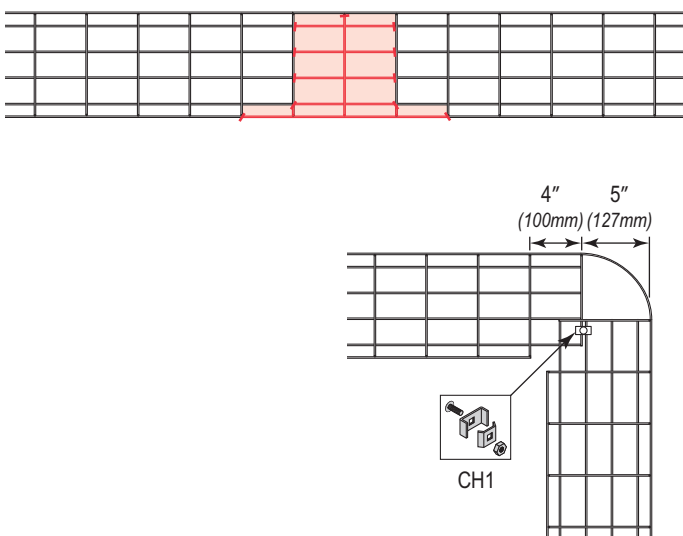

12" (300mm)

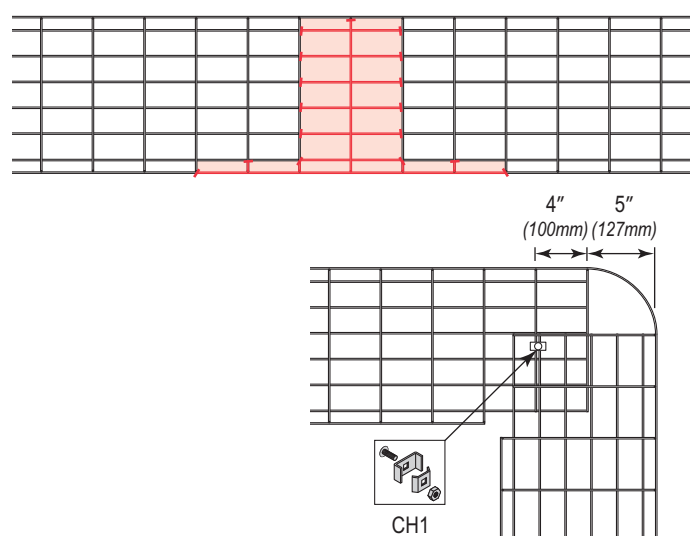

90° BENDS - CUTTING DIAGRAMS

16" (400mm)

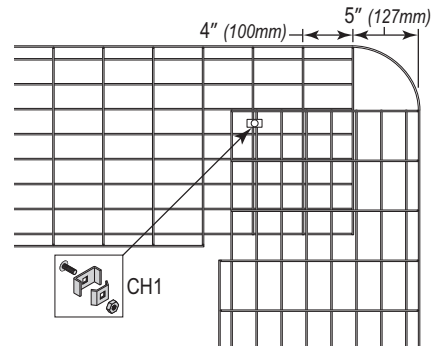
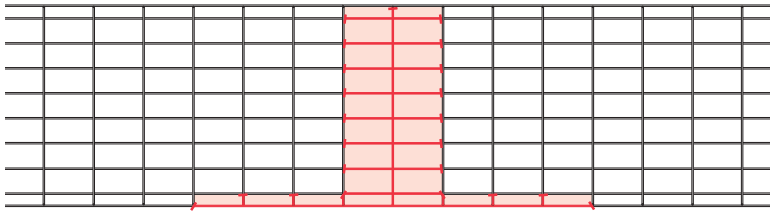

18" (450mm)

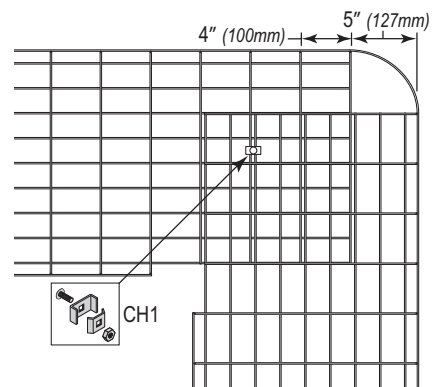
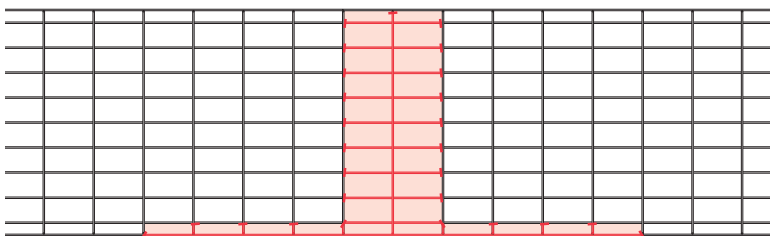

20" (500mm)

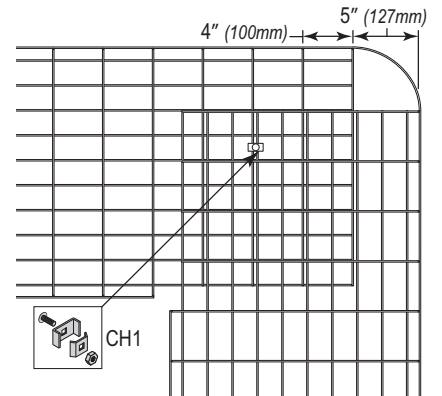
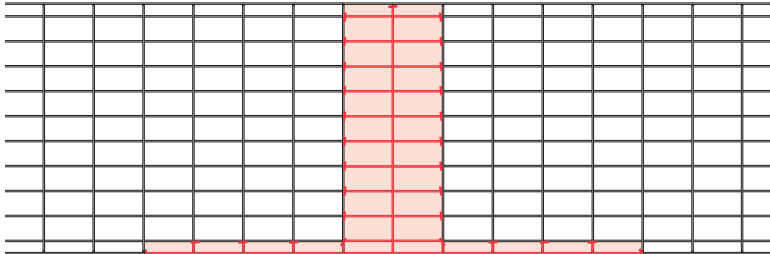

24" (600mm)

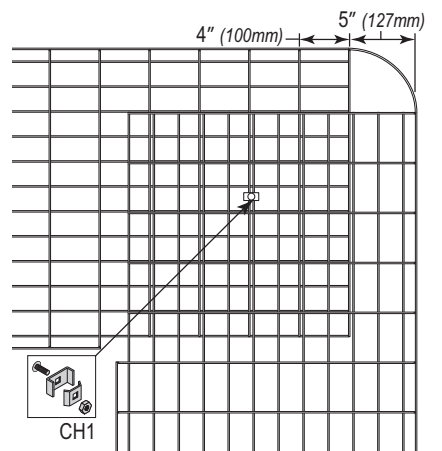
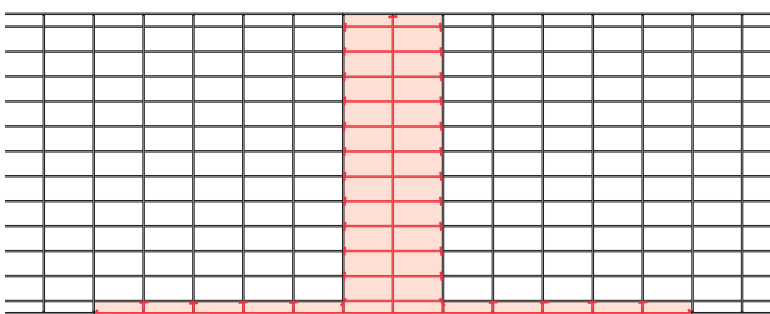

WIRE BASKET SYSTEM

CROSS & TEE FITTINGS

STANDARD TEE

- Standard use per tee is:
(2 pc) T-Bar-22 or (1 pc) T-Bar cut in half
(8 pc) CH3

NOTE: Always place nut on outside of tray

To form a tee, cut the wires marked in red.

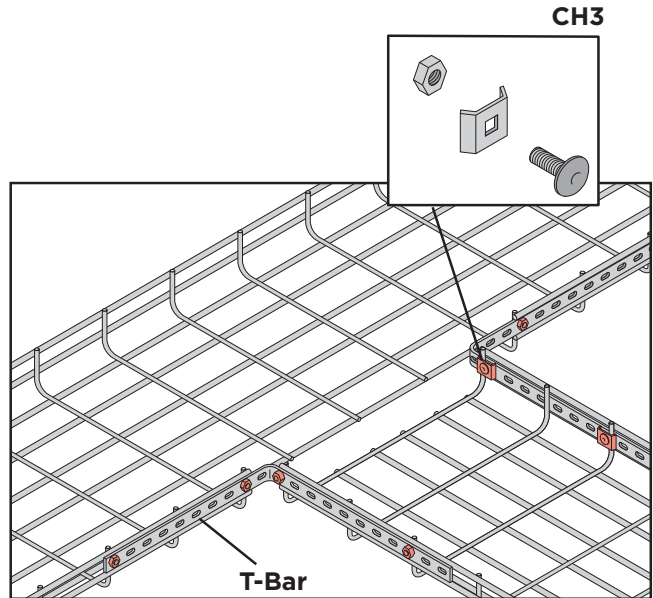
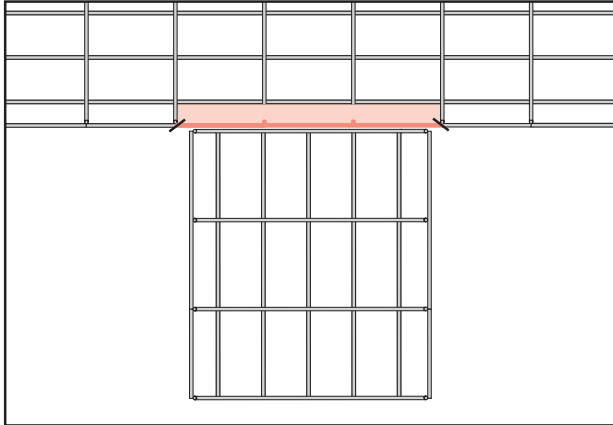

CROSS

- Standard use per cross is:
(4 pc) T-Bar-22 or (2 pc) T-Bar cut in half
(16 pc) CH3

NOTE: Always place nut on outside of tray

To form a cross, cut the wires marked in red.

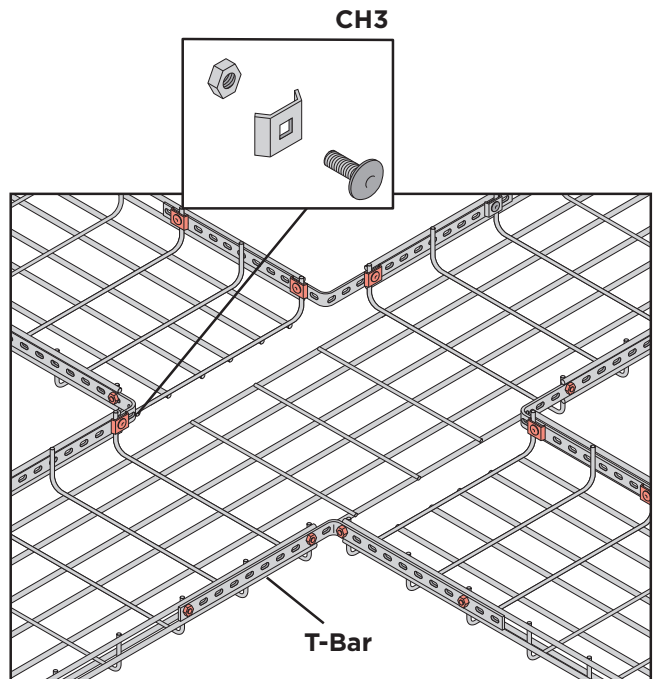
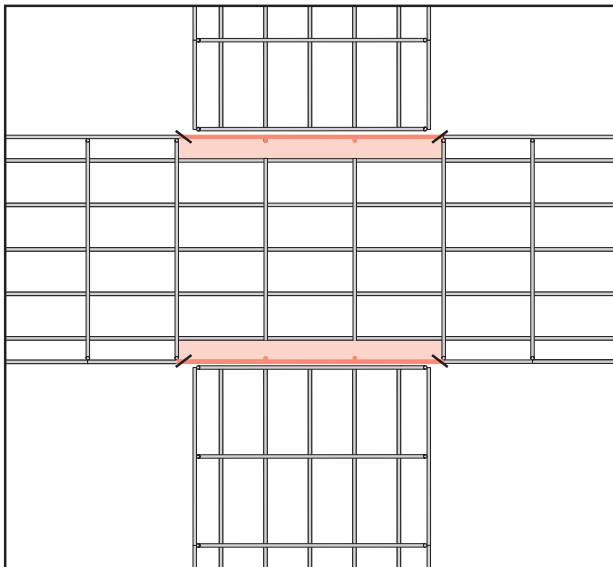

RISER, REDUCER & OFFSET FITTINGS

REDUCER

- Standard use per reducer is:
(2 pc) T-bar
(8 pc) CH3
(1 pc) CH2

NOTE: Always place nut on outside of tray

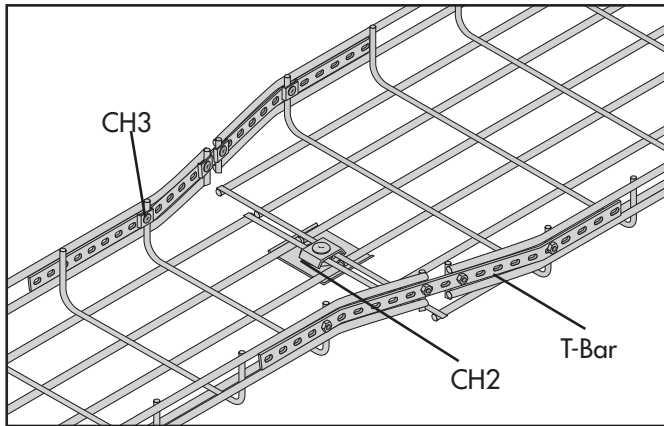
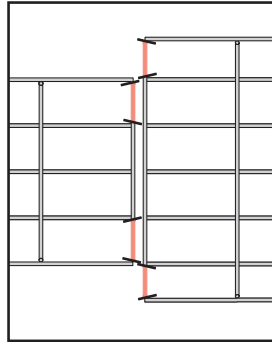

OFFSET

- Standard use per reducer is:
(2 pc) T-bar
(8 pc) CH3
(1 pc) CH2

NOTE: Always place nut on outside of tray

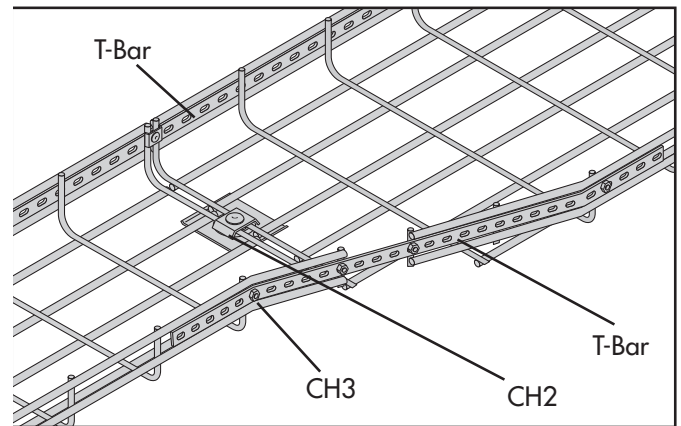
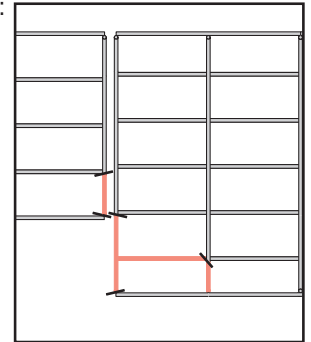

RISER

Cut out 4 side sections of mesh for a soft 90° bend.

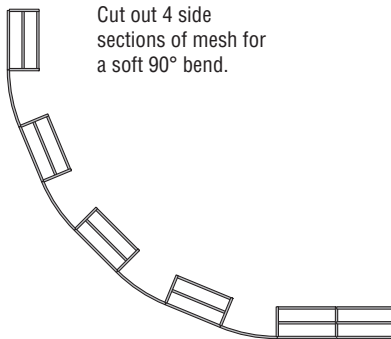

Cut out 3 side sections of mesh for a 90° bend.

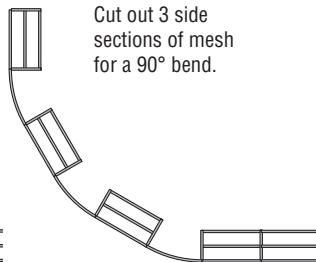

Cut out 2 side sections of mesh for a 90° bend.

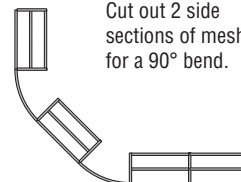

Cut out 1 side sections of mesh for a hard 90° bend.

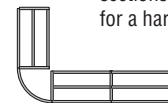

Risers and drops can be created to avoid different obstacles in the job path. Simply cut out the required number of side mesh sections and bend a vertical riser or drop to fit the application.

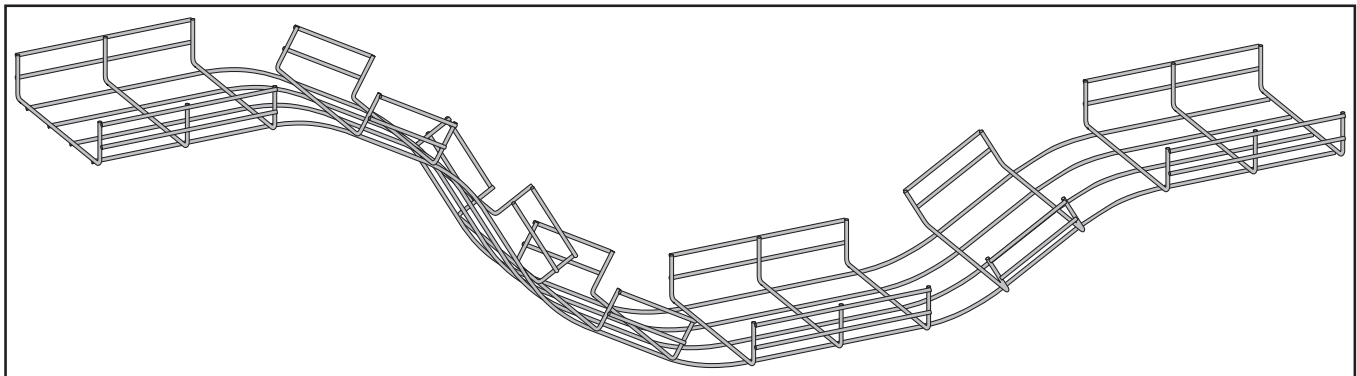

WIRE BASKET SYSTEM

GROUNDING

GROUNDING

UL CLASSIFIED SYSTEMS

Cope® Wire Basket systems meet the UL Classification.

NOTES: Cope® recommends use of a separate ground wire for equipment grounding.

Any non-conductive coating to wire basket must be removed by the contractor/end-user to maintain electrical continuity.

STRAIGHT SECTIONS - The grounding of two straight sections requires the use of (2) CAT-GC's and (2) EG-CBN's.

These items consist of grounding clips and the appropriate hardware, for connecting to the trays. One clip should be placed on both sides of the tray, attached at the self-splicing bar.

FITTINGS - Grounding of fittings requires special attention. Typically, fittings are fabricated in the field by cutting straight sections, thus altering the cross sectional area of the tray. A bonding jumper, and/or a T-Bar Splice, along with the appropriate hardware must be used on either side of the fitting to ensure electrical continuity.

Straights

2 pcs of CAT-GC
2 pcs of EG-CBN

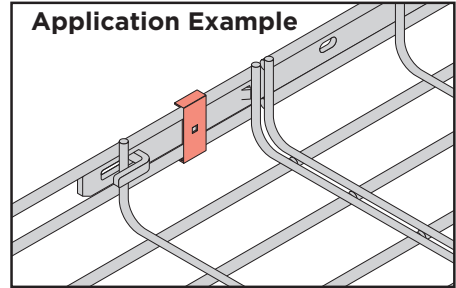
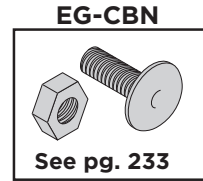

Fittings

T-Bar and
CH3s

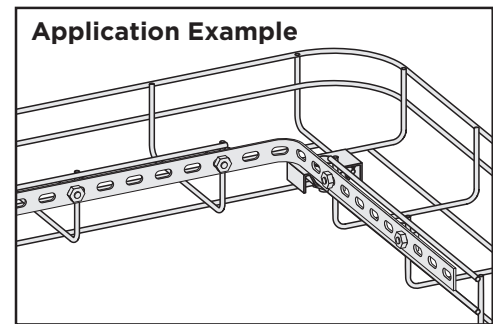

GROUNDING CLIP [CAT-GC]

- Standard finish is pregalvanized (PG)
- Sold in packs of 10
- Connection to splice bars requires a nut and bolt assembly (EG-CBN) purchased separately
- Use on both sides of tray

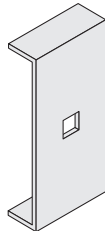

NOTE: Always place nut on outside of tray

CAT-GC's must be utilized if the tray is to be utilized as an equipment ground conductor.

GROUNDING CLAMP/SPLIT BOLT [SPLIT-BOLT]

- Split bolts are utilized for the attachment of a separate ground wire.
- Use with #6 AWG Ground Conductor

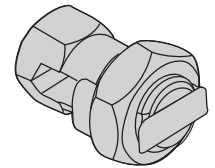

NOTE: Always place nut on outside of tray

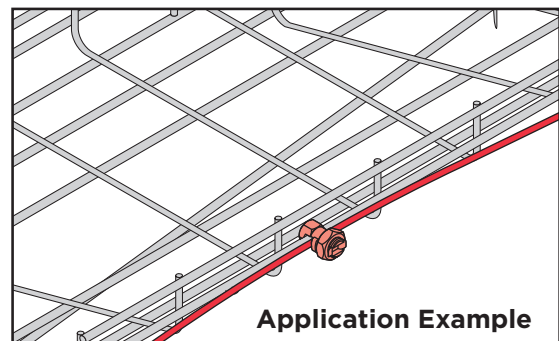

BOTTOM CLIP [BOTTOM-CLIP]

- Bottom-clip used a hold-down clip

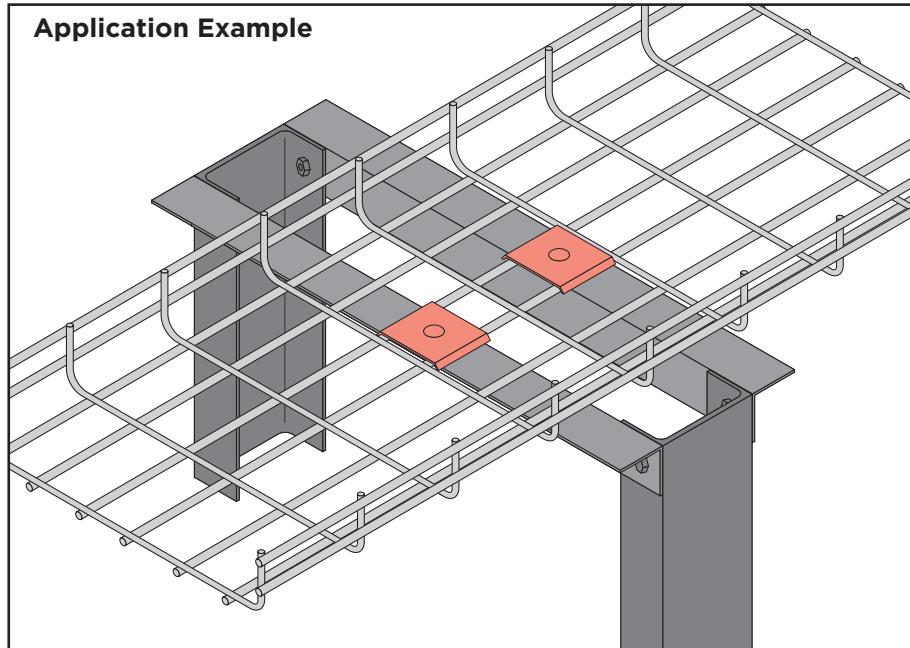
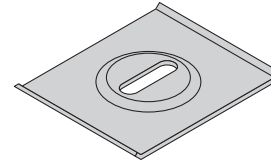

Drill hole in aluminum angle of relay rack.
Use bottom-clip to hold Wire basket tray to relay rack using 1/4"-20 round head machine screw and bolt and washer.

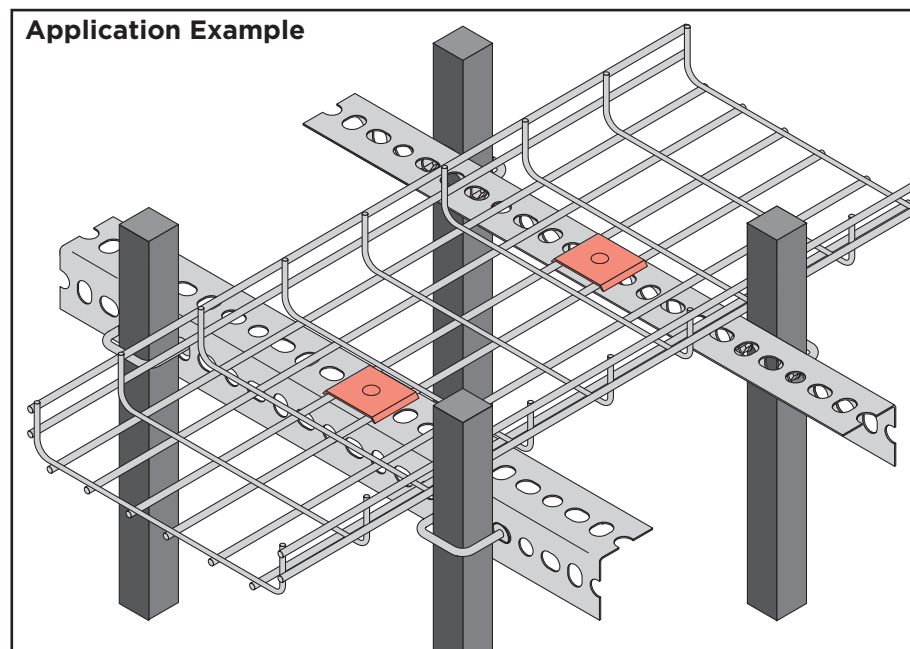

WIRE BASKET SYSTEM

HARDWARE

HEX HEAD CAP SCREWS

- Standard finish is electro-galvanized (EG)

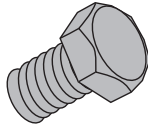

Part No.	Description
PS 6024	1/4"-20 x 1" Long
PS 6024	1/4"-20 x 1-1/2" Long
PS 6024	3/8"-16 x 5/8" Long
PS 6024	3/8"-16 x 1" Long
PS 6024	3/8"-16 x 1-1/2" Long
PS 6024	3/8"-16 x 2" Long

ROUND HEAD MACHINE SCREWS

- Standard finish is electro-galvanized (EG)



Part No.	Description
PS 6072	1/4"-20 x 1" Long
PS 6072	1/4"-20 x 1-1/2" Long
PS 6072	3/8"-16 x 5/8" Long
PS 6072	3/8"-16 x 1" Long
PS 6072	3/8"-16 x 1-1/2" Long
PS 6072	3/8"-16 x 2" Long

HEX NUTS

- Standard finish is electro-galvanized (EG)

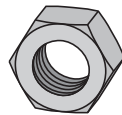

Part No.	Description
PS 83	1/4"-20
PS 83	3/8"-16
PS 83	1/2"-13

SQUARE NUTS

- Standard finish is electro-galvanized (EG)

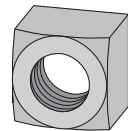

Part No.	Description
PS 6108	1/4" - 20
PS 6108	3/8" - 16
PS 6108	1/2" - 13

FLAT WASHERS

- Standard finish is electro-galvanized (EG)

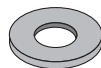

Part No.	Description
PS 209	1/4"
PS 209	3/8"
PS 209	1/2"

LOCK WASHERS

- Standard finish is electro-galvanized (EG)



Part No.	Description
PS 211	1/4"
PS 211	3/8"
PS 211	1/2"

STRUT NUTS

- Standard finish is electro-galvanized (EG)

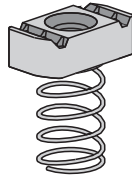

Part No.	Description
PSRS-1/4	1/4" - 20
PSRS-3/8	3/8" - 16
PSRS-1/2	1/2" - 13

SQUARE STRUT WASHERS

- Standard finish is electro-galvanized (EG)

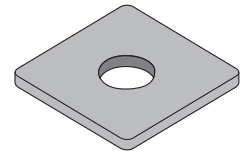

Part No.	Description
PS 619	1/4" hole
PS 619	3/8" hole
PS 619	1/2" hole

TRAY CLIPS (SEE PAGE 233 FOR CONNECTOR KITS)

- Standard finish is electro-galvanized (EG)

Single Part	Weight	No./ Pkg.
Short-Clip	0.2	10
Wide-Clip	0.31	10
Bottom-Clip	0.92	10

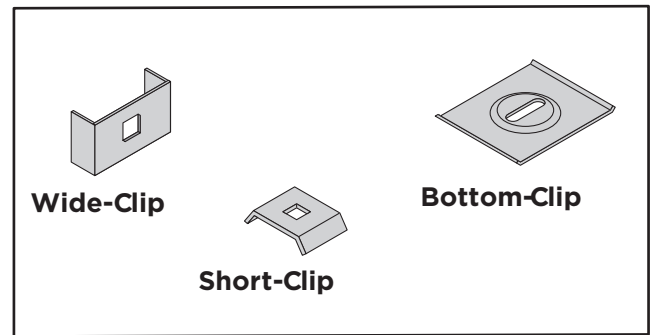

THREADED ROD

- Standard finish is electro-galvanized (EG)

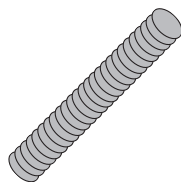

Part No.	Description	Weight		
		6' Lengths	10' Lengths	12' Lengths
PS 146	1/4" - 20	73	121	146
PS 146	3/8" - 16	175	292	350
PS 146	1/2" - 13	319	531	638

SAMPLE SPECIFICATION

1.0 ACCEPTABLE MANUFACTURER

Provide Cope® Wire Basket type of cable management system as manufactured by Atkore International or engineered approved equal.

All cable trays shall be installed in a neat uniform fashion. Installing contractor shall field modify tray system to accommodate the exact routing requirements.

2.0 MATERIAL/FINISHES

Wire basket tray to be fabricated from high strength steel wires.

2.1 Acceptable finishes;

2.1.a Standard Finish

EG – Electro-Galvanized Steel in accordance with ASTM 633 Type I SC3.

2.1.b Special Finishes

HD – Hot dipped Galvanized Steel in accordance with ASTM 123.

ZD – Electro- Galvanized Steel with a Yellow Dichromate applied over the Standard EG finish per ASTM633 type II, SC3.

EP – Epoxy Coated Steel.

SS – AISI 304L stainless or AISI 316L stainless steel.

3.0 - STRAIGHT SECTIONS

Straight sections shall be manufactured from high strength steel wires forming 2" X 4" openings and shall conform to the following dimensions

3.1 Length

Straight sections shall be supplied in 10' lengths

3.2 Width

Widths shall be 2", 4", 6", 8", 12", 16", 18", 20", or 24" as called out on drawings.

3.3 - Load depths

The load depths shall include 2", 4", & 6" as required.

4.0 SPLICES

All straight sections shall be supplied with pre-installed, auto-locking, splices plates, where possible, as per Cope® brand. Trays design shall allow for a snap together type connection and shall require no nut and bolt assembly.

5.0 FITTINGS

All fittings shall be fabricated in the field as required, per manufacturer's recommendations. Radius of the fittings shall be based on the "minimum bending" radius of the cables being installed.

6.0 ACCESSORIES

Accessories such as blind ends, dropouts, and barriers, etc... shall be installed as specified on drawings.

7.0 SUPPORTS

Supports shall include, but are not limited to, center type, trapeze type, wall supports and floor supports.

7.1 Auto Locking

All supports shall be supplied with an Auto locking feature, requiring no special tools for attachment of the trays.

7.2 Finish

All supports, including threaded rod and associated hardware shall be electro-galvanized coated to ASTM B633 SC1 or ASTM B633 SC3.

11

REFERENCE DATA

COPE® QUOTATION CHECK LIST



A PART OF **atkore**
INTERNATIONAL

COPE® Quotation Check List

PROJECT INFORMATION

Name:		Date:	
Contractor:		Location:	
Distributor:			
Contact:			
Email/Phone:			

TRAY TYPE:	<input type="checkbox"/> Ladder	<input type="checkbox"/> Marine Rung	<input type="checkbox"/> Vent Trof	<input type="checkbox"/> Solid Trof
	<input type="checkbox"/> Channel	<input type="checkbox"/> Wire Basket	<input type="checkbox"/> I-Beam	

TRAY MATERIAL:	<input type="checkbox"/> Aluminum	<input type="checkbox"/> Steel, Pre-Galvanized	<input type="checkbox"/> Steel, HDGAF	<input type="checkbox"/> Other, _____
	<input type="checkbox"/> 304 Stainless Steel	<input type="checkbox"/> 316 Stainless Steel	<input type="checkbox"/> Fiberglass	

TRAY MATERIAL: <small>(Fiberglass Only)</small>	<input type="checkbox"/> Polyester	<input type="checkbox"/> Vinyl Ester	
---	------------------------------------	--------------------------------------	--

TRAY LENGTH:	<input type="checkbox"/> 10'	<input type="checkbox"/> 12'	<input type="checkbox"/> 20'	<input type="checkbox"/> 24'	<input type="checkbox"/> 30'
---------------------	------------------------------	------------------------------	------------------------------	------------------------------	------------------------------

TRAY WIDTH:	<input type="checkbox"/> 6"	<input type="checkbox"/> 9"	<input type="checkbox"/> 12"	<input type="checkbox"/> 18"
	<input type="checkbox"/> 24"	<input type="checkbox"/> 30"	<input type="checkbox"/> 36"	<input type="checkbox"/> 42" or <input type="checkbox"/> 48" <small>Note: Ladder Tray Only, not NEMA Standard</small>

TRAY WIDTH: <small>(Wire basket Only)</small>	<input type="checkbox"/> 2"	<input type="checkbox"/> 4"	<input type="checkbox"/> 6"	<input type="checkbox"/> 8"	<input type="checkbox"/> 12"	<input type="checkbox"/> 16"	<input type="checkbox"/> 18"	<input type="checkbox"/> 20"	<input type="checkbox"/> 24"
---	-----------------------------	-----------------------------	-----------------------------	-----------------------------	------------------------------	------------------------------	------------------------------	------------------------------	------------------------------

RUNG SPACING:	<input type="checkbox"/> 6"	<input type="checkbox"/> 9"	<input type="checkbox"/> 12"	<input type="checkbox"/> 18"
----------------------	-----------------------------	-----------------------------	------------------------------	------------------------------

LOAD DEPTH:	<input type="checkbox"/> 2"	<input type="checkbox"/> 3"	<input type="checkbox"/> 4"	<input type="checkbox"/> 5"	<input type="checkbox"/> 6"
--------------------	-----------------------------	-----------------------------	-----------------------------	-----------------------------	-----------------------------

FITTING RADIUS:	<input type="checkbox"/> 12"	<input type="checkbox"/> 24"	<input type="checkbox"/> 36"
------------------------	------------------------------	------------------------------	------------------------------

STRUCTURAL REQUIREMENTS: <small>(NEMA CLASS)</small>	<input type="checkbox"/> 8A	<input type="checkbox"/> 8B	<input type="checkbox"/> 8C	
	<input type="checkbox"/> 12A	<input type="checkbox"/> 12B	<input type="checkbox"/> 12C	
OR,	<input type="checkbox"/> 16A	<input type="checkbox"/> 16B	<input type="checkbox"/> 16C	
	<input type="checkbox"/> 20A	<input type="checkbox"/> 20B	<input type="checkbox"/> 20C	

CABLE WEIGHT SUPPORT SPAN:	
-----------------------------------	--

SPECIAL REQUIREMENTS:	
------------------------------	--

DELIVERY REQUIREMENTS:	
-------------------------------	--

All tray widths and lengths listed are not available for every tray type. See Cope catalog for dimensions.

Customer Service
 16100 S. Lathrop Ave. • Harvey, IL 60426
 Phone: 800-882-5543 • Fax: 708-339-7814
www.copetray.com

Confidential Information COP-L-1005-1404

CABLE TRAY/WIRE BASKET LOADINGS REFERENCE

NEMA (VE-1) Loadings¹

Tray/Load Designation	Class A	Class B	Class C
lbs/ft	50	75	100

Power Cables^{1,2}

Tray Dimension	36" Wide	30" Wide	24" Wide	18" Wide	12" Wide	9" Wide	6" Wide
Cable Fill Weight	140	115	90	70	45	35	25

Data/Communication Cables^{1,3,4}

Tray Size	36" Wide	30" Wide	24" Wide	18" Wide	12" Wide	9" Wide	6" Wide
6" Depth	89	74	59	45	30	23	15
5" Depth	74	62	49	37	25	19	13
4" Depth	59	49	40	30	20	15	10
3" Depth	45	37	30	23	15	12	8
2" Depth	30	25	20	15	10	8	5

Note:

1. All Cable Weight/Loads are in Lbs/ft unless otherwise noted.
2. Larger diameter cables used in weight estimation.
3. Max 50% fill ratio used in calculations for Data/Communication Cables
4. CAT6/CAT6E cables, O.D. = 0.25" nominal, weight = 0.040 lbs/ft

CORROSION RESISTANCE GUIDE

The symbols to the right have been used throughout the table in order to provide an indication about the suitability of a potential candidate material for a specific chemical environment.

NOTE: These tables should be regarded only as GUIDES to anticipated performance because of possible contributions from temperature, pollutant (contaminant) species, etc.

SYMBOLS:

++	First choice; very low corrosion rate, typically <5 mpy, or <0.005 Inch/year, (1 mil = 1/1000 inch).
+	Good choice; low corrosion rate, typically <20 mpy, or <0.02 lpy.
-	Can use; corrosion rate up to 50 mpy (0.05 lpy); some limitations may apply.
X	Not recommended.
(-)	Brackets indicate probable limitations, E.G., At higher temperatures, [symbol "T"]; at higher concentrations, [symbol "C"]; due to pitting, [symbol "P"]; due to local grain boundary attack in the metal - intergranular corrosion, [symbol "I"]; due to stress corrosion cracking, [symbol "S"].
nd	No available data

Corrosion Resistance Guide			
Chemical Species	Aluminum	HDG/Steel	316SS
Acetaldehyde	++	+	++
Acetic acid - aerated	(+) ^{TC}	X	(++) ^T
Acetic acid - not aerated	(+) ^{TC}	X	(++) ^T
Acetone	++	++	++
Acetylene	++	nd	++
Allyl alcohol	+	nd	++
Aluminum chloride - dry	+	nd	(+) ^{TP}
Aluminum chloride - wet	X	X	(-) ^P
Aluminum sulfate - satd.	X	nd	+
Ammonia - anhydrous	++	++	++
Ammonia - gas	-	+	(+) ^T
Ammonium acetate	+	nd	+
Ammonium bicarbonate	-	nd	(+) ^T
Ammonium carbonate - satd.	+	X	+
Ammonium chloride - 28%	X	X	(+) ^{PS}
Ammonium chloride - 50%	X	X	X
Ammonium hydroxide	+	+	(++) ^C
Ammonium nitrate	+	X	(++) ^S
Ammonium phosphate - 40%	X	nd	+
Ammonium sulfate - to 30%	X	-	+
Amyl acetate	++	++	++
Asphalt	++	+	+
Beer	++	X	++
Benzene (benzol)	++	+	(+) ^P
Benzoic acid	+	nd	+
Benzol - see benzene			
Boric acid (boracic acid)	++	nd	(++) ^{TP}
Bromine - wet	X	X	X
Butadiene (butylene)	+	+	+
Butyl alcohol (butanol)	++	++	++
Butyric acid	+	X	+
Cadmium sulfate	+	nd	++

Corrosion Resistance Guide			
Chemical Species	Aluminum	HDG/Steel	316SS
Calcium carbonate	-	nd	+
Calcium chloride - satd.	+	X	(+) ^S
Calcium hydroxide - satd.	X	nd	+
Calcium hypochlorite - satd.	X	X	(-) ^P
Carbon dioxide - wet	++	+	+
Carbon disulfide (bisulfide)	++	+	++
Carbon tetrachloride	X	+	(++) ^{PS}
Carbolic acid - see phenol			
Carbonic acid - see carbon dioxide			
Caustic potash - see potassium hydroxide	X	++	(-) ^{PS}
Caustic soda - see sodium hydroxide			
Chlorine gas - wet			
Chloroform	(+) ^{dry}	+	(+) ^{TS}
Chromic acid	+	nd	(+) ^P
Citric acid - dilute	(+) ^{TC}	X	(++) ^P
Copper chloride	X	X	(-) ^P
Copper nitrate	X	nd	++
Copper sulfate	X	-	+
Cresol	+	+	+
Crude oil	++	++	++
Diethylamine	+	++	++
Dimethyl ketone - see acetone			
Ethyl acetate	(++) ^{dry}	++	+
Ethyl alcohol (ethanol)	++	++	++
Ethylene dichloride	(-) ^{dry}	++	(+) ^{PS}
Ethylene glycol (glycol)	++	++	++
Ferric chloride	X	X	X
Ferric nitrate - 10%	X	nd	+
Ferrous sulfate	+	nd	(+) ^P
Formaldehyde (methanal)	(+) ^P	++	(++) ^{TC}
Fluorine gas - moist	X	X	X
Formalin - see formaldehyde			
Formic acid (methanoic acid) - 10%	(+) ^T	X	(+) ^{PC}
Furfural (furfuraldehyde)	+	nd	+

CORROSION RESISTANCE GUIDE

Corrosion Resistance Guide			
Chemical Species	Aluminum	HDG/Steel	316SS
Furoil - see furfural Gelatin	++	+	++
Glycerine (glycerol)	++	++	++
Hexamine - 80%	++	nd	++
Hydrobromic acid	X	X	X
Hydrochloric acid (muriatic acid)	X	X	X
Hydrocyanic acid - dilute	+	nd	+
Hydrocyanic acid - conc	X	nd	+
Hydrofluoric acid	X	X	X
Hydrogen chloride gas - dry	X	X	(++) ^S
Hydrogen chloride gas - wet	X	X	+
Hydrogen fluoride	(-) ^T	nd	+
Hydrogen peroxide - to 40%	++	nd	+
Hydrogen sulfide - wet	(+) ^P	nd	(+) ^{PS}
Hypo - see sodium thiosulfate	X	X	X
Hypochlorous acid	X	X	X
Iodine solution - satd	X	X	X
Lactic acid	(+) ^T	nd	(+) ^{PI}
Latex	++	-	++
Lithium chloride - to 30%	X	nd	++
Linseed oil	+	nd	++
Magnesium chloride - 50%	X	X	(+) ^{PS}
Magnesium hydroxide	+	nd	++
Magnesium sulfate	+	X	+
Maleic acid (maleinic acid) - 20%	+	nd	+
Methyl alcohol (methanol)	++	++	++
Methyl ethyl ketone	+	++	+
Milk	++	X	++
Molasses	+	nd	++
Naptha	+	+	+
Natural fats	++	++	++
Nickel chloride	X	nd	(+) ^{PS}
Nickel sulfate	X	nd	+
Nitric acid	X	X	(++)
IOleic acid	(++) ^T	nd	++
Oxalic acid - dilute	-	nd	+
Oxalic acid - saturated	(+) ^T	X	X
Paraformaldehyde - to 30%	+	nd	++
Perchloroethylene	+	X	(++)
PPhenol (carbolic acid)	+	+	++
Phosphoric acid - dilute	X	X	++
Phosphoric acid - 50%	X	X	(++)
IPicric acid	++	nd	+
Potassium bicarbonate - 30%	X	nd	++
Potassium carbonate	X	nd	++
Potassium chloride - to 25%	X	X	(++) ^P

Corrosion Resistance Guide			
Chemical Species	Aluminum	HDG/Steel	316SS
Potassium dichromate - 30%	(++) ^T	X	++
Potassium hydroxide	X	nd	(+) ^S
Potassium nitrate	++	++	+
Potassium sulfate	++	++	++
Propionic acid (propanoic acid)	(+) ^T	X	(+) ^T
Propyl alcohol (propane)	++	++	++
Prussic acid - see hydrocyanic acid	+	nd	++
Pyridine	+	nd	++
Soaps	+	-	+
Sodium bicarbonate - 20%	+	nd	++
Sodium bisulfate	X	X	(+) ^T
Sodium bisulfite	X	X	+
Sodium chloride - to 30%	X	X	(+) ^{PS}
Sodium cyanide	X	nd	(+) ^T
Sodium hydroxide - 10-30%	X	X	(+) ^S
Sodium hydroxide - 50%	X	X	(++) ^S
Sodium hydroxide - conc	X	X	++
Sodium hypochlorite - conc	X	+	(-) ^{PS}
Sodium nitrate	++	X	++
Sodium peroxide - 10%	+	nd	+
Sodium silicate	++	nd	++
Sodium sulfate	(++) ^{30%}	X	++
Sodium sulfide - to 50%	X	nd	(+) ^T
Sodium thiosulfate	+	nd	++
Steam	(+) ^P	++	++
Stearic acid	+	nd	++
Sorbital (hexahydric alcohol)	++	+	++
Sulfur dioxide - dry	+	+	++
Sulfur dioxide - wet	X	X	(+) ^T
Sulfuric acid - to 80%	X	X	X
Sulfuric acid - 80-90%	X	X	(-) ^I
Sulfuric acid - 98%	X	X	(+) ^I
Tannic acid (tannin)	X	X	+
Tartaric acid - to 50%	(+) ^T	nd	++
Toluene (Toluol; methyl benzene)	++	++	++
Trichloroethylene	(++) ^T	+	(+) ^P
Turpentine	+	++	++
Water - acid, mine	X	-	(++) ^P
Water - potable	+	+	++
Water - sea	+	+	++
Xylene	++	nd	++
Zinc chloride - dilute	++	nd	(++) ^{PS}

NOTE: These tables should be regarded only as GUIDES to anticipated performance because of possible contributions from temperature, pollutant (contaminant) species, etc.

TABLE OF CONVERSIONS

English to Metric			Metric to English		
To Convert From	To	Multiply By	To Convert From	To	Multiply By
Length					
Inch [in]	Millimeter [mm]	25.400 000	Millimeter [mm]	Inch [in]	0.039 370
Foot [ft]	Meter [m]	0.304 800	Meter [m]	Foot [ft]	3.280 840
Yard [yd]	Meter [m]	0.914 400	Meter [m]	Yard [yd]	1.093 613
Mile (U.S. Statute) [mi]	Kilometer [km]	1.609 347	Kilometer [km]	Mile (U.S. Statute) [mi]	0.621 370
Area					
Square Inch [in ²]	Square Millimeter [mm ²]	645.16	Square Millimeter [mm ²]	Square Inch [in ²]	0.001550
Square Foot [ft ²]	Square Meter [m ²]	0.092 903	Square Meter [m ²]	Square Foot [ft ²]	10.763 915
Square Yard [yd ²]	Square Meter [m ²]	0.836 127	Square Meter [m ²]	Square Yard [yd ²]	1.195 991
Square Mile [mi ²] (U.S. Statute)	Square Kilometer [km ²]	2.589 998	Square Kilometer [km ²]	Square Mile [mi ²] (U.S. Statute)	0.386 101
Acre	Square Meter [m ²]	4,046.873	Square Meter [m ²]	Acre	0.000 247
Acre	Hectare	0.404 687	Hectare	Acre	2.471 046
Volume					
Cubic Inch [in ³]	Cubic Millimeter [mm ³]	16,387.06	Cubic Millimeter [mm ³]	Cubic Inch [in ³]	0.000061
Cubic Foot [ft ³]	Cubic Meter [m ³]	0.028 317	Cubic Meter [m ³]	Cubic Foot [ft ³]	35.314 662
Cubic Yard [yd ³]	Cubic Meter [m ³]	0.764 555	Cubic Meter [m ³]	Cubic Yard [yd ³]	1.307 950
Gallon (U.S. Liquid) [gal]	Litre [l]	3.785 412	Litre [l]	Gallon (U.S. Liquid) [gal]	0.264 172
Quart (U.S. Liquid) [qt]	Litre [l]	0.946 353	Litre [l]	Quart (U.S. Liquid) [qt]	1.056 688
Mass					
Ounce (Avoirdupois) [oz]	Gram [g]	28.349 520	Gram [g]	Ounce (Avoirdupois) [oz]	0.035 274
Pound (Avoirdupois) [lb]	Kilogram [kg]	0.453 592	Kilogram [kg]	Pound (Avoirdupois) [lb]	2.204 624
Short Ton	Kilogram [kg]	907.185	Kilogram [kg]	Short Ton	0.00110
Force					
Ounce-Force	Newton [N]	0.278 014	Newton [N]	Ounce-Force	3.596 941
Pound-Force [lbf]	Newton [N]	4.448 222	Newton [N]	Pound-Force [lbf]	0.224 809
Bending Moment					
Pound-Force-Inch [lbf-in]	Newton-Meter [N-m]	0.112 985	Newton-Meter [N-m]	Pound-Force-Inch [lbf-in]	8.850 732
Pound-Force-Foot [lbf-ft]	Newton-Meter [N-m]	1.355 818	Newton-Meter [N-m]	Pound-Force-Foot [lbf-ft]	0.737 562
Pressure, Stress					
Pound-Force per Square Inch [lbf/in ²]	Kilopascal [kPa]	6.894 757	Kilopascal [kPa]	Pound-Force per Square Inch [lbf/in ²]	0.145 038
Foot of Water (39.2 F)	Kilopascal [kPa]	2.988 980	Kilopascal [kPa]	Foot of Water (39.2 F)	0.334 562
Inch of Mercury (32 F)	Kilopascal [kPa]	3.386 380	Kilopascal [kPa]	Inch of Mercury (32 F)	0.295 301
Energy, Work, Heat					
Foot-Pound-Force [ft-lbf]	Joule [J]	1.355 818	Joule [J]	Foot-Pound-Force [ft-lbf]	0.737 562
British Thermal Unit [Btu]	Joule [J]	1,055.056	Joule [J]	British Thermal Unit [Btu]	0.000948
Calorie [cal]	Joule [J]	4.186 800	Joule [J]	Calorie [cal]	0.238 846
Kilowatt Hour [kW-h]	Joule [J]	3,600,000	Joule [J]	Kilowatt Hour [kW-h]	2.78 ⁻⁷
Power					
Foot-Pound-Force /Second [ft-lbs/s]	Watt [W]	1.355 818	Watt [W]	Foot-Pound-Force /Second [ft-lbs/s]	0.737 562
British Thermal Unit /Hour [Btu/h]	Watt [W]	0.293 071	Watt [W]	British Thermal Unit /Hour [Btu/h]	3.412 142
Horsepower (550 Ft. Lbf/s) [hp]	Kilowatt [kW]	0.745 700	Kilowatt [kW]	Horsepower (550 Ft. Lbf/s) [hp]	1.341 022
Angle					
Degree	Radian [rad]	0.017 453	Radian [rad]	Degree	57.295 788
Temperature					
Degree Fahrenheit [F]	Degree Celsius [C]	(F° -32)/1.8	Degree Celsius [C]	Degree Fahrenheit [F]	1.8xC°+32

FRACTIONS & DECIMAL EQUIVALENTS

	1/64	0.015625		33/64	0.515625	
	1/32	0.03125		17/32	0.53125	
		3/64	0.046875		35/64	0.546875
1/16			0.0625	9/16		0.5625
		5/64	0.078125		37/64	0.578125
	3/32		0.09375		19/32	0.59375
		7/64	0.109375		39/64	0.609375
1/8			0.125	5/8		0.625
		9/64	0.140625		41/64	0.640625
	5/32		0.15625		21/32	0.65625
		11/64	0.171875		43/64	0.671875
3/16			0.1875	11/16		0.6875
		13/64	0.203125		45/64	0.703125
	7/32		0.21875		23/32	0.71875
		15/64	0.234375		47/64	0.734375
1/4			0.25	3/4		0.75
		17/64	0.265625		49/64	0.765625
	9/32		0.28125		25/32	0.78125
		19/64	0.296875		51/64	0.796875
5/16			0.3125	13/16		0.8125
		21/64	0.328125		53/64	0.828125
	11/32		0.34375		27/32	0.84375
		23/64	0.359375		55/64	0.859375
3/8			0.375	7/8		0.875
		25/64	0.390625		57/64	0.890625
	13/32		0.40625		29/32	0.90625
		27/64	0.421875		59/64	0.921875
7/16			0.4375	15/16		0.9375
		29/64	0.453125		61/64	0.953125
	15/32		0.46875		31/32	0.96875
		31/64	0.484375		63/64	0.984375
1/2			0.5	1		1.

LADDER - PART NUMBER INDEX

Part Number.....	Page	Part Number.....	Page	Part Number.....	Page
9053.....	107	9057-EP.....	104	OB.....	106
9156.....	104	9057-SS.....	104	OT.....	49
01FB-06.....	106	9131.....	107	P200.....	110
01SB-12.....	106	9131A.....	107	PC.....	103
06BE.....	104	9131-DC.....	107	PF.....	102
06CB.....	104	9131-HDW.....	107	PH.....	102
06DO.....	104	9131-IP.....	107	PS.....	102
06SL.....	102	9131L.....	107	PS 135.....	101
09BE.....	104	9132.....	107	PS 135X.....	103
09CB.....	104	9133.....	107	PS 146.....	101
09DO.....	104	9F.....	36	PS 209.....	101
09SL.....	102	9I.....	47	PS 211.....	101
12BE.....	104	90.....	47	PS 230.....	101
12CB.....	104	AF.....	46	PS 6024.....	101
12DO.....	104	BE.....	104	PS 6072.....	101
12SL.....	102	BSP.....	106	PS 6108.....	101
18BE.....	104	BSP-L.....	106	PS 651-12.....	108
18CB.....	104	CA.....	100	PS 651-15.....	108
18DO.....	104	CB.....	104	PS 651-18.....	108
18SL.....	102	CBJ.....	104	PS 651-24.....	108
24BE.....	104	CBJ-250C.....	104	PS 651-30.....	108
24CB.....	104	CBJ-4C.....	104	PS 651-36.....	108
24DO.....	104	CBJ-C.....	104	PS 651-6.....	108
24SL.....	102	CC.....	103	PS 809-12.....	108
30BE.....	104	CCB-050.....	105	PS 809-15.....	108
30CB.....	104	CCB-075.....	105	PS 809-18.....	108
30DO.....	104	CCB-100.....	105	PS 809-24.....	108
30S.....	102	CCB-125.....	PS 809-30.....	108
36BE.....	104	CCB-150.....	105	PS 809-36.....	108
36CB.....	104	CCB-175.....	105	PS 809-42.....	108
36DO.....	104	CCB-200.....	105	PS 83.....	101
36SL.....	102	CCS-SS.....	102	PS 838R-10.....	108
3F.....	37	CE.....	100	PS 838R-12.....	108
3I.....	48	CH.....	100	PS 838R-16.....	108
3O.....	48	CO.....	100	PS 838R-18.....	108
4F.....	37	CV.....	100	PS 838R-24.....	108
4I.....	48	DC.....	103	PS 838R-30.....	108
4O.....	48	DO.....	104	PS 838R-6.....	108
58-02RC-MID.....	100	EM.....	101	PS 838R-8.....	108
6-9053.....	107	EM-CC.....	103	PV.....	102
6F.....	36	EM-CC-SS.....	103	RC.....	100
6I.....	47	FB.....	106	RH.....	44
6O.....	47	FC.....	39	RY.....	46
7-HGR1.....	109	FL.....	102	SB.....	106
8-9053.....	107	FS.....	102	SB-HDW.....	106
8-HGR1.....	109	FT.....	38	SR.....	49
9025-98.....	108	HS.....	102	ST.....	45
9036-31.....	109	HV.....	102	T200E.....	110
9036-37.....	109	IB.....	106	T201E.....	110
9036-45.....	109	JP-06.....	102	TB6209.....	105
9037-12.....	109	JP-09.....	102	TB6210.....	105
9037-18.....	109	JP-12.....	102	TB6211.....	105
9037-24.....	109	JP-120.....	102	TB6214.....	105
9037-30.....	109	JP-18.....	102	TB6216.....	105
9037-36.....	109	JP-24.....	102	TB6218.....	105
9037-42.....	109	JP-30.....	102	TC.....	42-43
9038.....	109	JP-36.....	102	TT.....	40-41
9043.....	108	LH.....	44	VT.....	49
9043-37.....	108	LY.....	46		
9056-EP.....	104	NF.....	102		
9056-SS.....	104	NL.....	102		

LADDER - KEYWORD INDEX

Description.....	Page	Description.....	Page
30° Horizontal Elbow [3F]	37	Hardware.....	101
30° Vertical Elbow Inside [3I]	48	Hex Head Cap Screw [PS 6024]	101
30° Vertical Elbow Outside [3O]	48	Hex Nuts [PS 83].....	101
45° "Y" Branch Left Hand [LY]	46	Horizontal Adjustable Connector [CH]	100
45° "Y" Branch Right Hand [RY].....	46	Horizontal Cross [FC]	39
45° Horizontal Elbow [4F]	37	Horizontal Tapped Cross [TC]	42 - 43
45° Vertical Elbow Inside [4I]	48	Horizontal Tapped Tee [TT]	40 - 41
45° Vertical Elbow Outside [4O]	48	Horizontal Tee [FT]	38
60° Horizontal Elbow [6F]	36	How To Order.....	32
60° Vertical Elbow Inside [6I]	47	Isolation Pad [9131-IP].....	107
60° Vertical Elbow Outside [6O]	47	Joint Plate	102
90° Angle Connector [CA]	50	Left Hand Reducer(LH)	44
90° Horizontal Elbow [9F]	36	Mid-Span Splice Plate [RC]	100
90° Vertical Cable Support Elbow [SR]	49	Nylon Barrier Splice & Protector [BSP-L]	106
90° Vertical Elbow Inside [9I]	47	Ordering information	32
90° Vertical Elbow Outside [9O]	47	Overview	30 - 31
Accessories	104, 105, 107	Peak Cover Connector [PC, VC].....	103
Adjustable Elbow [AF]	46	Reducing Connector [CO].....	100
Aluminum Tray Selection Chart	26 - 27	Right Hand Reducer (RH).....	44
Barrier Strip - Horizontal Fitting [FB]	106	Rod Coupler [PS 135].....	101
Barrier Strip - Straight Section [SB]	106	Seismic Hold-Down [9132].....	107
Barrier Strip Clamp [SB-HDW].....	106	Single Ladder Hangers.....	109
Barrier Strip Vertical Elbow Outside [OB] & Inside [IB].....	106	Single Rod Hanger Support.....	110
Barrier Strips	106	Split-Lock Washers [PS 211]	101
Blind End [BE].....	104	Square Nuts [PS 6108]	101
Bonding Jumper [CBJ].....	104	Stainless Steel Cover Clip [CCS-SS]	103
Box Connector [CB].....	104	Steel Tray Selection Chart	28 - 29
Cable Tray Ground Clamp [9156].....	104	Straight Length	32 - 34
Channel-Type Supports.....	108	Straight Length SL	33
Combination Hold-Down / Expansion Guide [9053]	107	Straight Reducer [ST]	45
Combination Hold-Down Clamp & Expansion Guide [9131]	107	Structural Support Bracket.....	109
Conduit Clamp Bracket	105	Support Brackets & Tray Hangers	109
Conduit-to-Cable Tray Clamp	105	Supports	108
Conduit-to-Cable Tray Clamp Swivel Type	105	Trapeze Hanger Support.....	110
Connector Hardware.....	101	Tray Connectors.....	100
Connector Plates.....	100	Tray Hanger	109
Continuous Threaded Rod [PS 146].....	101	Tray Hanger & Supports	110
Cope Ladder	33	Universal Aluminum Barrier Strip - Straight Section [SB]	106
Cope Swage Ladder.....	30	Universal Curvilinear Connector [RC].....	100
Cover Accessories.....	103	Vertical Adjustable Connector [CV]	100
Cover Connector [CC].....	103	Vertical Supports	108
Cover Screw	107	Vertical Tee - Down [VT].....	49
Cover Screw [EM]	101	Vertical Tee - Up [OT]	49
Covers	102	Vertical Tee Down [VT] & Up [OT]	49
CSA Ordering Information	34	Wall Penetrating Sleeve Assembly.....	105
CSA System Selection Chart	35	Wall Support Brackets.....	109
Double Channel-Type Supports	108		
Double Clamp Connector [(W) DC].....	103		
Drop Out [DO]	104		
Electrical Grounding Chart	50		
Electro-Galv. Steel Cover Clip [PS 135X].....	103		
Elevated Cover Connectors [EM-CC].....	103		
Expansion Connector [CE].....	100		
Fender Washers [PS 230].....	101		
Fittings Ordering Chars	32, 34		
Flat Washers [PS 209].....	101		
Ground Cable Retainer Clamp	104		
Gusset-Type Supports.....	108		

I-BEAM - PART NUMBER INDEX

Part Number.....	Page	Part Number.....	Page	Part Number.....	Page
9132.....	139	9036-37.....	147	PFHA.....	141
9133.....	139	9036-45.....	147	PP.....	141
01CO.....	137	9037-12.....	147	PPHA.....	141
01FB-06.....	145	9037-18.....	147	PS 135.....	140
01SB-10.....	145	9037-24.....	147	PS 135X.....	142
01SB-12.....	145	9037-30.....	147	PS 146.....	140
02CA.....	139	9037-36.....	147	PS 209.....	140
02CE.....	137	9037-42.....	147	PS 211.....	140
02CH.....	137	9053.....	139	PS 230.....	140
02CV.....	138	9056-EP.....	143	PS 6024.....	140
02RC.....	137	9056-SS.....	143	PS 6072.....	140
03CO.....	137	9057-EP.....	143	PS 6108.....	140
04CO.....	137	9057-SS.....	143	PS 651.....	146
06BE.....	143	9131A.....	139	PS 809.....	146
06CB.....	143	9131A-HDW.....	139	PS 83.....	140
06CO.....	137	9131-IP.....	139	PS 838R.....	146
06DO.....	143	9131L.....	139	PS MU.....	144
06SL.....	141	9132.....	139	PS MU-1.....	144
07CO.....	137	9156.....	143	PS MU-1/2.....	144
09BE.....	143	9F.....	122	PS MU-1/4.....	144
09CB.....	143	9I.....	132	PS MU-1-1/2.....	144
09CO.....	137	90.....	132	PS MU-1-1/4.....	144
09DO.....	143	BE.....	143	PS MU-2.....	144
09SL.....	141	BPC.....	138	PS MU-2-1/2.....	144
10CO.....	137	BSP-L.....	145	PS MU-3.....	144
12BE.....	143	CA.....	139	PS MU-3/4.....	144
12CB.....	143	CB.....	143	PS MU-3/8.....	144
12CO.....	137	CBJ.....	143	PS MU-3-1/2.....	144
12DO.....	143	CBJ-250C.....	143	PS MU-4.....	144
12SL.....	141	CBJ-4C.....	143	PS PP.....	147
13CO.....	137	CBJ-C.....	143	PS-MPDS-13HG.....	147
15CO.....	137	CCB.....	139	PS-MPDS-16HG.....	147
18BE.....	143	CE.....	137	PS-MPDS-22HG.....	147
18CB.....	143	CH.....	137	PS-MPDS-28HG.....	147
18CO.....	137	CO.....	137	PS-MPDS-34HG.....	147
18DO.....	143	CV.....	138	PS-MPDS-40HG.....	147
18SL.....	141	DC.....	142	PS-SPSS-10HG.....	147
21CO.....	137	DO.....	143	RC.....	137
24BE.....	143	EM.....	140	RH.....	130
24CB.....	143	EM-CC.....	142	RY.....	131
24CO.....	137	EM-CC-SS.....	142	SB.....	145
24DO.....	143	FB.....	145	SR.....	136
24SL.....	141	FC.....	128	SS89042.....	144
27CO.....	137	FS.....	141	ST.....	130
30BE.....	143	FSHA.....	141	T200E.....	148
30CB.....	143	FT.....	126	T201E.....	148
30CO.....	137	H6A-02RC-MID.....	137	TB.....	144
30DO.....	143	H7A-02RC-MID.....	137	TB6209.....	144
30SL.....	141	H-9043.....	138	TB6211.....	144
36BE.....	143	HDHDB.....	138	TB6214.....	144
36CB.....	143	IB.....	145	TB6216.....	144
36DO.....	143	JP-06.....	141	TB6218.....	144
36SL.....	141	JP-09.....	141	TC.....	129
3F.....	125	JP-12.....	141	TT.....	127
3I.....	135	JP-120.....	141	VH.....	138
30.....	135	JP-18.....	141	VT.....	136
4F.....	124	JP-24.....	141		
4I.....	134	JP-30.....	141		
40.....	134	JP-36.....	141		
5003-1.....	140	LH.....	130		
5003-2-S1.....	140	LY.....	131		
5009-1.....	140	NF.....	140		
5009-2-S1.....	140	NFHA.....	140		
50172.....	145	NL.....	140		
6F.....	123	NLHA.....	140		
6I.....	133	OB.....	145		
60.....	133	OT.....	136		
8-9053.....	139	PC.....	142		
9036-31.....	147	PF.....	141		

I-BEAM - KEYWORD INDEX

Description.....	Page	Description.....	Page
30° Horizontal Elbow [3F]	125	Horizontal Tapped Cross [TC]	129
30° Vertical Elbow Inside [3I]	135	Horizontal Tapped Tee [TT]	127
30° Vertical Elbow Outside [3O]	135	Horizontal Tee [FT]	125
45° "Y" Branch Left Hand [LY]	131	How to Order	120
45° "Y" Branch Right Hand [RY]	131	I-Beam™ Fittings	121
45° Horizontal Elbow [4F]	124	Isolation Pad [9131-IP]	139
45° Vertical Elbow Inside [4I]	134	Joint Plate	141
45° Vertical Elbow Outside [4O]	134	Left Hand Reducer [LH]	130
60° Horizontal Elbow [6F]	123	Material / Finish	140
60° Vertical Elbow Inside [6I]	133	Mid-Span Splice Plate [RC]	137
60° Vertical Elbow Outside [6O]	133	Mustang Universal One-Piece Pipe, Conduit (GRC, EMT & IMC) and Tubing Clamps [PS MUJ]	144
90° Horizontal Elbow [9F]	122	Nylon Barrier Splice & Protector [BSP-L]	145
90° Vertical Cable Support Elbow [SR]	136	Ordering Information	120
90° Vertical Elbow Inside [9I]	132	Peak Cover Connector [PC]	142
90° Vertical Elbow Outside [9O]	132	Peak Pitch Cover Connector [PP]	142
Barrier Strip - Horizontal Fitting [FB]	145	Power-Pier Rooftop Support System	147
Barrier Strip Clamp (Optional) [50172]	145	Reducing Connector [CO]	137
Barrier Strip Vertical Elbow Outside [OB] & Inside [IB]	145	Right Hand Reducer [RH]	130
Barrier Strips	145	Rod Coupler [PS 135]	140
Blind End [BE]	143	Selection Chart	118-119
Bonding Jumper [CBJ]	143	Single Rod Hanger Support	148
Box Connector [CB]	143	Specification Aluminum Cope I-Beam System	149
Box Splice Plate [CA]	139	Split-Lock Washers [PS 211]	140
Cable Tray Ground Clamp [9156]	143	Square Nuts [PS 6108]	140
Channel-Type Supports	146	Standard Duty	146
Combination Hold-Down / Expansion Guide [9053]	139	Straight Length	120
Combination Hold-Down Clamp & Expansion Guide [9131A]	139	Straight Reducer [ST]	130
Conduit Clamp Bracket [CCB]	144	Structural Support Bracket	147
Conduit-to-Cable Tray Clamp Swivel Type [TB]	144	Support Brackets & Tray Hangers	147
Connector Hardware	140	Supports	146
Connector Plates	137-138	Trapeze Hanger Support	148
Continuous Threaded Rod [PS 146]	140	Tray Connectors	137
Cover Accessories	142	Tray Hanger & Supports	148
Cover Screw [EM]	140	Typical Specifications	149
Covers	141	Universal Aluminum Barrier Strip - Straight Section [SB]	145
Cross Connection Bracket [CCB]	138	Universal Connector [RC]	137
Double Channel-Type Supports	146	Vertical Adj. Branch Pivot Connector [BPC]	138
Double Clamp Connector [DC]	142	Vertical Adjustable Connector [CV]	138
Drop Out [DO]	143	Vertical Hanger Splice Plate [VH]	138
Electrical Grounding Chart	149	Vertical Tee - Down [VT]	136
Electro-Galv. Steel Cover Clip [PS 135X]	142	Vertical Tee - UP [OT]	136
Elevated Cover Connectors [EM-CC]	142	Vertical Tee Down [VT] & Up [OT]	136
Expansion Connector [CE]	137	Wall Penetrating Sleeve Assembly	144
Fender Washers [PS 230]	140	Wall Support Brackets.....	147
Flat Washers [PS 209]	140		
Ground Cable Retainer Clamp	143		
Gusset-Type Supports	146		
Hardware	140		
Heavy Duty	146		
Heavy Duty Hold Down Bracket [HDHDB]	138		
Hex Head Cap Screw / Round Head, Slotted Cap Screw [PS 6024]	140		
Hex Nuts [PS 83]	140		
Hold-Down [9132]	139		
Horizontal Adjustable Connector [CH]	137		
Horizontal Cross [FC]	128		

HAT - PART NUMBER INDEX

Part Number.....	Page	Part Number.....	Page	Part Number.....	Page
50172.....	106	60.....	71	FT.....	64
[W] DC.....	125	9025-98.....	108	HS.....	102
01CC.....	103	9036-31.....	109	HV.....	102
01-CC.....	103	9036-37.....	109	IB.....	106
01CO.....	100	9036-45.....	109	JP-06.....	102
01FB-06.....	106	9037-12.....	109	JP-09.....	102
01SB-12.....	106	9037-18.....	109	JP-12.....	102
02CA.....	100	9037-24.....	109	JP-120.....	102
02CE.....	100	9037-30.....	109	JP-18.....	102
02CH.....	100	9037-36.....	109	JP-24.....	102
02CV.....	100	9037-42.....	109	JP-30.....	102
02RC.....	100	9039.....	107	JP-36.....	102
03CO.....	100	9040.....	107	LH.....	69
04CO.....	100	9041.....	107	LY.....	70
06BE.....	104	9042.....	107	NF.....	102
06CB.....	104	9043.....	108	NL.....	102
06CO.....	100	9043-37.....	108	OB.....	106
06DO.....	104	9056-EP.....	104	PC.....	103
07CO.....	100	9056-SS.....	104	PF.....	102
09BE.....	106	9057-EP.....	104	PH.....	102
09CB.....	106	9057-SS.....	104	PS.....	102
09CO.....	100	9131-IP.....	107	PS 135.....	101
09DO.....	104	9132.....	107	PS 146.....	101
10CO.....	100	9133.....	107	PS 209.....	101
12BE.....	104	9156.....	104	PS 211.....	101
12CB.....	104	9F.....	62	PS 230.....	101
12CO.....	100	9I.....	71	PS 6024.....	101
12DO.....	104	90.....	71	PS 6072.....	101
13CO.....	100	AF.....	70	PS 6108.....	101
15CO.....	100	BE.....	104	PS 651.....	108
18BE.....	104	BSP.....	106	PS 809.....	108
18CB.....	104	BSP-L.....	106	PS 83.....	101
18CO.....	100	CA.....	100	PS 838R.....	108
18DO.....	104	CB.....	104	PV.....	102
21CO.....	100	CBJ.....	104	RC.....	100
24BE.....	104	CBJ-250C.....	104	RH.....	69
24CB.....	104	CBJ-4C.....	104	RY.....	70
24CO.....	100	CBJ-C.....	104	SB.....	106
24DO.....	104	CC.....	103	SL.....	61
27CO.....	100	CCB-050.....	105	SR.....	73
30BE.....	104	CCB-075.....	105	ST.....	69
30CB.....	104	CCB-100.....	105	T200E.....	110
30CO.....	100	CCB-125.....	105	T201E.....	110
30DO.....	104	CCB-150.....	105	TB6209.....	105
36BE.....	104	CCB-175.....	105	TB6210.....	105
36CB.....	104	CCB-200.....	105	TB6211.....	105
36DO.....	104	CE.....	100	TB6214.....	105
3F.....	63	CH.....	100	TB6216.....	105
3I.....	72	CO.....	100	TB6218.....	105
3O.....	72	CV.....	100	TC.....	67-68
4F.....	63	DC.....	103	TT.....	66
4I.....	72	DO.....	104	VC.....	103
4O.....	72	EM.....	103	VT.....	73
5003.....	101	EM-CC.....	103		
5003-1.....	101	EM-CC-SS.....	103		
5009-1.....	101	FB.....	106		
50172.....	106	FC.....	65		
6F.....	62	FL.....	102		
6I.....	71	FS.....	102		

HAT - KEYWORD INDEX

Description.....	Page	Description.....	Page
30° Horizontal Elbow [3F]	63	Horizontal Tee [FT]	64
30° Vertical Elbow Inside [3I]	72	INSIDE (3I)	72
30° Vertical Elbow Outside [3O]	72	INSIDE (4I)	72
45° "Y" Branch Left [LY]	70	INSIDE (6I)	71
45° "Y" Branch Right [RY]	70	INSIDE (9I)	71
45° Horizontal Elbow [4F]	63	Isolation Pad [9131-IP]	107
45° Vertical Elbow Inside [4I]	72	Joint Plate	102
45° Vertical Elbow Outside [4O]	72	Left Hand Reducer (LH)	69
60° Horizontal Elbow [6F]	62	Nylon Barrier Splice & Protector [BSP-L]	106
60° Vertical Elbow Inside [6I]	71	Ordering information	60
60° Vertical Elbow Outside [6O]	71	OUTSIDE (3O)	72
90° Angle Connectors [CA]	100	OUTSIDE (4O)	72
90° Horizontal Elbow [9F]	62	OUTSIDE (6O)	71
90° Vertical Cable Support Elbow (SR)	73	OUTSIDE (9O)	71
90° Vertical Elbow Inside [9I]	71	Overview	58-59
90° Vertical Elbow Outside [9O]	71	Peak Cover Connector [PC, VC]	103
Adjustable Elbow [AF]	70	Reducing Connector [CO]	100
Barrier Strip Clamp (Optional) [50172]	106	Right Hand Reducer (RH)	69
Barrier Strip Vertical Elbow Inside [IB]	106	Rod Coupler [PS 135]	101
Barrier Strip Vertical Elbow Outside [OB]	106	Round Head, Slotted Cap Screw [PS 6072]	101
Barrier Strip—Horizontal Fitting [FB]	106	Selection Chart	54-57
Barrier Strips	106	Single Rod Hanger Support	109
Barrier Strip—Straight Section [SB]	106	Single Side Connector [01-CC]	103
Blind End [BE]	104	Slotted Rungs	58
Bonding Jumper [CBJ]	104	Solid Rungs	58
Box Connector [CB]	104	Split-Lock Washers [PS 211]	101
Cable Tray Ground Clamp [9156]	104	Square Nuts [PS 6108]	101
Channel-Type Supports	108	Straight Length [SL]	61
Conduit Clamp Bracket	105	Straight Reducer [ST]	69
Conduit-to-Cable Tray Clamp	105	Structural Support Bracket	108
Conduit-to-Cable Tray Clamp - Swivel Type	105	Support Brackets	108
Connector Hardware [5003]	101	Trapeze Hanger Support	110
Connector Plates	100	Tray Connectors	100
Continuous Threaded Rod [PS 146]	101	Tray Hanger & Supports	110
Cover Accessories	103	Universal Aluminum Barrier Strip - Straight Section [SB]	106
Cover Connector [CC]	103	Universal Curvilinear Connectors [RC]	100
Cover Screw [EM]	101	Vertical Adjustable Connectors [CV]	100
Covers	102	Vertical Tee - Down (VT)	73
Double Clamp Connector (W) DC]	103	Vertical Tee - Up (OT)	73
Drop Out [DO]	104	Wall Penetrating Sleeve Assembly [SS89042(W)*]	105
Elevated Cover Connectors [EM-CC]	103	Wall Support Brackets.....	109
Expansion Connectors [CE]	100		
Fender Washers [PS 230]	101		
Flat Washers [PS 209]	101		
Ground Cable Retainer Clamp	104		
Gusset-Type Supports	108		
Hardware	101		
Hex Head Cap Screw [PS 6024]	101		
Hex Nuts [PS 83]	101		
Hold-Down [9132]	107		
Hold-Down Clamp & Expansion Guide	107		
Horizontal Adjustable Connectors [CH]	100		
Horizontal Cross [FC]	65		
Horizontal Tapped Cross [TC]	67-68		
Horizontal Tapped Tee [TT]	66		

TROF - PART NUMBER INDEX

Part Number.....	Page	Part Number.....	Page	Part Number.....	Page
01CC	103	9036-37	109	IB	106
01CO	100	9036-45	109	JP-06	102
01FB-06	106	9037-12	109	JP-09	102
01SB-12	106	9037-18	109	JP-12	102
02CA	100	9037-24	109	JP-120	102
02CE	100	9037-30	109	JP-18	102
02CH	100	9037-36	109	JP-24	102
02CV	100	9037-42	109	JP-30	102
02RC	100	9039	107	JP-36	102
03CO	100	9040.....	107	LH	94
04CO	100	9041.....	107	LY	95
06BE	104	9042.....	107	NF	102
06CB	104	9043.....	108	NL	102
06CO	100	9043-37	108	OB	106
06DO	104	9056-EP	104	OT	98
07CO	100	9056-SS	104	PC	103
09BE	104	9057-EP	104	PF	102
09CB	104	9057-SS	104	PH	102
09CO	100	9131-IP	107	PS	102
09DO	104	9132.....	107	PS 135	101
10CO	100	9133.....	107	PS 146	101
12BE	104	9156.....	104	PS 209	101
12CB	104	9F	87	PS 211	101
12CO	100	9I	96	PS 230	101
12DO	104	90	96	PS 6024	101
13CO	100	AF	95	PS 6072	101
15CO	100	BE	104	PS 6108	101
18BE	104	BSP	106	PS 651	108
18CB	104	BSP-L	106	PS 809	108
18CO	100	CA	100	PS 83	101
18DO	104	CB	104	PS 838R-10	109
21CO	100	CBJ	104	PS 838R-12	109
24BE	104	CBJ-250C	104	PS 838R-16	109
24CB	104	CBJ-4C	104	PS 838R-18	109
24CO	100	CBJ-C	104	PS 838R-24	109
24DO	104	CC	103	PS 838R-30	109
27CO	100	CCB-050.....	105	PS 838R-6	109
30BE	104	CCB-075.....	105	PS 838R-8	108
30CB	104	CCB-100.....	105	PV	102
30CO	100	CCB-125.....	105	RC	100
30DO	104	CCB-150.....	105	RH	94
36BE	104	CCB-175.....	105	RY	95
36CB	104	CCB-200.....	105	SB	106
36DO	100	CE	100	SL	86
3F	88	CH	100	SR	98
3I	97	CO	100	ST	94
30	97	CV	100	TC	92-93
4F	88	DC	103	TT	90-91
4I	97	DO	104	T200E.....	110
40	97	DOG-1	158	T201E.....	110
5003.....	101	EM	103	TB6209	105
5003-1	101	EM-CC	103	TB6210	105
5009.....	101	EM-CC-SS	103	TB6211	105
5009-1	101	FB	106	TB6214	105
50172.....	106	FC	89	TB6216	105
6F	87	FL	102	TB6218	105
6I	96	FS	102	VT	98
60	96	FT	89		
9025-98	108	HS	102		
9036-31	109	HV	102		

TROF - KEYWORD INDEX

Description.....	Page	Description.....	Page
30° Horizontal Elbow [3F]	88	Horizontal Tee [FT]	89
30° Vertical Elbow Inside [3I]	97	How to Order	84-85
30° Vertical Elbow Outside [3O]	97	Inside [3I]	97
45° “Y” Branch Left [LY]	95	Inside [4I]	97
45° “Y” Branch Right [RY]	95	Inside [6I]	96
45° Horizontal Elbow [4F]	88	Inside [9I]	96
45° Vertical Elbow Inside [4I]	97	Isolation Pad [9131-IP]	107
45° Vertical Elbow Outside [4O]	97	Joint Plate	102
60° Horizontal Elbow [6F]	87	Left Hand Reducer [LH]	94
60° Vertical Elbow Inside [6I]	96	Nylon Barrier Splice & Protector [BSP-L]	106
60° Vertical Elbow Outside [6O]	96	Nylon Dropout Grommet [DOG-1]	158
90° Angle Connector [CA]	100	Ordering Information	83
90° Horizontal Elbow [9F]	87	Outside [30]	97
90° Vertical Cable Support Elbow [SR]	98	Outside [40]	97
90° Vertical Elbow Inside [9I]	96	Outside [60]	96
90° Vertical Elbow Outside [9O]	96	Outside [90]	96
Adjustable Elbow [AF]	95	Overview	82
Barrier Strip - Horizontal Fitting [FB]	106	Peak Cover Connector [PC, VC]	102
Barrier Strip - Straight Section [SB]	106	Reducing Connector [CO]	100
Barrier Strip Clamp [50172] (optional)	106	Right Hand Reducer [RH]	94
Barrier Strip Vertical Elbow Inside [IB]	106	Rod Coupler [PS 135]	101
Barrier Strip Vertical Elbow Outside [OB]	106	Round Head, Slotted Cap Screw [PS 6072]	101
Barrier Strips	106	Seismic Hold-Down [9132]	107
Blind End [BE]	104	Selection Chart:	83-86
Bonding Jumper [CBJ]	104	Single Rod Hanger Support	109
Box Connector [CB]	104	Single Side Connector [01CC]	103
Cable Tray Ground Clamp [9156]	104	Split-Lock Washers [PS 211]	101
Channel-Type Supports	108	Square Nuts [PS 6108]	101
Conduit Clamp Bracket	105	Straight Length [SL]	86
Conduit-to-Cable Tray Clamp	105	Straight Reducer [ST]	94
Connector Hardware Bolt [5003]	101	Structural Support Bracket	109
Connector Hardware Nut [5009]	101	Support Brackets	108
Connectors	100	Trapeze Hanger Support	110
Continuous Threaded Rod [PS 146]	101	Tray Connectors	100
Cope CSA Standards C22-2 Cable Trof Ventilated & Solid Bottom Type	84	Tray Hanger & Supports	109
Cover Accessories	103	Universal Aluminum Barrier Strip - Straight Section [SB]	106
Cover Connector [CC]	103	Universal Curvilinear Connector [RC]	100
Cover Screw [EM]	101	Vertical Adjustable Connectors [CV]	100
Covers	102	Vertical Supports	108
CSA Ordering Information	84	Vertical Tee - DOWN (VT)	98
CSA System Selection Chart:	85	Vertical Tee - UP (OT)	98
Double Clamp Connector (W) DC]	103	Wall Penetrating Sleeve Assembly [SS89042W*]	105
Drop Out [DO]	104	Wall Support Brackets.....	109
Electrical Grounding Chart	48		
Elevated Cover Connectors [EM-CC]	103		
Expansion Connector [CE]	100		
Fender Washers [PS 230]	101		
Flat Washers [PS 209]	101		
Ground Cable Retainer Clamp	104		
Gusset-Type Supports	108		
Hardware	101		
Hex Head Cap Screw [PS 6024]	101		
Hex Nuts [PS 83]	101		
Hold-Down Clamp & Expansion Guide	107		
Horizontal Adjustable Connectors [CH]	100		
Horizontal Cross [FC]	89		
Horizontal Tapped Cross [TC]	92-93		
Horizontal Tapped Tee [TT]	90-91		

CHANNEL - PART NUMBER & KEYWORD INDEX

Part Number.....	Page.....	Description.....	Page.....
50174.....	161	30° Horizontal Elbow [3F]	156
70620.....	161	30° Vertical Inside Elbow [3I]	158
03BE	160	30° Vertical Outside Elbow [3O]	158
03CB	160	45° Horizontal Elbow [4F]	155
03CC	161	45° Vertical Inside Elbow [4I]	157
03CE	160	45° Vertical Outside Elbow [4O]	158
03CH	161	60° Horizontal Elbow [6F]	155
03CS	160	60° Vertical Inside Elbow [6I]	157
03CV	161	60° Vertical Outside Elbow [6O]	157
03DO	160	90° Horizontal Elbow [9F]	155
04BE	160	90° Vertical Inside Elbow [9I]	156
04CB	160	90° Vertical Outside Elbow [9O]	156
04CC	161	Accessories	160 - 161
04CE	160	Adjustable Horizontal Connector [CH]	161
04CH	161	Adjustable Riser Connector [CV]	161
04CS	160	Blind End [BE]	160
04CV	161	Channel Hangers	162
04DO	160	Channel Holddown Clamp (Stainless Steel) [9079]	161
06BE	160	Channel to Box or Wall Connector [CB]	160
06CB	160	Cope Channel	154
06CC	161	Cover Connector [CC]	161
06CE	160	End Dropout [DO]	160
06CH	161	Expansion Connector [CE]	160
06CS	160	Fittings	155 - 157
06CV	161	Hangers	162
06DO	160	Horizontal Cross [FC]	159
3F	156	Horizontal Tee [FT]	159
3I	158	Interconnections	161
3O	158	Introduction	154
4F	155	Nylon Dropout Grommet [DOG-1]	160
4I	157	Ordering	154
4O	158	Standard Connector [CS]	160
6F	155		
6I	157		
6O	157		
9013.....	162		
9013-1.....	162		
9014.....	162		
9014-1.....	162		
9019-1.....	160		
9019-2.....	160		
9079.....	160		
9F	155		
9I	156		
9O	156		
BE	160		
CB	160		
CC	161		
CE	160		
CH	161		
CS	160		
CV	161		
DO	160		
DOG-1	160		
FC	159		
FT	159		

COPE-GLAS™ - PART NUMBER INDEX

Part Number.....	Page	Part Number.....	Page	Part Number.....	Page
200-3827 thru 200-3843	197	375PU-150	198	BE181220	180
20P-1000	197	375PU-200	198	BE240610	180
20P-1200	197	375PU-250	198	BE240620	180
20P-2000	197	375PU-300	198	BE240910	180
20P-2100	197	375PU-CN	198	BE240920	180
20P-2200	197	375PU-CNJHD	198	BE241210	180
20P-2500	199	375PU-FN-000	197	BE241220	180
20P-2502	199	45H	187	BE300610	180
20P-2504	199	500PLJ-CN	198	BE300620	180
20P-2506	199	500PU-125	198	BE300910	180
20P-2508	199	500PU-200	195, 198	BE300920	180
20P-2510	199	500PU-250	198	BE301210	180
20P-2512	199	500PU-300	198	BE301220	180
20P-2514	199	500PU-CN	195	BE360610	180
20P-2516	199	500PU-CNHD	198	BE360620	180
20P-2518	199	500PU-FN-000	197	BE360910	180
20P-2520	199	50PU-2008	200	BE360920	180
20P-2522	199	50PU-2045	200	BE361210	180
20P-2524	199	50PU-2090	200	BE361220	180
20P-2526	199	50PU-2538	200	CC1	195
20P-2528	200	50PU-2611	200	CCE	195
20P-2530	200	50PU-2611-SP	200	CCE06 thru CCE36	195
20P-2534	200	50PU-2613	200	CE	181
20P-2540	200	50PU-2616	197	CE060610	181
20P-2542	200	50PU-2636	200	CE060620	181
20PU-5853	200	50PU-2636A	200	CE060910	181
20PU-5855	200	50PU-2636B	200	CE060920	181
20PU-5903	200	50PU-2936	200	CE061210	181
20PU-5905	200	625PU-FN-000	197	CE061220	181
20V-1000	197	750PU-FN-000	197	CE061810	181
20V-1200	197	90H	187	CE061820	181
20V-2000	197	ADC1	195	CE090610	181
20V-2100	197	AES1	196	CE090620	181
20V-2200	197	AES3	196	CE090910	181
20V-2500	199	BE	180	CE090920	181
20V-2502	199	BE060610	180	CE091210	181
20V-2504	199	BE060620	180	CE091220	181
20V-2506	199	BE060910	180	CE091810	181
20V-2508	199	BE060920	180	CE091820	181
20V-2510	199	BE061210	180	CE120610	181
20V-2512	199	BE061220	180	CE120620	181
20V-2514	199	BE090610	180	CE120910	181
20V-2516	199	BE090620	180	CE120920	181
20V-2518	199	BE090910	180	CE121210	181
20V-2520	199	BE090920	180	CE121220	181
20V-2522	199	BE091210	180	CE121810	181
20V-2524	199	BE091220	180	CE121820	181
20V-2526	199	BE120610	180	CE180610	181
20V-2528	200	BE120620	180	CE180620	181
20V-2530	200	BE120910	180	CE180910	181
20V-2534	200	BE120920	180	CE180920	181
20V-2540	200	BE121210	180	CE181210	181
20V-2542	200	BE121220	180	CE181220	181
252075.....	204	BE180610	180	CE181810	181
300PU-100	198	BE180620	180	CE181820	181
300PU-125	198	BE180910	180	CE240610	181
300PU-150	198	BE180920	180	CE240620	181
375PU-125	198	BE181210	180	CE240910	181

COPE-GLAS™ - PART NUMBER INDEX (CONT.)

Part Number	Page	Part Number	Page	Part Number	Page
CE240920	181	CTB36A	196	CZ300910	181
CE241210	181	CTC06, CTC06V	182	CZ300920	181
CE241220	181	CTC09, CTC09V	182	CZ301210	181
CE241810	181	CTC12, CTC12V	182	CZ301220	181
CE241820	181	CTC18, CTC18V	182	CZ301810	181
CE300610	181	CTC24, CTC24V	182	CZ301820	181
CE300620	181	CTC30, CTC30V	182	CZ360610	181
CE300910	181	CTC36, CTC36V	182	CZ360620	181
CE300920	181	CTCE06, CTCE06V	182	CZ360910	181
CE301210	181	CTCE09, CTCE09V	182	CZ360920	181
CE301220	181	CTCE12, CTCE12V	182	CZ361210	181
CE301810	181	CTCE18, CTCE18V	182	CZ361220	181
CE301820	181	CTCE24, CTCE24V	182	CZ361810	181
CE360610	181	CTCE30, CTCE30V	182	CZ361820	181
CE360620	181	CTCE36, CTCE36V	182	CZD	181
CE360910	181	CZ	181	CZD060610	181
CE360920	181	CZ060610	181	CZD060620	181
CE361210	181	CZ060620	181	CZD060910	181
CE361220	181	CZ060910	181	CZD060920	181
CE361810	181	CZ060920	181	CZD061210	181
CE361820	181	CZ061210	181	CZD061220	181
CG-CCB-050 thru CG-CCB-400	196	CZ061220	181	CZD061810	181
CH	202	CZ061810	181	CZD061820	181
CH2-10	202	CZ061820	181	CZD090610	181
CH2-SP	204	CZ090610	181	CZD090620	181
CH2-SPH22	204	CZ090620	181	CZD090910	181
CH2-SPH45	204	CZ090910	181	CZD090920	181
CH2-SPH90	204	CZ090920	181	CZD091210	181
CH2-SPV22	204	CZ091210	181	CZD091220	181
CH2-SPV45	204	CZ091220	181	CZD091810	181
CH2-SPV90	204	CZ091810	181	CZD091820	181
CH3-10	200	CZ091820	181	CZD120610	181
CH3-10P	200	CZ120610	181	CZD120620	181
CH3-SP	204	CZ120620	181	CZD120910	181
CH3-SPH22, CH3-SPH45, CH3-SPH90	204	CZ120910	181	CZD120920	181
CH3-SPV22, CH3-SPV45, CH3-SPV90	204	CZ120920	181	CZD121210	181
CH4-10, CH4-10P	202	CZ121210	181	CZD121220	181
CH4-HB90-24	202	CZ121220	181	CZD121810	181
CH4-HT	203	CZ121810	181	CZD121820	181
CH4-SP	204	CZ121820	181	CZD180610	181
CH4-SPH22, CH4-SPH45, CH4-SPH90	204	CZ180610	181	CZD180620	181
CH4-SPV22, CH4-SPV45, CH4-SPV90	204	CZ180620	181	CZD180910	181
CH4-VI90-24, CH4-VO90-24	203	CZ180910	181	CZD180920	181
CH4-X	203	CZ180920	181	CZD181210	181
CH6-10, CH6-10P	202	CZ181210	181	CZD181220	181
CH6-SP	204	CZ181220	181	CZD181810	181
CH6-SPH22, CH6-SPH45, CH6-SPH90	204	CZ181810	181	CZD181820	181
CH6-SPV22, CH6-SPV45, CH6-SPV90	204	CZ181820	181	CZD240610	181
CH8-10, CH8-10P	202	CZ240610	181	CZD240620	181
CH8-SP	204	CZ240620	181	CZD240910	181
CH8-SPH22, CH8-SPH45, CH8-SPH90	204	CZ240910	181	CZD240920	181
CH8-SPV22, CH8-SPV45, CH8-SPV90	204	CZ240920	181	CZD241210	181
CTB06A	196	CZ241210	181	CZD241220	181
CTB09A	196	CZ241220	181	CZD241810	181
CTB12A	196	CZ241810	181	CZD241820	181
CTB18A	196	CZ241820	181	CZD300610	181
CTB24A	196	CZ300610	181	CZD300620	181
CTB30A	196	CZ300620	181	CZD300910	181

COPE-GLAS™ - PART NUMBER INDEX (CONT.)

Part Number.....	Page	Part Number.....	Page	Part Number.....	Page
CZD300920	181	LC241210	180	RR2406	191
CZD301210	181	LC241212	180	RR2409	191
CZD301220	181	LC300610	180	RR2412	191
CZD301810	181	LC300612	180	RR2418	191
CZD301820	181	LC300910	180	RR3006	191
CZD360610	181	LC300912	180	RR3009	191
CZD360620	181	LC301210	180	RR3012	191
CZD360910	181	LC301212	180	RR3018	191
CZD360920	181	LC360610	180	RR3024	191
CZD361210	181	LC360612	180	RR3606	191
CZD361220	181	LC360910	180	RR3609	191
CZD361810	181	LC360912	180	RR3612	191
CZD361820	181	LC361210	180	RR3618	191
D006 thru D036	196	LC361212	180	RR3624	191
EPD06 thru EPD36	195	LES12	193	RR3630	191
EPE06 thru EPE36	195	LF400	195	RS	191
EPL06 thru EPL36	195	LH12	194	RS0906	191
EPZ07 thru EPZ36	195	LH22.5, LH45, LH90	193	RS1206	191
ES12	193	LS12	193	RS1209	191
F400	195	LV12, LV22.5, LV45, LV90	194	RS1806	191
FECNBSS	194	MONBW2	194	RS1809	191
H12	194	NDR1	195	RS1812	191
H22.5, H45, H90	193	PCR-050 hru PCR-600	198	RS2406	191
HAB	188	PTK06 thru PTK36	182	RS2409	191
HB	202	PTKE06 thru PTKE36	182	RS2412	191
HD4AB	195	RGBC-1 thru RGBC-3	198	RS2418	191
HDBLTNT	195	RGBS3 thru RGBS6	195	RS3006	191
HT	203	RGFH1	196	RS3009	191
LADC1	195	RGFH2	196	RS3012	191
LC	180	RL	191	RS3018	191
LC060610	180	RL0906	191	RS3024	191
LC060612	180	RL1206	191	RS3606	191
LC060910	180	RL1209	191	RS3609	191
LC060912	180	RL1806	191	RS3612	191
LC061210	180	RL1809	191	RS3618	191
LC061212	180	RL1812	191	RS3624	191
LC090610	180	RL2406	191	RS3630	191
LC090612	180	RL2409	191	S0200	196
LC090910	180	RL2412	191	S12	193
LC090912	180	RL2418	191	S12-MID	193
LC091210	180	RL3006	191	SBNBW2	194
LC091212	180	RL3009	191	SP	204
LC120610	180	RL3012	191	SPH	204
LC120612	180	RL3018	191	SPV	204
LC120910	180	RL3024	191	SSNBW2-316	194
LC120912	180	RL3606	191	T	189
LC121210	180	RL3609	191	UB-050 thru UB-400	198
LC121212	180	RL3612	191	V12, V22.5, V45	194
LC180610	180	RL3618	191	V45I, V45O	184
LC180612	180	RL3624	191	V90	194
LC180910	180	RL3630	191	V90I, V90O	183
LC180912	180	RR	191	VAB	185
LC181210	180	RR0906	191	VI, VO	203
LC181212	180	RR1206	191	VT	186
LC240610	180	RR1209	191	WR375 thru WR750	187
LC240612	180	RR1806	191	X	190, 203
LC240910	180	RR1809	191		
LC240912	180	RR1812	191		

COPE-GLAS™ - KEYWORD INDEX

Description.....	Page
0° thru 90° Vertical Adjustable Bends [VAB]	185
45° Horizontal Bends [45H]	187
45° Vertical Inside Bends [V45I]	184
45° Vertical Outside Bends [V45O]	184
90° Horizontal Bends [90H]	187
90° Vertical Inside Bends [V90I]	183
90° Vertical Outside Bends [V90O]	183
Accessories	196
Additional Related Products	204
Adjustable Divider Clamp	195
Adjustable Horizontal Splice Plates	194
Adjustable Vertical Splice Plates	194
Advantages of COPE-GLAS™ Cable Tray	166 - 167
AickinstrutR Channel	197
AickinstrutR Channel Nuts	198
AickinstrutR Non-Metallic Strut Support Systems, Fasteners and Structural Shapes.	204
AickinstrutR Rod Couplers	197
AickinstrutR Support Systems	197 - 200
All-Thread Hex Flange Nuts	197
All-Thread Washers	197
Application Environments	172 - 173
Barrier Strip	195
Cable Tray Hardware	194
Channel Capping Strip	197
Channel Fittings [CH]	201
Channel Splice Plate Hardware	203
Channel Splice Plates	203
Conduit to Cable Tray Clamp	196
Construction and Physical Properties	170 - 171
Cope® Metallic Cable Tray Systems and Supports	204
COPE-GLAS Cable Tray Covers	182
Cover Clamp [CC1]	195
Cover Clamp [CCE]	195
Cover Stand-Offs	196
Covers	182
Drop Outs	196
End Plates	195
Expansion Splice Plates	193
Fiberfast Bolts	198
Fiberglass All-Thread Rod	197
Fiberglass Bolt	195
Fiberglass Channel	201 - 204
Fittings	182 - 192
Fittings / Splice Plates	192
Fixed Angle Horizontal Splice Plates	193
Fixed Angle Vertical Splice Plates	194
Floor & Panel Flange	195
Hanger Rod Beam Clamps	198
Hold Down Package	195
Horizontal Adjustable Bends [HAB]	188
Horizontal Cross [X]	202
Horizontal Crossovers [X]	190
Horizontal Elbow Splice Plates [SPH]	203
Horizontal Elbows [HB]	201
Horizontal Tee [HT]	202

Description.....	Page
Horizontal Tees [T]	189
Inside Vertical Elbow [VI]	202
Installation Procedures	175 - 180
K. Rigid Pipe Clamps	198
Left Reducers	191
Non-Metallic U-Bolts	198
Outside Vertical Elbow [VO]	202
Right & Left Reducers [RR] or [RL]	191
Right Reducers	191
Rivet [NDR1]	195
Selection Guide	174
Specifications	169
Splice Plates	192 - 193
Splice Plates & Hardware	194
Standards	168
Straight Reducers	191
Straight Reducers [RS]	191
Straight Sections	180 - 181
Straight Splice Plates	193
Straight Splice Plates [SP]	203
Structural Designs	174
Tray Covers and Accessories	195
Tray Flange Hanger	196
Type BE Straight Section - E Profile [BE]	180
Type CE Straight Section - E Profile [CE]	181
Type CZ Straight Section - Z Profile [CZ]	181
Type CZD Straight Section - Deep Z Profile [CZD]	181
Type LC Straight Section - C Profile* [LC]	180
Vertical Elbow Splice Plates [SPV]	203
Vertical Tees [VT]	186
Wall Support Brackets	196
Marine Rung	196

WIRE BASKET TRAY - PART NUMBER INDEX

Part Number	Page	Part Number	Page	Part Number	Page
BOTTOM-CLIP	214, 235, 237	CAT6-16SL-120	212	CAT-PED-12	224
CAT(H)-(W)BE	227	CAT6-18BE	226	CAT-PED-KIT	224
CAT(H)-(W)CB	227	CAT6-18SL-120	212	CAT-PPA-(H)	218
CAT(H)-(W)WS	227	CAT6-20BE	226	CAT-PPA-06	218
CAT-(W)DO	225	CAT6-20SL-120	212	CAT-PPA-10	218
CAT-1x6-HC	217	CAT6-24BE	226	CAT-PPA-14	218
CAT2-(W)SL-120	210	CAT6-24SL-120	212	CAT-PPA-18	218
CAT2-01SB-120	225	CAT-AB-HSB	222	CAT-PPA-22	218
CAT2-02SL-120	210	CAT-AB-USB	222	CAT-PPA-26	218
CAT2-04	229	CAT-CB-HSB	223	CAT-SIDE-HC	217
CAT2-04BE	226	CAT-CB-MSB	223	CAT-UNI-DO	225
CAT2-04SL-120	210	CAT-CB-USB	221	CAT-USB-120	216
CAT2-06	229	CAT-CCA-(W)	218	CAT-USB-120	222
CAT2-06BE	226	CAT-CCA-04	218	CAT-WC-2	220
CAT2-06SL-120	210	CAT-CCA-06	218	CAT-ZBAR-120	219
CAT2-08	229	CAT-CCA-08	218	CH1	214
CAT2-08BE	226	CAT-CCA-12	218	CH2	214 - 215
CAT2-08SL-120	210	CAT-CCA-16	218	CH3	214 - 215
CAT2-12	229	CAT-CMA-(W)	223	EG-CBN	214, 215, 234
CAT2-12BE	226	CAT-CMA-04	223	PS 146	237
CAT2-12SL-120	210	CAT-CMA-06	223	PS 209	236
CAT2-16	229	CAT-CMA-08	223	PS 211	236
CAT2-16BE	226	CAT-CMA-12	223	PS 6024	236
CAT2-16SL-120	210	CAT-CPA-(W)	218	PS 6072	236
CAT2-18	229	CAT-CPA-06	218	PS 6108	236
CAT2-18BE	226	CAT-CPA-08	218	PS 619	237
CAT2-18SL-120	210	CAT-CPA-12	218	PS 651-(L)	221
CAT2-20	229	CAT-CPA-16	218	PS 809-(L)	221
CAT2-20BE	226	CAT-CUT	228	PS 83	236
CAT2-20SL-120	210	CAT-CVR-(W)	225	PSRS-1/2	237
CAT2-24	229	CAT-CVR-02	225	PSRS-1/4	237
CAT2-24BE	226	CAT-CVR-04	225	PSRS-3/8	237
CAT2-24SL-120	210	CAT-CVR-06	225	Short-Clip	214, 237
CAT-2x8-HC	217	CAT-CVR-08	225	SPLIT-BOLT	234
CAT4-(W)SL-120	211	CAT-CVR-12	225	T-BAR	213
CAT4-01SB-120	225	CAT-CVR-16	225	T-BAR-22	213
CAT4-04BE	226	CAT-CVR-18	225	Wide-Clip	214, 237
CAT4-04SL-120	211	CAT-CVR-20	225		
CAT4-08BE	226	CAT-CVR-24	225		
CAT4-08SL-120	211	CAT-EBC	227		
CAT4-12BE	226	CAT-GC	234		
CAT4-12SL-120	211	CAT-HGR-2	220		
CAT4-16BE	226	CAT-HGR-4	220		
CAT4-16SL-120	211	CAT-HLT	227		
CAT4-18BE	226	CAT-HSB-10	222, 223		
CAT4-18SL-120	211	CAT-HSB-120	216		
CAT4-20BE	226	CAT-HWSB-(W)	219		
CAT4-20SL-120	211	CAT-HWSB-08	219		
CAT4-24BE	226	CAT-HWSB-12	219		
CAT4-24SL-120	211	CAT-HWSB-18	219		
CAT6-(W)SL-120	212	CAT-HWSB-20	219		
CAT6-01SB-120	225	CAT-HWSB-24	219		
CAT6-06BE	226	CAT-MSB-10	222, 223		
CAT6-06SL-120	211	CAT-MSB-120	216		
CAT6-08BE	226	CAT-MWSB-(W)	219		
CAT6-08SL-120	211	CAT-MWSB-06	219		
CAT6-12BE	226	CAT-MWSB-08	219		
CAT6-12SL-120	211	CAT-MWSB-12	219		
CAT6-16BE	226	CAT-PED-06	224		

WIRE BASKET TRAY - KEYWORD INDEX

Description.....	Page	Description.....	Page
90° Bends - Cutting Diagrams	222 - 231	Hardware	235 - 237
90° Bends - Forming Instructions	230	Hex Head Cap Screws	236
90° Bends - Long Radius	229	Hex Nuts	236
90° Long Radius Bend	228 - 229	Lighting Bracket [CAT-HLT]	227
90° Short Radius Bend	228, 230	Lock Washers	236
Accessories	206 - 207, 225 - 227	Long & Short Radius Bends	207
Accessory Assembly	209	Offset	233
Assembly	209	Overview	208
Back-to-Back Channel Pendant [PS 809-(L)]	221	Pedestal Brackets	207, 224
Bar Connectors & Hardware	207	Pedestal Brackets [CAT-PED-06] & [CAT-PED-12]	224
Bend & Intersection Bars	213	Pedestal Kit [CAT-PED-KIT]	224
Blind End [CAT(H)-(W)BE]	226	Pendant [CAT-PPA-(H)]	218
Bottom Clip [BOTTOM-CLIP]	235	Pendants	207
Box Connector [CAT(H)-(W)CB]	226	Pictorial Index	207
Bracket [CAT-CMA-(W)]	223	Product Description	206
Cantilever & Zed Brackets	207	Quadruple Rod Reinforced Tray (6" Depth) [CAT6-(W)SL-120]	212
Cantilever & Zed Brackets	219	Reducer	233
Cantilever Medium [CAT-MWSB-(W)] & Heavy [CAT-HWSB-(W)]	219	Riser	233
Wire Basket Tray Assembly - CAT2, CAT4, & CAT6	209	Riser, Reducer & Offset Fittings	207, 233
Ceiling Clip [CAT-CCA-(W)]	218	Risers	228
Connector Hardware [EG-CBN]	215	Round Head Machine Screws	236
Connector Hardware Kits	215	Sample Specification	238
Connector Hardware Overview	214	Self-Splicing Straight Lengths	209
Connector Kit [CH1]	214	Single Channel Pendant [PS 651-(L)]	221
Connector Kit [CH2], [CH3]	215	Single Rod	216
Contents	206	Special Order Finishes	208
Cover [CAT-CVR-(W)]	225	Specification Information	206
Covers	206 - 207	Splice	213
Cross	232	Square Nuts	236
Cross & Tee Fittings	207, 232	Square Strut Washers	237
Cutting Tool [CAT-CUT]	228	Standard Bar Connector	213
Double Rod Reinforced Tray (2" Depth) [CAT2-(W)SL-120]	210	Standard Finish	208
Drop Out [CAT-(W)DO]	225	Standard Tee	232
Drop Rod Clip [CAT-1x6-HC], [CAT-2x8-HC], [CAT-SIDE-HC]	215	Straight Length	207
Drop Rod Clips	217	Strut Nuts	237
EG-CBN	214	Support Bracket Heavy [CAT-HSB-120]	216
Electrical Box Bracket [CAT-EBC]	227	Support Bracket Medium [CAT-MSB-120]	216
Fittings	206	Support Brackets	207
Fittings Overview	228	Tee and Cross	228
Flat Washers	236	Threaded Rod	237
General & Technical Information	206	Trapeze	216
Grounding	234	Tray Clips (See Page 233 for Connector Kits)	237
Grounding & Hardware	206 - 207	Tray Dividers [CAT2-01SB-120], [CAT4-01SB-120], & [CAT6-01SB-120]	226
Grounding Clamp/Split Bolt [SPLIT-BOLT]	234	Tray Dividers and Drop Outs	207
Grounding Clip [CAT-GC]	234	Triple Rod Reinforced Tray (4" Depth) [CAT4-(W)SL-120]	211
Hanger [CAT-HGR-2]	220	U Support Bracket [CAT-USB-120]	216
Hanger [CAT-HGR-4]	220	Wall & Ceiling Mounts	207, 218
Hangers	220	Wall Bracket [CAT-WC-2]	220
Hangers & Hanging Brackets	207	Wall Clip [CAT-CPA-(W)]	218
Hanging Bracket & Pendants	221	Wall Sleeve [CAT(H)-(W)WS]	227
Hanging Bracket [CAT-AB-HSB], [CAT-AB-USB]	222	ZED [CAT-ZBAR-120]	219
Hanging Bracket [CAT-CB-HSB]	223		
Hanging Bracket [CAT-CB-MSB]	222		
Hanging Bracket [CAT-CB-USB]	221		
Hanging Brackets	222 - 223		

NOTES

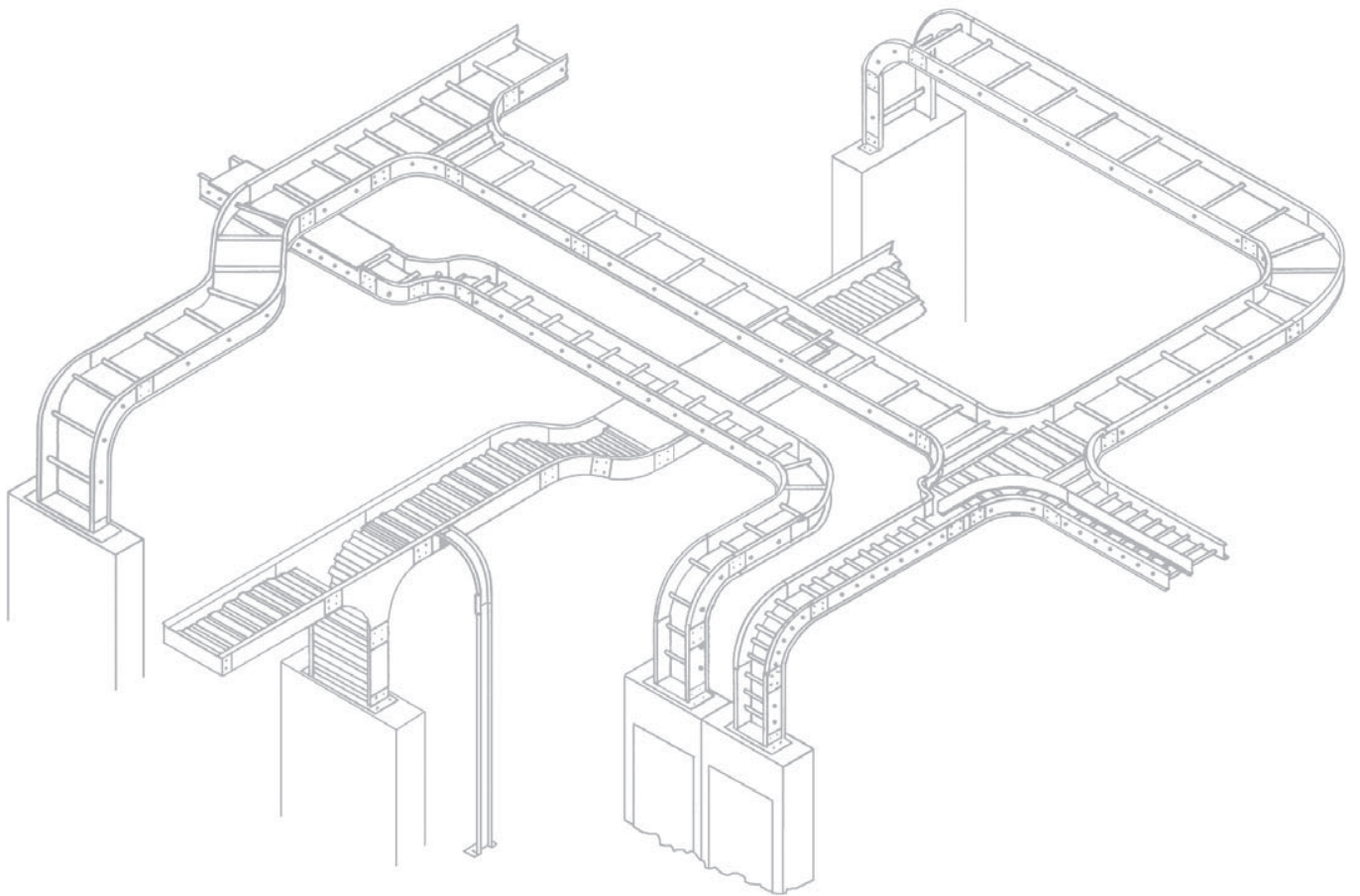

Cope® uses a unique manufacturing process called “cold swaging” to attach rung to rail. Compared to welded products, Cope cold swaged cable tray offers double the pull out strength, provide stiffer overall rigidity, freer access to cables and look better installed. This unique manufacturing process is extremely efficient which quickens production and improves product availability.

APPLICATION SPOTLIGHT: WIND TURBINES
Renewable Energy is a growing and important segment to the energy industry. The wind power industry is developing into an important player in that mix. Cope cold swaged cable tray has proven to be a vital component in the construction of the thousands of wind towers that have been built in recent years.

Wind turbines vibrate intensely during operation. This can cause welded tray to become brittle and snap after a relatively short period of time. Cope cold swaged tray has proven durable even in this extreme dynamic state environment. This reliable performance under extreme conditions is the basis for prominent manufacturers incorporating Cope products into their wind tower designs.

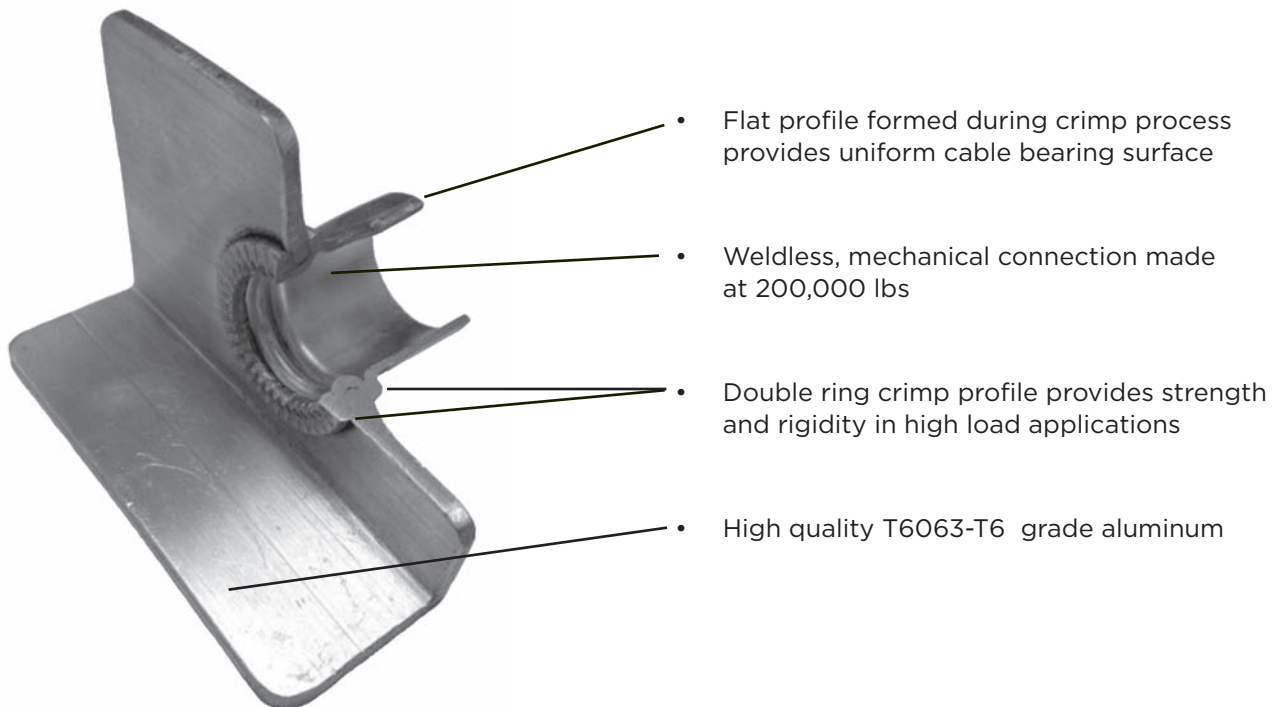

Blank lined area for notes, starting with a thick black header bar.

Blank lined area for notes, starting with a thick black header bar.

Blank lined area for notes, starting with a thick black header bar.

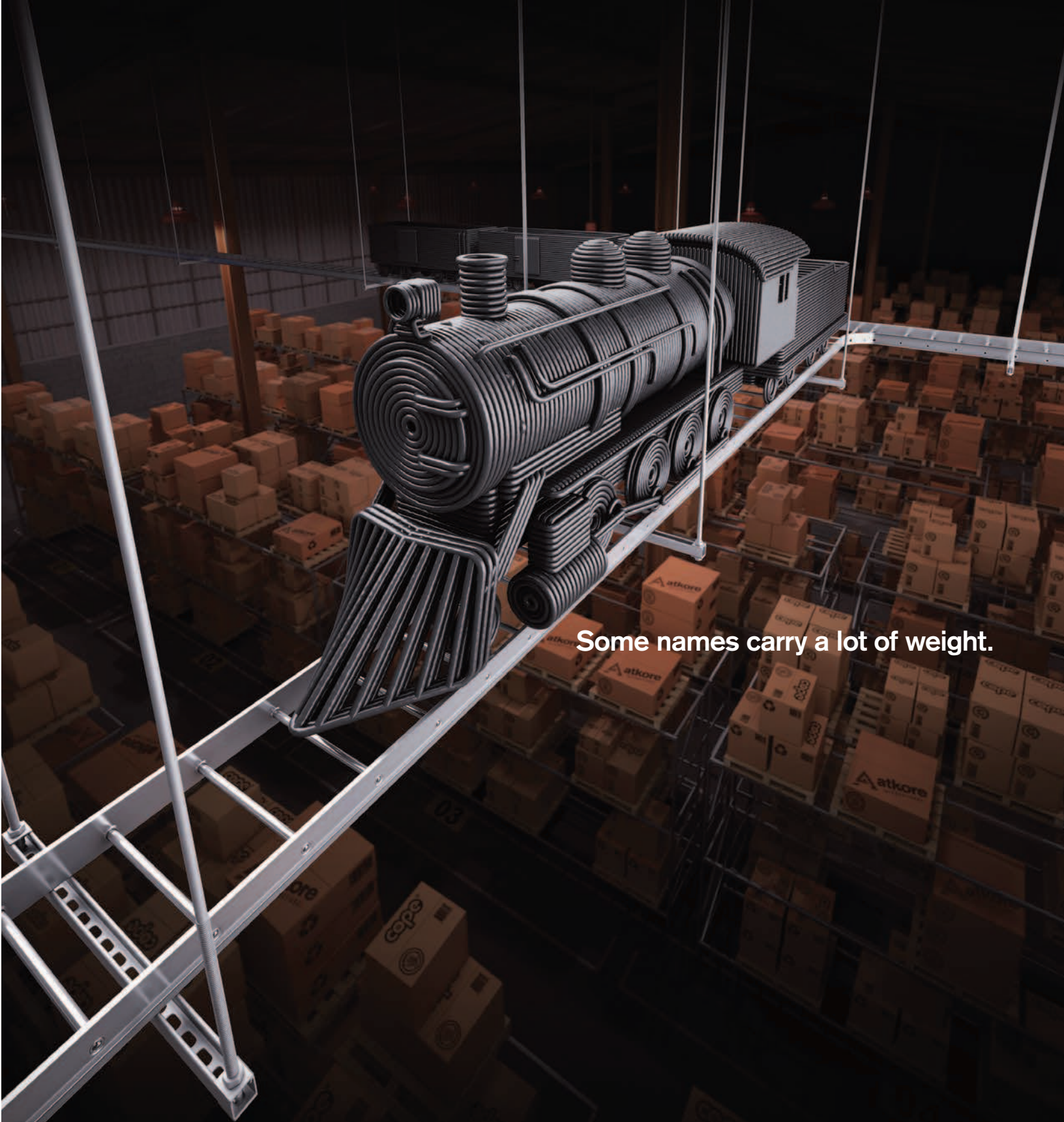

Some names carry a lot of weight.

Cope Ladder Tray with 360° Cold Swage

When it comes to cable management solutions, Cope is the strong choice. And cable trays don't come any stronger than the Cope Ladder Tray. The cold swage connections create the toughest, most rigid cable trays in the industry, so it can handle whatever weight you throw its way. CopeCableTray.com



A PART OF  **atkore**
INTERNATIONAL

Corporate Headquarters:

16100 S. Lathrop Ave.

Harvey, IL 60426

PHONE / 708-339-1610

TOLL FREE / 800-882-5543

www.copecabletray.com

Manufacturing Locations:

11539 North Houston Rosslyn Rd

Houston, Texas 77088

11500 Norcom Road

Philadelphia, PA, 19154



UNISTRUT®



RAZOR RIBBON®

FLEXHEAD INDUSTRIES®



Columbia-MBF™

COPE®

Ridgeline™
Pipe Manufacturing |

UNISTRUT®
Construction



TECTRONTube®



SprinkFLEX®

KAF-TECH®